

(19)



(11)

EP 2 306 453 B1

(12)

EUROPEAN PATENT SPECIFICATION

(45) Date of publication and mention of the grant of the patent:

07.10.2015 Bulletin 2015/41

(51) Int Cl.:

G10L 19/02^(2013.01)

(21) Application number: **09769990.4**

(86) International application number:

PCT/JP2009/060110

(22) Date of filing: **03.06.2009**

(87) International publication number:

WO 2009/157280 (30.12.2009 Gazette 2009/53)

(54) AUDIO SIGNAL COMPRESSION DEVICE, AUDIO SIGNAL COMPRESSION METHOD, AUDIO SIGNAL DECODING DEVICE, AND AUDIO SIGNAL DECODING METHOD

AUDIOSIGNAL-KOMPRIMIERUNGSEINRICHTUNG, AUDIOSIGNAL-KOMPRIMIERUNGSVERFAHREN, AUDIOSIGNAL-DEKODIERUNGSEINRICHTUNG UND AUDIOSIGNAL-DEKODIERUNGSVERFAHREN

DISPOSITIF DE COMPRESSION DE SIGNAL AUDIO, PROCÉDÉ DE COMPRESSION DE SIGNAL AUDIO, DISPOSITIF DE DÉCODAGE DE SIGNAL AUDIO ET PROCÉDÉ DE DÉCODAGE DE SIGNAL AUDIO

(84) Designated Contracting States:

AT BE BG CH CY CZ DE DK EE ES FI FR GB GR HR HU IE IS IT LI LT LU LV MC MK MT NL NO PL PT RO SE SI SK TR

• **MOROOKA Yasuo**

**Hitachi-shi
Ibaraki 316-0011 (JP)**

(30) Priority: **26.06.2008 JP 2008167143**

26.06.2008 JP 2008167144

26.06.2008 JP 2008167145

(74) Representative: **Betten & Resch**

**Patent- und Rechtsanwälte PartGmbB
Theatinerstraße 8
(Fünf Höfe)
80333 München (DE)**

(43) Date of publication of application:

06.04.2011 Bulletin 2011/14

(56) References cited:

JP-A- 2005 057 439 JP-A- 2007 249 009

JP-T- 2001 521 648 US-A1- 2005 165 611

(73) Proprietor: **Japan Science and Technology**

**Agency
Kawaguchi-shi
Saitama 332-0012 (JP)**

• **VELDHUIS R N J ET AL: "Subband coding of digital audio signals without loss of quality", INTERNATIONAL CONFERENCE ACOUSTICS, SPEECH, AND SIGNAL PROCESSING (ICASSP), 23 May 1989 (1989-05-23), pages 2009-2012, XP010082690,**

(72) Inventors:

• **TORAICHI Kazuo**

**Tsukuba-shi
Ibaraki 305-0031 (JP)**

• **NAKAMURA Mitsuteru**

**Tsukuba-shi
Ibaraki 305-0821 (JP)**

• **PILATI LAURENT ET AL: "Enhancements to the SBC CODEC for Voice Communication in Mobile Devices", AES CONVENTION 124; MAY 2008, AES, 60 EAST 42ND STREET, ROOM 2520 NEW YORK 10165-2520, USA, 1 May 2008 (2008-05-01), XP040508563,**

EP 2 306 453 B1

Note: Within nine months of the publication of the mention of the grant of the European patent in the European Patent Bulletin, any person may give notice to the European Patent Office of opposition to that patent, in accordance with the Implementing Regulations. Notice of opposition shall not be deemed to have been filed until the opposition fee has been paid. (Art. 99(1) European Patent Convention).

Description**Technical Field**

5 **[0001]** The present invention relates to an audio signal compression device and an audio signal compression method for efficiently compressing audio signal, as well as an audio signal decoding device (i.e., audio signal demodulation device) and an audio signal decoding method (i.e., an audio signal demodulation method) for decoding the compressed audio signal.

10 **Background Art**

[0002] Conventionally, various encoding methods for compression-coding digital audio signal have been put into practical use. To be specific, when converting an analog audio signal to a digital audio signal, typically a predetermined number of bits of data are sampled every constant sampling period, so that a digital audio signal is generated. Further, 15 a predetermined number of bits of data are compression-coded every constant sampling period by various compression methods suitable for the audio signal.

[0003] For example, there is an art in which a digital audio signal obtained by sampling an analog audio signal within an audible frequency band from 20 Hz to 20 kHz is divided into a predetermined number of bands, and various kinds of arithmetic processing for reducing amount of data, such as discrete cosine transform, are performed on each of the 20 divided bands to encode the signal. Such process has been put into practical use as a compressed audio format such as MP3 (MPEG Audio Layer-3).

[0004]

Patent document 1 discloses an example of this kind of audio signal encoding process.

25 [Patent document 1] International Publication (laid-open) No. 2005/004113 pamphlet

[0005] The document: VELDHUIS R N J ET AL: "Subband coding of digital audio signals without loss of quality", INTERNATIONAL CONFERENCE ACOUSTICS, SPEECH, AND SIGNAL PROCESSING (ICASSP), 23 May 1989 (1989-05-23), pages 2009-2012, XP010082690; relates to subband coding of digital audio signals without loss of quality. 30

Disclosure of the Invention**Problems to be Solved by the Invention**

35 **[0006]** When efficiently compression-coding a digital audio signal, a process of dividing the audio signal into a plurality of bands as described above may be performed. However, a digital filter for extracting signal components of the corresponding audio frequency band is typically used to perform the process of dividing the audio signal into the plurality of bands.

[0007] For example, as shown in FIG. 24, the digital audio signal is divided in the order from low frequency to high frequency: a first band B1, a second band B2, a third band B3,.... At this time, in the case of performing a conventional filter processing, the width of attenuation band of the filter will become large, and there will be a signal-overlapped part between adjacent bands as shown in FIG. 24. In other words, the same signal component will be included both as the highest frequency signal component of the first band B1 and as the lowest frequency signal component of the second band B2. The same goes for the other adjacent bands. If there are such overlapped parts between adjacent bands, 45 when playing the demodulated and synthesized signal, the overlapped signal components will cause degradation of the reproduced sound.

[0008] Further, in the case where the audio signal is compression-coded using a compression method with relatively high compression rate such as MP3, the sound quality after being decoded will deteriorate regardless of the kind of the encoding method. The problem of sound quality deterioration is an unavoidable problem as long as reversibility when performing compression and decoding is not maintained, and the higher the compression rate is, the more seriously the quality of the reproduced sound will deteriorate. This is because if the compression rate is higher, the number of the data to be thinned out will increase when performing encoding process, and therefore the quality of the reproduced sound will deteriorate more seriously. 50

[0009] Particularly, in a conventional compression-coding method, as the band of the audio signal to be encoded, the upper limit frequency on the side of high register range is limited to a certain band, and thereby the amount of data is limited. However, it can be said that limiting the high register signal components will increase the deterioration of the sound quality. 55

[0010] In recent years, as uncompressed digital audio signal (or digital audio signal compressed with a low compression

rate), there is a signal system in which, as high register range, a high frequency range up to dozens to 100 kHz, which is far higher than 20 kHz, is recorded for example. The aforesaid signal system will contribute to improvement of the quality of the reproduced sound if a general reproducing system is used. However, when performing compression-coding on the audio signal with high compression rate such as MP3 as described above, since the aforesaid high register sound is completely removed, the aforesaid a signal system will not contribute to improvement of the quality of the reproduced sound.

[0011] The present invention has been made in view of the above problems, and it is an object of the present invention to substantially reduce deterioration of the sound quality of the decoded signal by performing an efficient encoding process in which high register signal component is maintained, as well as performing a decoding process corresponding to the encoding process.

[0012] Further, it is another object of the present invention to prevent deterioration of sound quality caused by signal overlapping between bands when performing band-dividing and compression-coding on the audio signal.

Means for Solving the Problems

[0013] An audio signal compression device according to the present invention is proposed in independent claim 1.

[0014] Further, as a concrete example of the audio signal decoding device of the present invention, there is an audio signal decoding device according to independent claim 12.

[0015] Further, the present invention includes an audio signal compression method and an audio signal decoding method according to independent claims 9 and 14, respectively.

Advantages of the Invention

[0016] According to the present invention, it is possible to perform efficient compression-coding by function-approximating the signal of each band-divided band and encoding the parameters of the function of each function-approximated band. Further, in such a case, by suitably setting function expression when function-approximating each band, it is possible to perform encoding process in which high register component is maintained, and achieve compression-coding enabling reproduce with sound quality.

Brief Description of Drawings

[0017]

FIG. 1 is a block diagram showing a circuit for performing encoding process used in a first embodiment of the present invention;

FIG. 2A and FIG. 2B each show a waveform of an audio signal used in the first embodiment of the present invention, wherein the audio signal is divided into a low register range, a mid register range, and a high register range;

FIG. 3 is a view showing the structure of a format of a bit-stream used in the first embodiment of the present invention;

FIGS. 4A to 4D are each a graph showing an example of a signal waveform used for explaining the first embodiment of the present invention;

FIG. 5 is a block diagram showing the configuration of a bandpass filter provided in the first embodiment of the present invention;

FIG. 6 is a characteristics chart showing an example of a sampling function used for explaining the first embodiment of the present invention;

FIG. 7 is a characteristics chart showing an example of function approximation used for explaining the first embodiment of the present invention;

FIGS. 8A to 8D are each a graph showing an example of polynomial approximation used for explaining the first embodiment of the present invention;

FIG. 9 is a graph showing time change of a fundamental term and a control term of the sampling function used in the first embodiment of the present invention;

FIG. 10 is a graph showing time change of the sampling function used in the first embodiment of the present invention at the time when a coefficient of the control term is changed;

FIG. 11 is a graph for explaining an example of frequency characteristic of the sampling function used in the first embodiment of the present invention;

FIGS. 12A to 12F explain an example in which function approximation is performed by using the sampling function used in the first embodiment of the present invention;

FIG. 13 is a graph showing a signal array in the case where the function approximation is performed by the sampling function used in the first embodiment of the present invention;

FIG. 14 is a block diagram showing an example of the block configuration for decoding the audio signal encoded using the first embodiment of the present invention;

FIG. 15 is a block diagram showing the configuration of an encoding device used in a second embodiment of the present invention;

5 FIG. 16 is a diagram showing a first modification of a band separation filter used in the second embodiment of the present invention;

FIG. 17 is a diagram showing a second modification of the band separation filter used in the second embodiment of the present invention;

10 FIG. 18 is a diagram showing a third modification of the band separation filter used in the second embodiment of the present invention;

FIG. 19 is a diagram showing a fourth modification of the band separation filter used in the second embodiment of the present invention;

FIG. 20 is a block diagram showing the configuration of an encoding device for dividing the band of an audio signal in unit of "octave" and encoding the signal, according to a third embodiment of the present invention;

15 FIGS. 21A to 21C are each a graph for explaining the relationship between twelve-scale data and octave-band (magnification), for explaining the third embodiment of the present invention;

FIG. 22 is a view showing the relationship between scale frequency range and amplitude (i.e., frequency characteristic), in the case where the band separation filter used in the third embodiment of the present invention is configured so as to be divided into each octave frequency interval.

20 FIG. 23 is a block diagram showing the configuration of a decoding device adapted to decode the signal encoded by the encoding device shown in FIG. 20; and

FIG. 24 is a view for explaining band-dividing according to a prior art.

Best Modes for Carrying Out the Invention

25

<Description of First Embodiment>

[0018] A first embodiment (also referred to as "present embodiment") of the present invention will be described below with reference to FIGS. 1 to 12F.

30 [0019] First, in the first embodiment of the present invention, an audio signal is efficiently compressed and encoded. Further, the encoded audio signal is decoded.

[Description of entire configuration example of encoding device]

35 [0020] First, an example of the entire configuration of an encoding device used in the present embodiment will be described with reference to FIG. 1.

[0021] As shown in FIG. 1, an analog audio signal is outputted from an audio signal source 1. The analog audio signal is supplied to an analog-to-digital converter 2, where a predetermined number of bits is sampled every constant sampling period, so that the analog audio signal is converted into a digital audio signal.

40 [0022] Incidentally, the digital audio signal converted by the analog-to-digital converter 2 is an uncompressed digital audio signal.

[0023] Further, the digital audio signal outputted from the digital-to-analog converter 2 is compression-coded by a filter bank 10 shown in FIG. 1. Incidentally, in the example shown in FIG. 1, the analog audio signal is converted into digital signal; however the present invention also includes a possible configuration in which a digitalized audio signal is prepared to be supplied to a processing system (which is to be described later).

45 [0024] Next, the configuration of the filter bank 10 adapted to perform to compression-coding will be described below. The filter bank 10 is adapted to divide the audio signal into a plurality of bands of signal components.

[0025] To be specific, the filter bank 10 has a plurality of bandpass filters 11a to 11m (m is an arbitrary integral number, and herein m is a number corresponding to a division number), the number of bandpass filters corresponding to the division number, which is a number the frequency band is to be divided into. Each of the bandpass filters 11a to 11m constitutes a basic filter, which is adapted to perform band-dividing with a sampling function $\psi(k)$, for example, as impulse response function, wherein the sampling function $\psi(k)$ is expressed by a section polynomial. Incidentally, the concrete processing examples of extracting the signal of the frequency band assigned to each of the bandpass filters 11a to 11m will be described later.

55 [0026] The signal respectively band-divided by the bandpass filters 11a to 11m are respectively supplied to down-sampling sections 12a to 12m to be subject to a down-sampling process to thin out the sampling number. In each of the down-sampling sections 12a to 12m, a process of thinning out the band-divided signals supplied from the bandpass filters 11a to 11m to a fraction is performed.

[0027] The signal down-sampled by each of the down-sampling sections 12a to 12m is supplied to a function approximation section 20. The function approximation section further includes a plurality of function approximation sections 12a to 21m for each of the divided bands. Further, in each of the function approximation sections 21a to 21m, a function approximation process is performed for each band-divided signal. A parameter used for the function approximation process is outputted. Incidentally, a concrete processing example of the function approximation will be described later with reference to FIGS. 7 to 13.

[0028] The parameters (which are to be described later) obtained by performing function approximation in the respective bands are supplied to a plurality of quantization bit assignment sections 31a to 31m, in which quantization bits are assigned in accordance with the value of each parameter.

[0029] Details of the quantization bit assignment will be described below. Obviously, quantization means a process of converting analog audio signal values to digital signal values. Typically, in the case of an audio (acoustic) signal, real number values (having numbers after the decimal point) of the analog signal is converted to integer values of $\pm 0\sim 65535$ (16 bits).

[0030] In the present invention, function-approximated coefficient values in place of the audio signal values are the real number values corresponding to the analog signal values. In other words, the process of converting the coefficient values to the 16-bit digital values means the "quantization" of the present invention. At this time, in the case where a polynomial approximation is performed on the low register signal shown in FIG. 2A, for example, the coefficient values are approximated by an approximate expression defined by Expression 1.

[Expression 1]

$$y = 2 \times 10^{-5} x^4 - 0.004 x^3 + 0.0227 x^2 + 21.24 x + 318.02$$

[0031] Here, x represents a sampling number. Since sampling frequency is 44.1 kHz, therefore $x = t / (22.7 \mu s)$ if the sampling number is converted to time t. Thus, Expression 1 can be rewritten to Expression 2, which is a function of time t.

[Expression 2]

$$y = (7.53 \times 10^{13}) t^4 - (3.42 \times 10^{11}) t^3 + (4.41 \times 10^7) t^2 + (0.9356 \times 10^6) t + 318.02$$

[0032] Expression 2 represents an approximated polynomial curve of a low register signal shown in FIG. 2B. As is known from Expression 2, the coefficient values of Expression 2 fall within a range of 10^2 (2^8) $\sim 10^{13}$ (2^{40}), which is an extremely wide range. Thus, Expression 2 is transformed to Expression 3 if a scale transformation is performed so that, for example, the coefficient of the fourth degree term and the coefficient of the third degree term become $(10^{-8} / 4(2^{-32}))$ -fold, the coefficient of the second degree term and the coefficient of the first degree term become (2^{-16}) -fold, and the coefficient of the zero degree term become 1-fold.

[Expression 3]

$$y = (17532)_{10} t^4 - (79.6)_{10} t^3 + (672.9)_{10} t^2 + (14.7)_{10} t + (318.02)_{10}$$

[0033] The following can be known from Expression 3:

- Coefficient of fourth degree: $(17532)_{10} = (447C)_H \rightarrow 32\text{-bits shifted}$
- Coefficient of third degree: $(79.6)_{10} = (50)_H \rightarrow 32\text{-bits shifted}$
- Coefficient of second degree: $(672.9)_{10} = (2A1)_H \rightarrow 16\text{-bits shifted}$
- Coefficient of first degree: $(14.7)_{10} = (F)_H \rightarrow 16\text{-bits shifted}$
- Coefficient of zero degree: $(318.02)_{10} = (13E)_H \rightarrow 0\text{-bits shifted (i.e., no shift)}$

[0034] All coefficient values can be expressed by 16-bits values. Incidentally, the inferior number "10" means the number is a decimal number, and the inferior letter "H" means the number is a hexadecimal number.

[0035] As a result, 16-bits is assigned to the coefficient of the fourth degree $(447C)_H$, 8-bits is assigned to the coefficient of the third degree $(50)_H$, 12-bits is assigned to the coefficient of the second degree $(2A1)_H$, 4-bits is assigned to the coefficient of the first degree $(F)_H$, and 12-bits is assigned to the coefficient of the zero degree $(13E)_H$. Such assignment is performed by the quantization bit assignment sections 31a to 31m shown in FIG. 1.

[0036] The signals to which the quantization bits are assigned by the quantization bit assignment sections 31a to 31m are sent to an encoding section 3, where encoding process is performed on the signals of all bands. Further, the encoded data is supplied to a bit-stream forming section 4, from which bit-stream data with a predetermined form is outputted. As described later, the bit-stream forming section 4 forms a bit-stream, to which side information encoded by a side

5

information encoding section 5 is added according to necessity.
[0037] The side information encoded by the side information encoding section 5 includes various kinds of information associated with the encoding process, such as information about the frequency band of each of the divided bands divided by the filter bank 10, information about bit number assigned by the quantization bit assignment sections 31a to 31m, and the like. Here, the information provided from the filter bank 10 to the side information encoding section 5 is a number (a bank number shown in FIG. 3) indicating the band obtained by performing band-separating process, and the information provided from the function approximation section 20 to the side information encoding section 5 is information about functional form and function order. Further, shift amount when performing the aforesaid scale conversion of the coefficient values, bit-width of the coefficient, and coefficient data are provided from the quantization bit assignment sections 31a to 31m. An example of such bit-stream data, to which the side information is added, is shown in FIG. 3.

10

[0038] As shown in FIG. 3, the bit-stream data has a data structure configured by bank number (6-bits), functional form (1-bit), order (3-bits), shift amount (2-bits), bit numbers (2-bits) and coefficient values (0-bit to 16-bits), wherein the bank number shows a band number, the functional form shows whether the approximation is a sampling function approximation or a polynomial function approximation, the order shows the maximum number of times (m-1) by which the sampling function can be differentiated, the shift amount shows whether the shift amount is any one of 0-bit, 8-bits, 16-bits, and 32-bits, and the bit numbers shows whether the bit-width is any one of 0, 1, 2, and 3.

15

20

[0039] Further, an error detection code and an error correction code are generated in the bit-stream forming section 4 according to necessity, and the generated error detection code or error correction code is added to the bit-stream.

[0040] In such manner, the bit-stream data (see FIG. 3) outputted from the bit-stream forming section 4 is either transmitted to the receiving side through various transmission lines, for example, or stored in various storage media. Here, instead if the storage means of the encoding device, an external database may alternatively be used as the storage media for storing the bit-stream data.

25

[Description of waveform example of encoded signal]

[0041] FIGS. 4A to 4D are graphs showing an example of an audio signal processed by the encoding device shown in FIG. 1.

30

[0042] In the graph of each of FIGS. 4A to 4D, the horizontal axis represents time (second) and the vertical axis represents level.

[0043] First, an analog audio signal (i.e., an original signal) shown in FIG. 4A is supplied to the analog-to-digital converter circuit 2. The analog-to-digital converter circuit 2 samples the supplied analog audio signal at a predetermined period, and thereby outputs a sampling signal shown in FIG. 4B. Incidentally, the sampling signal shown in FIG. 4B is plotted by a dotted line having the same waveform as that of the analog audio signal shown in FIG. 4A, which means that the sampling signal shown in FIG. 4B is a collection of sampling points sampled at a very short sampling period.

35

[0044] The sampling signal shown in FIG. 4B is band-separated by the bandpass filters 11a to 11m of the filter bank 10 so as to become frequency-separated signals shown in FIG. 4C. The frequency-separated signals includes signals corresponding to the frequency bands of bandpass filters 11a to 11m, and in the example of FIG. 4C, the signal is separated into three frequency components (i.e., m=3).

40

[0045] The three signals of the respective frequency components shown in FIG. 4C are down-sampled respectively by the down-sampling sections 12a to 12m of the filter bank 10 so as to become sampling values thinned out for each frequency component, as shown in FIG. 4D. Further, the sampling values down-sampled for each frequency component are function-approximated by the function approximation section 20.

45

[Description of example of band-dividing process]

[0046] Next, an example of performing band-dividing process in the bandpass filters 11a to 11m of the filter bank 10 shown in FIG. 1 will be described below.

50

[0047] In the present embodiment, the basic filter is configured with the sampling function $\psi(k)$ as impulse response function, wherein the sampling function $\psi(k)$ is expressed by a section polynomial. Further, the bandpass filters 11a to 11m whose the frequency band is shifted by a predetermined frequency are obtained by performing a known cosine modulation (which is to be described later) on the basic filter, for example. Here, the sampling function $\psi(k)$ expressed by the section polynomial uses a fluency information theory obtained based on the studies by the inventor of the present invention.

55

[0048] FIG. 5 is a block diagram showing a configuration example of the bandpass filters 11a to 11m of the filter bank

10. First, the input audio signal is sequentially delayed by delay elements 81a, 81b, 81c, ..., 81n. For example, in the bandpass filters 11a for extracting the signal of a band 1, the signals at respective delay positions are extracted respectively from the delay elements 81a to 81n, and the extracted signals are respectively supplied to different coefficient multipliers 91a to 91n. Further, the signals of the respective delay positions, which have been multiplied by a coefficient by the coefficient multipliers 91a to 91n, are summed by an adder 92, and the output of the adder 92 is outputted as the signal of the band 1.

[0049] Further, the bandpass filter 11b, which is adapted to extract the signal of a band 2, to the bandpass filter 11m, which is adapted to extract the signal of a band M (in the present example, the signal is divided into M bands), have the same configuration as that of the bandpass filter 11a, and the signals of band 2 to band M are obtained from the respective bandpass filters.

[0050] Here, in a concrete example of the cosine modulation, whole frequency is equally divided into M bands, and in the case where the i-th frequency band is extracted, the coefficient thereof is defined by the following Expression 4.

[Expression 4]

$$f_{ik} = 2 \psi(k) \cos \left\{ \frac{\pi}{M} \left(i + \frac{1}{2} \right) \left(k - \frac{2M-1}{1} \right) \right\} - (-1)^i \left[\frac{\pi}{4} \right]$$

[0051] Here, $\psi(k)$ is the value of the k-th node of a fluency sampling function shown in FIG. 6. In FIG. 6, the horizontal axis represents time (t), and the values of each node and interval between the nodes are defined by the following expression.

[Expression 5]

$$\psi(t) = \begin{cases} -\frac{t^2}{4} - t - 1 & \left(-2 \leq t \leq -\frac{3}{2} \right) \\ \frac{3t^2}{4} + 2t + \frac{5}{4} & \left(-\frac{3}{2} \leq t \leq -1 \right) \\ \frac{5t^2}{4} + 3t + \frac{7}{4} & \left(-1 \leq t \leq -\frac{1}{2} \right) \\ -\frac{7t^2}{4} + 1 & \left(-\frac{1}{2} \leq t \leq \frac{1}{2} \right) \\ \frac{5t^2}{4} - 3t + \frac{7}{4} & \left(\frac{1}{2} \leq t \leq 1 \right) \\ \frac{3t^2}{4} - 2t + \frac{5}{4} & \left(1 \leq t \leq \frac{3}{2} \right) \\ -\frac{t^2}{4} + t - 1 & \left(\frac{3}{2} \leq t \leq 2 \right) \end{cases}$$

[Description of example of function approximation process]

[0052] Next, an example of performing function approximation process with the function approximation section 20 shown in FIG. 1 will be described below with reference to FIGS. 7, 8A, 8B, 8C and 8D.

[0053] In the present embodiment, first, function approximation is performed on the signals having been down-sampled by the down-sampling sections 12a to 12m shown in FIG. 1, and the parameters of the function is used as compression signal values. However, the down-sampling performed herein is not an indispensable process for achieving the audio signal compression method of the present embodiment. Thus, the down-sampling and the function approximation are

not inevitably linked to each other, and the function approximation may also be performed on signals having not been down-sampled. Obviously, since the amount of signal can be reduced to 1/M by down-sampling the original signal to 1/M, it is preferred to perform down-sampling process for purpose of reducing data volume.

5 [0054] Further, in the present embodiment, in the case where a band-divided signal array is function-approximated, an arbitrary section of the band-divided signals is approximated by an n-degree polynomial for each frequency band, for example. Here, the arbitrary section means, when referring to FIG. 4D, an interval between extreme values of the minimum frequency (i.e., an interval equivalent of half period between the maximum value and the minimum value), for example, and in the present embodiment, such section (i.e., the interval between extreme values) is approximated an n-degree polynomial different for each frequency band. Incidentally, if taking an inflection point in place of the maximum value or the minimum value, it is also possible to approximate an interval between the maximum value and the inflection point or an interval between the minimum value and the inflection point by a n-degree polynomial different for each frequency band.

10 [0055] FIG. 7 is a graph showing an example in which approximation by n-degree polynomial is performed for each frequency band. To be specific, FIG. 7 shows an example in which approximation by 2-degree and 3-degree polynomials are performed on the signals of an initial portion (a portion between section 0 and section 0.12) of the down-sampled signals of three bands shown in FIG. 4D. In FIG. 7, the mark "◇" represents the lowest band (the band 1), the mark "□" represents the second-lowest band (the band 2), and the mark "△" represents the third-lowest band (the band 3). Expression 6 is obtained by formulating these graphs.

20

[Expression 6]

$$\text{Band 1: } y = - 256.8x^2 + 73.33x - 0.058$$

25

$$\text{Band 2: } y = - 338.0x^2 + 46.67x - 0.033$$

$$\text{Band 3: } y = - 35.84x^3 - 572x^2 + 19.57x - 0.034$$

30 [0056] Incidentally, such polynomial approximation is expressed by a linear combination expression of fluency sampling functions $\psi^m(t)$ classified by number of times (m-1) at which the function is differentiable, the linear combination expression being defined as Expression 7.

35

[Expression 7]

$$y = a \phi^0(t) + b \phi^1(t) + c \phi^2(t) + d \phi^3(t) + \dots$$

40

[0057] The coefficients a, b, c, d, ... of the polynomial of Expression 7 are coefficient values when the whole bit-stream is expressed as the polynomial, and are generated in the function approximation sections 21a to 21m shown in FIG. 1. Further, as described above, quantization bits are assigned to the data generated in the function approximation sections 21a to 21m by the quantization bit assignment sections 31a to 31m, and encoding process is performed by the encoding section 3. FIGS. 8A to 8D are each a graph showing function approximation between data performed by a single sampling function $\psi^m(t)$.

[0058] To be specific, $\psi^0(t)$ (m=0) shown in FIG. 8A is a constant number, and is an indifferentiable function. In other words, if calculating the number of times (m-1) at which the function is differentiable, the result will be "-1", which is a meaningless number. Actually, the sampling function $\psi^0(t)$ is a rectangular pulse, and each sample value thereof remains unchanged until the next sample value.

[0059] Further, $\psi^1(t)$ (m=1) shown in FIG. 8B is a function whose number of times (m-1) at which the function is differentiable is equals to 0, and as is known from FIG. 8B, the function is indifferentiable at the sample values. To be specific, $\psi^1(t)$ has a triangular waveform, and the function is indifferentiable at the points where two straight lines join together (i.e., at the sample points corresponding to the apexes of the triangular waves). As shown in FIG. 8B, the sampling function $\psi^1(t)$ is a function that straight-line approximates the relationship between the sample values.

[0060] $\psi^2(t)$ (m=2) shown in FIG. 8B is an once-differentiable function wherein (m-1) is equals to 1, and approximates the relationship between the sample values to a quadratic curve. In similar manner, the shape of the curve for interpolating the values between the sample values changes every time when the order is increased, and the value of $\psi^\infty(t)$ is shown

in FIG. 8D. Obviously, interpolated values will become more accurate when the order is increased.

[0061] In such a manner, the function approximation defined as Expression 7 is performed to a predetermined order, the coefficient values a, b, c, d, ... (also referred to as "parameters of compressed signal") of the sampling functions $\psi^m(t)$ are extracted from the function approximation section 20 shown in FIG. 1, and the encoding process is performed by the encoding section as mentioned above.

[0062] Incidentally, other considerable parameters of the compressed signal include the "side information" provided to the side information encoding section 5 in FIG. 1. The data structure of the bit-stream data is shown in FIG. 3, however the bit-stream data does not include the time between extreme value points (for example, the relative time from the start of the audio signal of a song) and sampling point numbers. However, in the case where data having unequal intervals is compressed, the compression can be achieved by adding such side information to the bit-stream data shown in FIG. 3.

[Description of another example of function approximation process]

[0063] Next, an example of performing function approximation different from the function approximation described with reference to FIGS. 6, 7, 8A, 8B, 8C and 8D will be described below with reference to FIGS. 9 to 13. In such a case, only process differs from the function approximation described with reference to FIGS. 6, 7, 8A, 8B, 8C and 8D is the process of the signals supplied to the function approximation sections 20, the signals being divided for each band; and process in other constituent sections is identical.

[0064] A sampling function $\psi_E(t)$, which is obtained by transforming a quadratic sampling function $\psi^2(t)$ is used in this example. Such a sampling function $\psi_E(t)$ is defined by Expression 8.

[Expression 8]

$$\phi_E(t) = f(t) + \alpha \cdot c_0(t)$$

[0065] In Expression 8, $f(t)$ is a fundamental term, and $c_0(t)$ is a control term. FIG. 9 shows the relationship between the fundamental term $f(t)$ and the control term $c_0(t)$. The sampling function defines the value of each of sample points, as a summed signal obtained by summing the waveform of the fundamental term $f(t)$, which is a fundamental waveform, and the waveform of the control term $c_0(t)$ shown in FIG. 9. As shown in FIG. 9, the control term $c_0(t)$ is a function whose level varies up and down, and has a value of "0" at points of $t = 0, \pm 1, \pm 2$.

[0066] Here, the fundamental term $f(t)$ is a finite section polynomial function focused on differentiability, and, for example, is a function can be differentiated only once in the entire range. In other words, the fundamental term $f(t)$ is a function whose function value is a finite value other than zero when a sample position t along the horizontal axis the is in an interval from -1 to +1 (i.e., in an interval $[-1, 1]$), and whose function value is constantly zero when the sample position t is in other intervals. Incidentally, a "finite" function is defined as a function whose function value is a finite value other than zero in the whole or a part of a local interval (excluding the sample position), and whose function value is zero in other intervals.

[0067] To be specific, the fundamental term $f(t)$ is a function that is expressed by an n-degree polynomial function in each of two or more sub-intervals obtained by dividing the interval $[-1, 1]$, and is continuous at the boundary of the sub-intervals (i.e., the value and slope at the boundary are each continuous). The fundamental term $f(t)$ shows a convex-shaped waveform can be differentiated only $(m-1)$ times (m is an integral number equal to or more than 2) in the entire range. Further, the function value becomes "1" only when $t=1$; the function value converges to "0" when $t=\pm 1$; and the function value remains "0" until the sample position goes from " $t=\pm 1$ " to " $t=\pm 2$ ". Incidentally, the fundamental term $f(t)$ may either be a function of a finite impulse response waveform, or be a continuous n-th degree section polynomial function can be differentiated at least once at any position of the sample position interval. For example, as a concrete example, a fundamental sampling function $f(t)$ expressed by a quadratic section polynomial function is defined as Expression 9.

[Expression 9]

$$f(t) = \begin{cases} 0 & \left(-\infty < t \leq -1 \right) \\ 2(t+1)^2 & \left(-1 < t \leq -\frac{1}{2} \right) \\ -2t^2+1 & \left(-\frac{1}{2} \leq t \leq \frac{1}{2} \right) \\ 2(-t+1)^2 & \left(\frac{1}{2} \leq t \leq 1 \right) \\ 0 & \left(1 \leq t < \infty \right) \end{cases}$$

[0068] Next, the control term $c_0(t)$ will be described below. As shown in FIG. 9, the control term $c_0(t)$ is expressed as $c_0(t)=c_r(t)+c_r(-t)$. If being expressed by a quadratic section polynomial, $c_r(t)$ is defined as Expression 10.

[Expression 10]

$$c_r(t) = \begin{cases} 0 & \left(-\infty < t \leq 0 \right) \\ -t^2 & \left(0 \leq t \leq \frac{1}{2} \right) \\ 3(-t+1)^2-2(-t+1) & \left(\frac{1}{2} \leq t \leq 1 \right) \\ -3(t-1)^2+2(t-1) & \left(1 \leq t \leq \frac{3}{2} \right) \\ (-t+2)^2 & \left(\frac{3}{2} \leq t \leq 2 \right) \\ 0 & \left(2 \leq t < \infty \right) \end{cases}$$

[0069] Values between discrete data can be provisionally interpolated by performing superposition based each discrete data, using the control term $c_0(t)=c_r(t)+c_r(-t)$. Thus, it is possible to interpolate the value of any point between the discrete data by linearly summing the provisional interpolated value calculated based on the fundamental term $f(t)$ and the provisional interpolated value calculated based on the control term $c_0(t)$.

[0070] FIG. 10 is a graph showing the change of time characteristic of the sampling function $\psi_E(t)$ at the time when a coefficient α of the control term $c_0(t)$ of the sampling function $\psi_E(t)$ is changed. Thus, by suitably setting the coefficient α of the control term $c_0(t)$, the time characteristic of the finally obtained sampling function can be controlled.

[0071] FIG. 10 shows three examples of: coefficient $\alpha=-1.5$, coefficient $\alpha=-0.25$, and coefficient $\alpha=1.5$. It is known from FIG. 10 that, when changing the coefficient α , the sampling function $\psi_E(t)$ largely changes.

[0072] For example, when changing the variable parameter α in the order of -1.5, -0.25, 1.5, the function value of the sampling function $\psi_E(t)$ will gradually increase in interval of " $-2 \leq t < -1$ " and interval of " $1 \leq t < 2$ ", and the polarity of the waveform will be reversed. While the function value of the sampling function $\psi_E(t)$ will gradually decrease in interval of

"-1≤t≤0" and interval of "0≤t≤1", and the polarity of the waveform will be reversed.

[0073] FIG. 11 shows frequency characteristic of the sampling function $\psi_E(t)$ when the coefficient α the control term $c_0(t)$ is set to different values. In FIG. 11, the horizontal axis represents frequency and the vertical axis represents gain [dB].

[0074] Thus, it is possible to change the characteristics of the sampling function by separately expressing the sampling function $\psi_E(t)$ into the fundamental term $f(t)$ and the control term $c_0(t)$ and adjusting the coefficient α of the control term $c_0(t)$.

[0075] FIG. 11 shows the frequency characteristic of the sampling function $\psi_E(t)$ when playing music recorded in a CD, for example. As can be known from FIG. 11 that the frequency characteristic of the sampling function $\psi_E(t)$ is: when $\alpha=-0.25$, the characteristic (which represents a reference) is characterized that the gain gently decreases until frequency reaches 44.1 kHz, which is the sampling frequency of CD; and when α is changed to 1.5 or -1.5, the gain increases in high-frequency area, and a flat frequency characteristic is obtained in the whole frequency area. Further, in low-frequency area, the gain decreases when $\alpha=1.5$ but increases when $\alpha=-1.5$, compared with the case where $\alpha=-0.25$. This is a usable characteristic in the case where the low register range of music is wanted to be focused or emphasized. Thus, it is possible to obtain a characteristic so that the gain increases in high-frequency area, and a flat frequency characteristic is obtained in the whole frequency area by changing the value of α , and it is also possible to adjust the increase or decrease of the gain (i.e., to make low register prominent, or to make high register prominent) in the low register range so as to obtain a characteristic suited to the taste of the user.

[0076] FIGS. 12A to 12B explain a method for interpolating values in an arbitrary signal interval, such as an interval between extreme values (i.e., an interval between sample values x_1 and x_2 (between time t_1 and t_2)) for example, using four sampling functions $\psi_E(t)$ (having four coefficient values of $\alpha_0 \sim \alpha_3$) each having a coefficient value α of control term $c_0(t)$ different for each sample value. Thus, the waveforms in the interval between sample values x_1 and x_2 (between time t_1 and t_2) are function-approximated respectively by the four sampling functions, and the results are summed, and the summed value represents an approximated waveform of the original audio signal.

[0077] To be specific, as shown in FIG. 12A, sample values $x_0, x_1, x_2, x_3, x_4, x_5$ are respectively obtained at times $t_0, t_1, t_2, t_3, t_4, t_5$. Here, it is exhibited that the signal waveform between time t_1 and time t_2 is almost exactly approximated. In the example of FIGS. 12A to 12F, the coefficient of the control term $c_0(t)$ of the sampling function $\psi_E(t)$ at time t_0 is α_0 , the coefficient of the control term $c_0(t)$ at time t_1 is α_1 , the coefficient of the control term $c_0(t)$ at time t_2 is α_2 , and the coefficient of the control term $c_0(t)$ at time t_3 is α_3 .

[0078] At this time, the signal waveform in the interval between time t_1 and time t_2 is obtained by summing the waveforms of the four signals in the interval between time t_1 and time t_2 . The signal waveform in the interval between other two sample points is also obtained by summing the waveforms of the four corresponding sampling functions $\psi_E(t)$.

[0079] The summed signal can be defined as Expression 11.

[Expression 11]

$$y(t) = \phi_E(t-t_0)x_0 + \phi_E(t-t_1)x_1 + \phi_E(t-t_2)x_2 + \phi_E(t-t_3)x_3$$

[0080] Thus, the signal $y(t)$ between sample values (i.e., in the interval) can be exactly exhibited by summing the sampling functions $\psi_E(t)$, and it is possible to obtain a well compressed signal.

[0081] Here, the coefficient α of the control term $c_0(t)$ of each of the sampling functions $\psi_E(t)$ needs to be selected to a suitable value; however, since it is difficult to calculate a correct coefficient α at the head portion of the audio signal inputted in real time, a fixed value α_0 can be considered as the coefficient α at the head portion.

[0082] FIG. 13 is a graph showing an inputted typical digital signal array. As shown in FIG. 13, in the aforesaid signal array, the extreme values, which are indicated by heavy lines, exist at $t=[0, 0.06, 0.16, 0.26, 0.34, 0.44]$.

[0083] Initialization is performed so that at start time (i.e., $t=0$) of the signal array, the coefficient α is the fixed value α_0 (for example, $\alpha_0=-0.25$, which corresponds to a sampling function most suitable for playing signal having an equal interval).

[0084] Here, in the case of $\psi_E(t-\tau)$ obtained by shifting the sampling function $\psi_E(t)$ defined by Expression 8 by time τ , the value of the sampling function is equal to the value of $\psi_E(0)$ when $t = \tau$, and it is possible to perform a convolution operation with the sample values. The convolution operation will be described below. The case considered here is one in which input signal values $y_a(t)$ in the time interval $[\tau_k, \tau_{k+1}]$ are interpolated using the sampling function $\psi_E(t)$. At this time, based on the fluency theory proposed by the inventor of the present invention, the input signal is approximated according to Expression 12 by using four sample values, which are two sample values $y_a(\tau_k), y_a(\tau_{k+1})$ at ends of the interval, and two sample values $y_a(\tau_{k-1}), y_a(\tau_{k+2})$ before and after the interval.

[Expression 12]

$$y_a(t) = \psi_E(t - \tau_{k-1})y_a(\tau_{k-1}) + \psi_E(t - \tau_k)y_a(\tau_k) + \psi_E(t - \tau_{k+1})y_a(\tau_{k+1}) + \psi_E(t - \tau_{k+2})y_a(\tau_{k+2})$$

[0085] In Expression 12, since the influence of the fourth term $\psi_E(t - \tau_{k+2})y_a(\tau_{k+2})$ on the signal $y_a(t)$ in the interval $[\tau_k, \tau_{k+1}]$ is small, the fourth term $\psi_E(t - \tau_{k+2})y_a(\tau_{k+2})$ is omitted, so that an approximate expression possible to be successively calculated can be obtained as Expression 13.

[Expression 13]

$$y_a(t) \approx \psi_E(t - \tau_{k-1})y_a(\tau_{k-1}) + \psi_E(t - \tau_k)y_a(\tau_k) + \psi_E(t - \tau_{k+1})y_a(\tau_{k+1})$$

[0086] In Expression 13, unknown sampling function (wherein α is unknown) is in $\psi_E(t - \tau_{k+1})$ of the third term. In other words, this thinking is to perform approximation with the value of Expression 13 to identify the input signal in the interval $[\tau_{k+1}]$.

[0087] If $\psi_E(t - \tau_{k-1})$ and $\psi_E(t - \tau_k)$ are previously obtained, Expression 14 can be obtained based on Expression 13. To be specific, if actual sample value at time t is $y_a(t)$, Expression 13 can be transformed into Expression 14 using an actual sample value $y_a(\tau_{k-1})$ when " $t = \tau_{k-1}$ " and a sample value $y_a(\tau_{k-1})$ when " $t = \tau_{k-1}$ " and a sample value $y_a(\tau_k)$ when " $t = \tau_k$ ". $\Delta y(t)$ in Expression 14 is $\psi_E(t - \tau_{k+1})y_a(\tau_{k+1})$, which is what to be obtained here.

[Expression 14]

$$\Delta y(t) = y_a(t) - (\psi_E(t - \tau_{k-1})y_a(\tau_{k-1}) + \psi_E(t - \tau_k)y_a(\tau_k)) \approx \psi_E(t - \tau_{k+1})y_a(\tau_{k+1})$$

[0088] Here, sampling function $\psi_E(t - \tau_{k+1}) = f(t - \tau_{k+1}) + \alpha_{k+1}c(t - \tau_{k+1})$ is obtained (wherein α_{k+1} is an unknown) by using Expression 8, so that Expression 15 can be obtained.

[Expression 15]

$$\Delta y(t) \approx \psi_E(t - \tau_{k+1})y_a(\tau_{k+1}) = \{f(t - \tau_{k+1}) + \alpha_{k+1}c(t - \tau_{k+1})\}y_a(\tau_{k+1})$$

[0089] In Expression 15, since $f(t - \tau_{k+1})$ is the fundamental term component and is a known function, if the control term component, which is a value subtracted from $\Delta y(t)$, is expressed as $\Delta x(t)$, then $\Delta x(t)$ can be defined by Expression 16.

[Expression 16]

$$\Delta x(t) = \Delta y(t) - f(t - \tau_{k+1})y_a(\tau_{k+1}) \approx \alpha_{k+1}c(t - \tau_{k+1})y_a(\tau_{k+1})$$

[0090] If approximation error of Expression 16 is expressed as $\varepsilon(t)$, the following Expression 17 can be obtained.

[Expression 17]

$$\varepsilon(t) = \Delta x(t) - \alpha_{k+1}c(t - \tau_{k+1})y_a(\tau_{k+1})$$

[0091] From Expression 17, approximation error $\varepsilon(t)$ in the interval $[\tau_k, \tau_{k+1}]$ is obtained with respect to all input points, the approximation error $\varepsilon(t)$ is created for n points (preferably for all points) in the interval $[\tau_k, \tau_{k+1}]$, and E , which represents the sum of n -pieces of square of $\varepsilon(t_i)$, is obtained by Expression 18.

[Expression 18]

5

$$E = \sum_{i=1}^n \varepsilon^2(t_i)$$

[0092] The α_{k+1} which makes E minimum is the α_{k+1} to a curve of the minimum square error approximation. In other words, the α_{k+1} that makes E minimum is obtained when Expression 19 is true, and can be obtained by Expression 20.

10

[Expression 19]

$$\frac{\partial E}{\partial \alpha_{k+1}} = 0$$

15

[Expression 20]

20

$$\alpha_{k+1} = \frac{\sum_{i=1}^n \{c(t_i - \tau_{k+1}) y_a(\tau_{k+1}) \Delta x(t_i)\}}{\sum_{i=1}^n \{c(t_i - \tau_{k+1}) y_a(\tau_{k+1})\}^2}$$

25

herein:

$$\Delta x(t_i) = \Delta y(t_i) - f(t_i - \tau_{k+1}) y_a(\tau_{k+1})$$

30

$$\Delta y(t_i) = y_a(t_i) - (\phi_E(t_i - \tau_{k-1}) y_a(\tau_{k-1}) + \phi_E(t_i - \tau_k) y_a(\tau_k))$$

[0093] If α_{k+1} , which is the coefficient of the control term, has been determined based on the above Expression 20, the signal in the interval $[\tau_k, \tau_{k+1}]$ can be played with minimum approximation error when $t = \tau_{k+1}$ by using Expression 21.

[Expression 21]

35

$$y(t) = \phi_E(t - \tau_{k-1}) y_a(\tau_{k-1}) + \phi_E(t - \tau_k) y_a(\tau_k) + \phi_E(t - \tau_{k+1}) y_a(\tau_{k+1})$$

[0094] Next, the sample value $y_a(t)$ in the interval $[\tau_k, \tau_{k+1}]$ is calculated when the interval $[\tau_k, \tau_{k+1}]$ is $[0, 0.06]$ (an interval between the sample point at $t=0$ and the sample point at $t=0.06$ shown in FIG. 13, i.e., when $\tau_k=0$, and $\tau_{k+1}=0.06$).

[0095] Incidentally, in the case where calculation is performed in the interval $[0, 0.06]$, since τ_{k-1} does not exist, it is supposed that $y_a(\tau_{k-1})=0$. Here, in Expression 20, calculation is performed at three points $i=1, 2, 3$.

[0096] If input signal $y_a(0)$ at the time when $t=0$ is substituted in $\Delta y(t_i)$ of Expression 20, $\Delta y(t_i)$ becomes a value obtained by subtracting " $(f(t_i) + \alpha_0 * c_0(t_i)) * y_a(0)$ " from input signal $y_a(t_i)$.

[0097] On the other hand, since $\tau_{k+1}=0.06$, $\Delta x(t)$ (which is the control term) is calculated below based on Expression 16:

40

$$\Delta x(t) = \Delta y(t) - f(t-0.06) * y_a(0.06)$$

[0098] $\Delta y(t)$ is calculated below based on Expression 15:

$$\Delta y(t) = \{f(t - 0.06) + \alpha_1 c_0(t - 0.06)\} * y_a(0.06)$$

[0099] The below expression can be obtained by substituting $\Delta y(t)$ in the expression of $\Delta x(t)$:

$$\Delta x(t) = \Delta y(t) - f(t - 0.06) * y_a(0.06) = \alpha_1 * c_0(t - 0.06) * y_a(0.06)$$

[0100] An equation of α_1 by which the sum of squares of the error function $\varepsilon(t)$ becomes the minimum can be created by applying the above relationship to " $t=t_i$ ($i=1, 2, 3$)". Here, the only unknown is α_1 , therefore α_1 can be obtained from Expression 20.

[0101] Similarly, when data at " $t=0.16$ " is inputted, the next coefficient α_2 can be determined based on the data in the interval $[0.06, 0.06]$, so that the coefficient α_i can be sequentially obtained. If the coefficient α_i is obtained, the data in the corresponding time interval become function-approximated.

[0102] Generally, when a sampling function $\Psi(t)$ having an unknown parameter with variable characteristics ($\psi(t)=\psi_E(t)$) in the present invention) is provided, it is possible to provide Expression 22 (as an approximate expression) with respect to the input signal $y_a(t)$ (in which time t is in the interval $[\tau_k, \tau_{k+1}]$) to identify the unknown parameter of $\Psi(t-\tau_{k+1})$ so that Expression 22 is approximated with the minimum square error.

[Expression 22]

$$y_s(t) \approx \Psi(t - \tau_{k-1}) y_a(\tau_{k-1}) + \Psi(t - \tau_k) y_a(\tau_k) + \Psi(t - \tau_{k+1}) y_a(\tau_{k+1})$$

[0103] In the case where the sampling function is expressed as " $\Psi(t)=f(t)+\alpha c(t)$ ", such as the case of the present invention, the unknown parameter α is identified based on Expression 23. Expression 23 is an equivalence of Expression 20.

[Expression 23]

$$\alpha_{k+1} = \frac{\sum_{i=1}^n \{c(t_i - \tau_{k+1}) y_a(\tau_{k+1}) \Delta x(t_i)\}}{\sum_{i=1}^n \{c(t_i - \tau_{k+1}) y_a(\tau_{k+1})\}^2}$$

herein:

$$\Delta x(t_i) = \Delta y(t_i) - f(t_i - \tau_{k+1}) y_a(\tau_{k+1})$$

$$\Delta y(t_i) = y_s(t_i) (\Psi(t_i - \tau_{k-1}) y_a(\tau_{k-1}) + \Psi(t_i - \tau_k) y_a(\tau_k))$$

$$\Psi(t - \tau_k) = f(t - \tau_k) + \alpha_k c(t - \tau_k)$$

[0104] Thus, as compressed data, it is possible to treat $[y_a(k), \alpha_k, \tau_k]$ as data of one interval, so that number of data can be reduce to far less than the number of the original sample data.

[0105] Further, when playing the signal encoded in such a manner, function interpolation when time t is in the interval $[\tau_k, \tau_{k+1}]$ can be performed based on Expression 24 by performing function arithmetic from the compressed data of $[y_a(k), \alpha_k, \tau_k]$.

[Expression 24]

$$y(t) = \phi_E(t - \tau_{k-1})y_a(\tau_{k-1}) + \phi_E(t - \tau_k)y_a(\tau_k) + \phi_E(t - \tau_{k+1})y_a(\tau_{k+1})$$

$$\phi_E(t - \tau_k) = f(t - \tau_k) + \alpha_k c(t - \tau_k)$$

[0106] In other words, the signal $y(t)$ is approximated with respect to the original signal $y_a(t)$ with the minimum square error, and can be outputted as an accurately reconstructed and interpolated reproduced signal.

[Description of block diagram for performing decoding process]

[0107] FIG. 14 is a block diagram showing the configuration of a decoding device for the signal processed and encoded by the encoding device shown in FIG. 1.

[0108] As shown in FIG. 14, the bit-stream encoded by the bit-stream forming section 4 shown in FIG. 1 is supplied to a bit-stream input section 51 where an error detection process or error correction process is performed using the error detection code or error correction code added to the bit-stream.

[0109] Further, from the inputted bit-stream, the encoded data of the compressed parameters of the function (i.e., the coefficient values a, b, c, d, \dots , of the sampling functions $\psi^m(t)$) is supplied to a decoding section 52 where the parameter is decoded for each band. When decoding the parameter, side information from a side information decoding section 55 is referenced. The side information is the information provided from the filter bank to the side information encoding section 5 as described above. To be specific, the side information includes information about the number indicating the band obtained by performing band-separating process (i.e., the bank number shown in FIG. 3), information about the form and order of the function from the function approximation section 20, and the like. The side information is separated by the bit-stream input section 51, and supplied to the side information decoding section 55 so as to be decoded.

[0110] The parameter of each of the bands decoded by the decoding section 52 is supplied to the inverse quantization sections 53a to 52m where inverse quantization is performed. Further, each parameter having been subjected to the inverse quantization by the inverse quantization sections 53a to 53m is supplied to function interpolation sections 54a to 54m, by which the values of the sample points of each band are reconstructed. Here, the process performed by the function interpolation sections 54a to 54m is a process inverse to the approximation process performed by the function approximation sections 21a to 21m on the side of the encoding device shown in FIG. 1.

[0111] Further, the output of each of the function interpolation section 54a to 54m is supplied to up-sampling sections 61a to 61m of a filter bank 60, where a process inverse to the process performed by the down-sampling sections 12a to 12m on the side of the encoding device shown in FIG. 1 is preformed. The up-sampled output of each band is supplied to a sub-band synthesis filter 62 to be synthesized to a digital audio signal of one system. Further, the obtained digital audio signal is supplied to a digital-to-analog converter 56, and the analog audio signal converted by the digital-to-analog converter 56 is outputted to an output terminal 57.

[0112] Thus, by performing the decoding process, which is a process inverse to the encoding process, the original audio signal can be well reconstructed.

[Description of second embodiment]

[0113] A second embodiment of the present invention will be described below with reference to FIG. 15. The second embodiment shown in FIG. 15 and the first embodiment shown in FIG. 1 are identical to each other except for the filter bank 10. Since the other components (i.e., the function approximation section 20, the quantization bit assignment sections 31a to 31m, the encoding section 3, the bit-stream forming section 4, and the side information encoding section 5) in the second embodiment are identical to those of the first embodiment, these components are denoted by the same reference numerals as of the first embodiment and the explanation thereof will be omitted.

[0114] First, an example of entire configuration of an encoding device of the second embodiment of the present invention will be described below with reference to FIG. 15. As shown in FIG. 15, an analog audio signal is supplied from an audio signal source 1 to an analog-to-digital converter 2 in the same manner as the first embodiment. The digital audio signal outputted from the digital-to-analog converter 2 is supplied to a filter bank 10. The filter bank 10 is adapted to divide the digital audio signal into signal components of a plurality of bands in different manner from the first embodiment shown in FIG. 1.

[0115] Similar to FIG. 1, the filter bank 10 shown in FIG. 15 (the second embodiment) also has a plurality of bandpass filters 11a to 11m (m is an arbitrary integral number, and herein m is a number corresponding to division number), the number of bandpass filters corresponding to the division number by which the frequency band is divided. Further, each of the bandpass filters 11a to 11m constitutes a basic filter to perform band-dividing with a sampling function $\psi(k)$, for example, as impulse response function, wherein the sampling function $\psi(k)$ is expressed by a section polynomial.

[0116] First, in the second embodiment, the signal of a first frequency band is separated by the bandpass filter 11a. Further, the signal separated by the bandpass filter 11a and the original audio signal supplied from the analog-to-digital converter 2 are supplied to a subtracter 13a, where the signal separated by the bandpass filter 11a is subtracted from the original audio signal. Further, the signal from the subtracter 13a is sent to the bandpass filter 11b, where the signal of a second frequency band is separated.

[0117] In the same manner, the output of each of the bandpass filters 11b, 11c, ... is supplied to a corresponding one of a plurality of subtracters 13b, 13c, ... arranged before the bandpass filter of the next band so as to be subtracted from the digital audio signal supplied from the analog-to-digital converter 2, and the subtracted signal is sent to the bandpass filter. Note that, the aforesaid connection of the subtracters is just one example, and the present invention includes other configurations for performing the subtraction process such as the configurations shown in FIGS. 16 to 19, which are to be described later.

[0118] The signals band-divided by the bandpass filters 11a to 11m are respectively supplied to down-sampling sections 12a to 12m, which are provided individually for the signal of each band, where a down-sampling process is performed in which sampling number is thinned out to, for example, a fraction.

[0119] The signal down-sampled by each of the down-sampling sections 12a to 12m is supplied to a function approximation section 20 where function approximation process is performed for each divided band by function approximation sections 21a to 21m as is described with reference to FIG. 1. The following operations are identical to those having been described with reference to FIG. 1, and therefore will not be repeated here.

[0120] Next, a first modification of a band separation filter used in the second embodiment of the present invention will be described below with reference to FIG. 16.

[0121] As shown in FIG. 16, the digital audio signal outputted by the analog-to-digital converter 2 shown in FIG. 1 or a digital audio signal inputted from the outside is inputted to a terminal 10a.

[0122] The digital audio signal inputted to the terminal 10a is supplied to a first band separation filter 11a, where the signal component of a first band is extracted. The signal of the first band is down-sampled by a down-sampling section 12a. Further, the down-sampled signal of the first band is supplied to a function approximation section 21a of the function approximation section 20 to be function-approximated.

[0123] Further, the digital audio signal of the first band outputted by the first band separation filter 11a is supplied to a subtracter 13a. The subtracter 13a subtracts the digital audio signal outputted by the first band separation filter 11a from the digital audio signal inputted to the terminal 10a, and the result is supplied to a second band separation filter 11b. Further, the signal component of the second band extracted in the second band separation filter 11b is down-sampled by a down-sampling section 12b and then supplied to a function approximation section 21b to be function-approximated.

[0124] Similarly, the difference signal from the subtracter and the digital audio signal of the second band outputted from the second band separation filter 11b are supplied to a subtracter 13b, and a signal obtained by subtracting the signal of the second band outputted from the second band separation filter 11b from the output of the subtracter 13a is outputted from the subtracter 13b. Further, the output from the subtracter 13b is down-sampled by a down-sampling section 12c and then function-approximated as the signal of a third band by a function approximation section 21c.

[0125] When being band-divided and function-approximated with a circuit configuration shown in FIG. 16, as the band-divided signal, no overlapped part of signal components will be caused in the end portions of each frequency band, and therefore better band-dividing can be performed. To be specific, when extracting the signal component of the second band with the amount of data 11b, since the signal component of the first band has been moved by the subtracter 13a arranged before the second band separation filter 11b, the signal component of the first band will not be added, and therefore the overlapping of the signal component of the first band can be effectively removed. The overlapping of signal component of the signal components of the second band and third band can also be removed in the same manner.

[0126] Next, a second modification of the band separation filter used in the second embodiment of the present invention will be described below with reference to FIG. 17.

[0127] As shown in FIG. 17, the digital audio signal obtained in an input terminal 10a is supplied to a first band separation filter 11a, where the signal component of a first band (the low register signal component) is extracted. The signal of the first band is down-sampled by a down-sampling section 12a, and then the down-sampled signal of the first band is function-approximated by a function approximation section 21a.

[0128] Further, the digital audio signal obtained in the terminal 10a is supplied to a third band separation filter 11c, where the signal component of a third band (the high register signal component) is extracted. The signal of the third band is down-sampled by a down-sampling section 12c, and then the down-sampled signal of the third band is supplied to a function approximation section 21c to be function-approximated.

[0129] The characteristic of the second modification shown in FIG. 17 lies in the method for extracting the signal of the second band. To be specific, the digital audio signal of the low register range of the first band outputted by the first band separation filter 11a and the digital audio signal of the high register range of the third band outputted by the third band separation filter 11c are summed by an adder 14a. Further, the summed output of the adder 14a is supplied to a

subtractor 14b to be subtracted from the inputted digital audio signal.

[0130] Since the signal of the first band (i.e., the low register signal) and the signal of the third band (i.e., the high register signal) are subtracted from the digital audio signal obtained in the terminal 10a by performing the aforesaid subtraction process with the subtracter 14b, only the signal component of the second band (i.e., the mid register signal) is extracted from the subtracter 14b.

[0131] Further, the signal of the second band (i.e., the output of the subtracter 14b) is down-sampled by a down-sampling section 12b and then supplied to a function approximation section 21b to be function-approximated.

[0132] When being band-divided and function-approximated with a configuration shown in FIG. 17, as the band-divided signals, no overlapped part of signal components will be caused in the end portions of each frequency band, and therefore good band-dividing can be performed.

[0133] Next, a third modification of the band separation filter used in the second embodiment of the present invention will be described below with reference to FIG. 18.

[0134] As shown in FIG. 18, the digital audio signal inputted from a terminal 10a is supplied to a first band separation filter 11a, where the signal component of a first band is extracted. Further, the signal of the first band is down-sampled by a down-sampling section 12a and then function-approximated by a function approximation section 21a.

[0135] The digital audio signal having been function-approximated by the function approximation section 21a is supplied to a function interpolation section 22a to be reconstructed into the original digital audio signal, and further, the sampling period of the signal is returned to the original sampling period by an up-sampling section 24a. Further, the signal having been returned to the original sampling period is supplied to a subtracter 15a.

[0136] In the subtracter 15a, the digital audio signal outputted by the up-sampling section 24a is subtracted from the digital audio signal provided from the terminal 10a. Further, the output of the subtracter 15a is supplied to a second band separation filter 11b, where the signal component of a second band is extracted. The signal of the second band is down-sampled by a down-sampling section 12b and then function-approximated by a function approximation section 21b.

[0137] Similarly, the output of the function approximation section 21b is reconstructed as the original digital audio signal by a function interpolation section 22b, and further, the reconstructed signal is returned to the original sampling period by an up-sampling section 24b. Further, the signal having been returned to the original sampling period is supplied to a subtracter 15b.

[0138] The digital audio signal up-sampled by the up-sampling section 24b is subtracted from the digital audio signal from the subtracter 15a by the subtracter 15b, and the signal component of the third band is extracted from the output of the subtracter 15b. Further, the signal of the third band is down-sampled by a down-sampling section 12c and then function-approximated by a function approximation section 21c.

[0139] When subtracting the signal function-approximated with the circuit configuration shown in FIG. 18 from the original signal, no overlapped part of signal components will be caused in the end portions of each frequency band, and therefore good band-divided signals can be obtained.

[0140] Next, a fourth modification of the band separation filter used in the second embodiment of the present invention will be described below with reference to FIG. 19.

[0141] As shown in FIG. 19, the digital audio signal provided from the terminal 10a is supplied to a first band separation filter 11a, where the signal component of a first band (the low register signal component) is extracted. The signal of the first band is sent to a down-sampling section 12a to be down-sampled, and then function-approximated by a function approximation section 21a.

[0142] Similarly, the digital audio signal provided from the terminal 10a is supplied to a second band separation filter 11b, where the signal component of a second band (the mid register signal component) is extracted. Further, the signal of the second band is down-sampled by a down-sampling section 12b and then function-approximated by a function approximation section 21b.

[0143] The characteristic of the fourth modification shown in FIG. 19 lies in the method for extracting the signal of the third band. To be specific, the function approximation value of the first band obtained from the function approximation section 21a and the function approximation value of the second band obtained from the function approximation section 21b are respectively reconstructed by a function interpolation section 22a and a function interpolation section 22b, and then the reconstructed signals of the two bands are summed by an adder 16. Further, the output of the adder 16 is up-sampled by an up-sampling section 17 and then supplied to a subtracter 18.

[0144] Further, in the subtracter 18, the output of the up-sampling section 17 is subtracted from the digital audio signal obtained in the terminal 10a. By performing the subtraction, the signal of the first band (i.e., the low register signal) and the signal of the second band (i.e., the mid register signal) are subtracted from the digital audio signal obtained from the terminal 10a, and as a result, only the signal component of the third band (i.e., the high register signal) is extracted from the subtracter 18.

[0145] Further, the signal of the third band obtained from the subtracter 18 is down-sampled by a down-sampling section 12c and then function-approximated by a function approximation section 21c.

[0146] When function-approximating the signals band-divided by the band-dividing method shown in FIG. 19, as the

band-divided signals, no overlapped part of signal components will be caused in the end portions of each frequency band, and therefore good band-divided signals can be obtained.

[0147] Incidentally, each of the modifications shown in FIGS. 16 to 19 is explained using an example in which the signal is divided into three bands; however each of the modifications may also be applied to a case where the signal is divided into more bands. In other words, the circuit can be configured so that the signal is divided into four or more bands. Further, the down-sampling section and the up-sampling section are indicated by a broken line in each of the modifications shown in FIGS. 16 to 19, this means that the down-sampling section and the up-sampling section are not indispensable constituent elements of the present invention.

[0148] To be specific, the aforesaid embodiments are explained based on a method in which the input signal having been down-sampled is function-approximated and compressed, and up-sampled after function reproduce. However, since the function approximation indicates the interval between extreme values by function, the function approximation itself has down-sampling function, and, since the signal in the interval between extreme values is played by function arithmetic while playing signal, the function approximation itself has up-sampling function. Thus, in the present invention, the down-sampling process and the up-sampling process are not indispensable.

[Description of third embodiment]

[0149] Next, as a third embodiment of the present invention, an example of dividing the band of an audio signal in unit of "octave" will be described below.

[0150] FIG. 20 is a block diagram showing entire configuration of a circuit device for dividing the band of an audio signal in unit of "octave". The third embodiment is also similar to the first and second embodiments in many respects; however since the signal is proceeded in unit of "octave" in the third embodiment, the components in FIG. 20 are denoted by different reference numerals from those of FIGS. 1 and 15.

[0151] As shown in FIG. FIG. 20, an analog audio signal outputted from an audio signal source 101 is supplied to an analog-to-digital converter 102, where the signal is converted to a digital audio signal by sampling a predetermined number of bits every constant sampling period. The digital audio signal converted by the analog-to-digital converter 102 is an uncompressed digital audio signal.

[0152] A configuration for compression-coding the digital audio signal outputted from the digital-to-analog converter 102 and the operation thereof will be described below.

[0153] First, the digital audio signal outputted from the digital-to-analog converter 102 is supplied to octave-band separation filters 110a to 110n (n is an integral number corresponding to octave number). The octave-band separation filters 110a to 110n are filters adapted to separate the inputted audio signal into signal components of a plurality of different octave-bands. Here, the octave-band means "frequency band of one octave", wherein one octave is referred to as "octave interval" in the western music. If an audio signal with frequency up to 40 kHz, which is twice as broad as the audible band, is divided into each one octave, the audio signal will be separated into about a dozen octave-bands.

[0154] The octave-band separation filters 110a to 110n are, for example, each a basic filter with a sampling function $\psi(k)$ as impulse response function, wherein the sampling function $\psi(k)$ is expressed by a section polynomial.

[0155] The signals band-divided by the octave-band separation filters 110a to 110n are respectively supplied to scale-band separation filters 121a-1211, 122a-1221, ... 129a-1291, which each separate one octave-band into twelve scales compliant frequency bands.

[0156] The twelve scales mentioned here is defined to express an octave interval in a manner in which semitones are included. However, when referring to an octave interval constituting one octave, the tone one octave higher from the fundamental tone is included; while when referring to twelve scales, the tone one octave higher from the fundamental tone is not included. In the description below, when referring to one octave-band, it means a band including twelve scales, and the band of the scale of the tone one octave higher is not included.

[0157] The output of the first octave-band separation filter 110a, which obviously is an audio signal having a frequency width of one octave, is supplied to the twelve scale-band separation filters 121a-1211 where the signal is separated into frequency components of twelve scales, wherein the center frequencies of the twelve scale-band separation filters 121a-1211 are respectively the frequencies of the twelve scales.

[0158] Similarly, the outputs of the 2nd to n-th octave-band separation filters 110b to 110n, which are each an audio signal having a frequency width of one octave, are respectively supplied to the twelve scale-band separation filters 122a-1221, ... 129a-1291, wherein the center frequencies of the twelve scale-band separation filters 122a-1221, ... 129a-1291 are respectively the frequencies of the twelve scales. Further, the audio signal having a frequency width of one octave is separated into the frequency components of the twelve scales, and all octave-bands are broken down into the frequency components of the twelve scales.

[0159] In the frequency components of the twelve scales having been broken down in the aforesaid manner, signals of the same scale (i.e., octave signals) are collected for each band, and function approximation is performed by function approximation sections 130a to 1301 on each collection of the components of each scale.

[0160] To be specific, twelve function approximation sections 130a to 130l are provided in which: the function approximation section 130a performs function approximation on tone C (tone Do), the function approximation section 130b performs function approximation on tone C# (tone Do#), the function approximation section 130c performs function approximation on tone D (tone Re), the function approximation section 130d performs function approximation on tone D# (tone Re#), the function approximation section 130e performs function approximation on tone E (tone Mi), the function approximation section 130f performs function approximation on tone F (tone Fa), the function approximation section 130g performs function approximation on tone F# (tone Fa#), the function approximation section 130h performs function approximation on tone G (tone So), the function approximation section 130i performs function approximation on tone G# (tone So#), the function approximation section 130j performs function approximation on tone A (tone La), the function approximation section 130k performs function approximation on tone A# (tone La#), and the function approximation section 130l performs function approximation on tone B (tone Si).

[0161] In the function approximation sections 130a to 130l corresponding to respective scales, a number (n pieces) of audio signals divided by the octave-band separation filters 110a to 110n are obtained for respective sample points. For example, sample values of n pieces of tone C, each separated from others by an octave, are obtained in the function approximation section 130a of tone C (tone Do), and the function approximation process is performed on the sample values of n pieces of tone C. Further, parameters are outputted to an encoding section 140, wherein data amount of the parameters has been reduced by the function approximation. The same process is also performed in other function approximation sections 130b to 130l. Since the function approximation performed in the function approximation sections 130a to 130l is identical to that performed in the function approximation sections 21a to 21m shown in FIGS. 1 and 15, the description thereof will be omitted here.

[0162] Herein, the octave and the twelve scales will be described below with reference to FIGS. 21A to 21C.

[0163] FIG. 21A is a matrix, in which the vertical axis represents data of twelve scales, and the horizontal axis represents octave-band (magnification). Generally, the height of octave is expressed by a value called "note number," and the data of twelve scales is expressed by frequency.

[0164] Generally, the audio signal is divided into each octave-band, and the signal of one octave is divided into $2^{k/12}$ [i.e., (k/12)-th power of 2] pieces of scale data. In other words, when the frequency of a fundamental tone (Do) is "1" and the frequency of a fundamental tone (Do) one octave higher is "2", if dividing the interval between the two fundamental tones (Do) into twelve steps, each step will be divided into (k/12)-th power of 2 (k: 1-12) pieces.

[0165] Here, the band-separation for each octave is performed by a trapezoid shaped band separation filter determined by center frequency and bandwidth. For example, if the center frequency $f_n = 369.9944(F\#)Hz \cdot 2^n$, the frequency of the lowest tone C within one octave will be $1/\sqrt{2}$ times of the center frequency f_n , and the frequency of the highest tone B within one octave will be $\sqrt{2}$ times of the center frequency f_n . Thus, the band-dividing process for each octave can be performed under a condition in which the bandwidth is set to: $f_{0n} = f_n/\sqrt{2} \sim f_{11n} = \sqrt{2}f_n$ (C~B). In the twelve scales divided in such manner within the band, with respect to the frequency f_{0n} of the lowest tone C within one octave, the frequency f_{kn} of the k-th scale is defined by the following expression:

$$f_{kn} = f_{0n} \cdot 2^{(k/12)} \quad \dots \quad (k=0-11)$$

[0166] In FIG. 21A, the column represents a signal array of twelve scales within one octave, and the row represents a signal array of the same scale for each octave. One tone is one scale thereof, and is also a signal corresponding to any one of nine octaves, and is also a point corresponding to an intersection of the matrix shown in FIG. 21A.

[0167] Further, FIG. 21B shows the relationship between the octave magnification (band) and the amplitude when pressing C_0 (Do) key of a piano; and FIG. 21C shows the relationship between the octave magnification (band) and the amplitude when drawing C_0 (Do) tone of a cello. In the case of a piano, the amplitude is strikingly large in octave magnification 2, and the amplitude is small on average in other octave magnifications. Further, in the case of a cello, when the octave magnification is relatively small, a signal of large amplitude can be obtained in a wide range; and in octave magnifications 10 or larger, the amplitude of signal is small. In other words, characteristics of musical instruments can be faithfully expressed.

[0168] FIG. 22 is a view showing the relationship between the scale frequency range and amplitude (i.e., frequency characteristic), in the case where the band separation filters are configured to divide the signal into each octave frequency interval. As described above, tone can be divided into twelve kinds (scales). The unit of each the divided twelve steps is called a "semitone". In other words, the tone between "Do (C)" and "Do# (C#)", the tone between "Do# (C#)" and "Re (D)", ... are each called a "semitone".

[0169] The frequency of "Do (C4)" is 261 Hz, and the frequency of "Do (C5)", which is one octave higher than "Do (C4)", is 522 Hz. Further, the frequency of "La (A4)" is 440 Hz, and the frequency of "La (A3)", which is one octave lower than "La (A4)", is 220 Hz. As described above, the relationship that one frequency is twice as high as another frequency

is called "overtone". Thus, scale frequency is divided into twelve frequencies within one octave, and the octave signal become the same tone every n-times of frequencies.

[0170] As shown in FIG. 22, the tones of "Do (C1 to C10)", which have lowest frequency in the twelve scales, are arranged at the left end of each frequency band at 33Hz, 65Hz, 131Hz, 261Hz, 523Hz, 1047Hz, 2093Hz..., so that the overtone relationship is maintained. As shown in FIG. 22, the tones of "Si (B1 to B10)", which have highest frequency in the twelve scales, are arranged at the right end of each frequency band at 61Hz, 124Hz, 247Hz, 494Hz, 987Hz, 1975Hz..., so that the overtone relationship is maintained.

[0171] Returning to FIG. 20, each signal of the twelve scales having been function-approximated by the function approximation sections 130a to 130l is sent to the encoding section 140. In the encoding section 140, the parameters of all scale ranges of the twelve scales are encoded, and when performing such encoding process, a variable-length coding may be performed in which bit assignment of the signal of each gradation is determined according to signal condition of each parameter. In the case where the variable-length coding process is performed, information such as bit assignment of each gradation component and the like shall be included as the side information (auxiliary information) of the audio signal. The data encoded by the encoding section 140 is supplied to a bit-stream forming section 150, from which bit-stream data with a predetermined form is outputted.

[0172] Further, it is also possible to generate an error detection code and an error correction code in the bit-stream forming section 150 according to necessity, and add the generated error detection code or error correction code to the bit-stream. Thus, the bit-stream data outputted from the bit-stream forming section 150 is either transmitted to the receiving side through, for example, various transmission lines or stored in various storage media. A storage means provided in the encoding device is typically used as the storage media, however other methods may also be used such as transmitting the data to a database of an external device so that the data is stored.

[0173] Incidentally, the signals collected from each scale-band separation filter are directly function-approximated in the example shown in FIG. 20, however the present invention also include a configuration in which a down-sampling process is performed to thin out the sampling period of the signals collected from each scale-band separation filter, and then the function approximation process is performed on the down-sampled signals. By performing down-sampling, amount of data of the audio signal after compression can be effectively reduced.

[0174] An example of a device for decoding the signal encoded by the encoding device shown in FIG. 20 will be described below with reference to FIG. 23.

[0175] As shown in FIG. 23, the encoded bit-stream is supplied to a bit-stream input section 201. The error detection code or error correction code has been attached to the bit-stream, and in the bit-stream input section 201, an error detection process or an error correction process is performed using the attached error detection code or error correction code.

[0176] Further, the encoded data of the function-approximated parameters of the bit-stream having been subjected to the error detection process or error correction process is supplied to a decoding section 202, where the parameters are decoded for each separated band.

[0177] The parameters of each band decoded by the decoding section 202 are supplied to function interpolation sections 210a to 210l. There are twelve (twelve scales) function interpolation sections 210a to 210l provided corresponding to the function approximation sections 130a to 130l of twelve scales on the side of the encoding device shown in FIG. 20 to perform a process inverse to the approximation process performed by the function approximation sections 130a to 130l. Further, the values of the sample points of each twelve scales octave are reconstructed.

[0178] Here, only the signals of the scale bands assigned to each of the function interpolation sections 210a to 210l are included in the output of each of the function interpolation sections 210a to 210l with the interval of one octave. The output of each of the function interpolation sections 210a to 210l is supplied to n filters that separate the output for each one octave component.

[0179] To be specific, the output of the collection of the band of the scale of the tone C (Do) reconstructed by the function interpolation section 210a is supplied to n octave-band separation filters 221a to 221n. Further, the signal of the band of the scale of the tone C (Do) of a first octave-band is extracted by the octave-band separation filter 221a, and the signal of the band of the scale of the tone C (Do) of a second octave-band is extracted by the octave-band separation filter 221b. The same process is performed by each of the other filters, so that the signals of the tones C (Do) with the interval of one octave are separated for each one octave.

[0180] Similarly, the output of the collection of the band of the scale of the tone C# reconstructed by the function interpolation section 210b is supplied to n octave-band separation filters 222a to 222n, so that the signals of the tones C# with the interval of one octave are separated for each one octave. Such process is performed on the reconstructed signal of the band of each of the twelve scales. FIG. 23 shows an example in which the output of the collection of the band of the scale of the tone C# is supplied to n octave-band separation filters 232a to 232n, so that the signals are separated for each one octave.

[0181] Further, the signals of each band separated by each of octave-band separation filters 221a to 221n, 222a to 222n, ..., 232a to 232n are collected in adders 241a to 241l, which are individually provided for each octave-band, to

be summed, and an audio signal of the band of one octave is reconstructed by each adder, so that signals of bands of n octaves are obtained.

[0182] Further, the signals of bands of n octaves obtained by the adders 241a to 241l are synthesized by a synthesis filter 203 so as to obtain a digital audio signal of one system.

[0183] Incidentally, the aforesaid example gives a method of reconstructing data for each octave signal, and the method is configured to make it possible to adjust the gain for each band in the case where the audience has a hearing problem or the like. Thus, the reconstructing process is a summation operation for each band; for a normal person, each output of the function interpolation sections 210a to 210l is directly supplied to the synthesis filter 203, and it is not necessary to collect the signals in unit of octave.

[0184] The digital audio signal outputted from the synthesis filter 203 is supplied to a digital-to-analog converter 204, and the analog audio signal converted by the digital-to-analog converter 204 is outputted to an analog audio signal output terminal 205.

[0185] Thus, by performing a decoding process, which is a process inverse to the encoding process, it is possible to perform a decoding process to well reconstruct the original audio signal.

[0186] In order to sequentially show the decoding process, in the configuration example shown in FIG. 23, the band of each scale is obtained by each of the octave-band separation filters 221a to 221n, 222a to 222n, ..., 232a to 232n, and the signals of the bands of the same scale (for example, C (Do)) from each of the octave-band separation filters are summed by the adders 241a to 241l so as to obtain the signals for each one octave. Further, the signals from the adders 241a to 241l are synthesized, and the synthesized signal is supplied to the digital-to-analog converter 204. However, it is also possible to directly synthesize the output of each of the octave-band separation filters 221a to 221n, 222a to 222n, ..., 232a to 232n for each scale (for example, C (Do)) with twelve synthesis filters, without summing the output of each of the octave-band separation filters 221a to 221n, 222a to 222n, ..., 232a to 232n with the adders 241 to 241l. With such a configuration, as shown in FIG. 21B and FIG. 21C, the sound sources extracted using the frequency characteristics of each musical instrument can be effectively classified.

[0187] Incidentally, the aforesaid embodiments are described based on the examples in which the encoding configuration and decoding configuration are respectively configured by dedicated devices having the means adapted to perform the corresponding signal processes; however the present invention also includes a configuration in which a program (software) for executing signal processes corresponding to the processes performed by the encoding section and decoding section described in the aforesaid embodiments is installed on an information-processing device, such as a personal computer for performing various kinds of data processing, and the same encoding process and decoding process are performed by the software process by executing the program. The program may either be distributed through various kinds of recording media, or via a transmission medium such as the Internet.

Industrial Applicability

[0188] The compression and reproduce technique of the audio signal about the present invention has been described in details. The technical feature of the present invention lies in that the compression and reproduce can be freely performed according to height of tone (register). Obviously, such technical feature can be used not only to distribute music to an audio device or over a network, but also to broadcast guidance information in a loud environment, to form a spiritually comfortable environment such as BGB, and the like. Particularly, the technique of the present invention is very useful to hearing aid users such as elderly people and person with hearing loss having problems in discerning high pitched tone and low pitched tone.

Explanation of Reference Numerals

[0189]

1, 101	audio signal source
2, 102	analog-to-digital converter
3, 140	encoding section
4, 150	bit-stream forming section
5	side information encoding section
10	filter bank
11a~11m	bandpass filter
12a~12m	down-sampling section
20	function approximation section (21a~21m: function approximation section (for each band))
31a~31m	quantization bit assignment section

	51	bit-stream input section
	52	decoding section
	53a~53m	inverse quantization section
	22a, 22b, 54a~54m	function interpolation section
5	56	digital-to-analog converter
	57	analog audio signal output terminal
	60	filter bank
	24a, 24b, 61a~61m	up-sampling section
	62	sub-band synthesis filter
10	110a~110n	octave separation filter
	121a~1211, 122a~1221, 129a~1291	separation filters for twelve scales
	130a~1301	function approximation sections of twelve scales

15 **Claims**

1. An audio signal compression device comprising:

20 a band dividing means (10) adapted to divide a digital audio signal into a plurality of frequency bands;
a function approximation means (20) prepared for each divided band and adapted to function-approximate a predetermined interval of the digital audio signal, which has been divided into each band by the band dividing means, using an n-degree polynomial, n being an integral number equal to or more than 2; and
an encoding means (3) adapted to encode parameters which are coefficient values of the n-degree polynomial having been function-approximated by the function approximation means.

25 2. The audio signal compression device according to claim 1, wherein the predetermined interval is either an interval between a maximum value and a minimum value of the smallest frequency band among the plurality of frequency bands, or an interval between the maximum value, or the minimum value, and an inflection point of the smallest frequency band; and/or
30 wherein the n-degree polynomial is expressed by a linear combination expression of sampling functions classified by number of times at which the function is differentiable.

35 3. The audio signal compression device according to claim 2, wherein the sampling function used in the function approximation means (20) is a function including a fundamental term and a control term expressed separately from each other, and the characteristic of the sampling function is changed by setting a coefficient value of the control term.

40 4. The audio signal compression device according to any one of claims 1 to 3, further comprising:
a down-sampling means (12) adapted to thin out a sampling period of the digital audio signal divided into each band by the band dividing means (10),
wherein the function approximation means function-approximates the digital audio signal whose sampling period has been thinned out by the down-sampling means(12).

45 5. The audio signal compression device according to any one of claims 1 to 4,
wherein, the band dividing means (10) has an i-th, $i=1\sim n$, subtraction means adapted to subtract the output signal of an i-th band separation filter from the inputted digital audio signal, the i-th separation filter being adapted to separate the signal of an i-th frequency band, and
wherein the subtracted output of the i-th subtraction means is used as input signal of an (i+1)-th band separation filter to separate and output the signal of an (i+1)-th frequency band, and the signal of an n-th frequency band, i.e.,
50 the final frequency band, is separated and outputted from the subtracted output of an n-th subtraction means; or
wherein the band dividing means (10) includes:

55 a first band separation filter (11a) adapted to separate a low register signal, which is a first frequency band, from the inputted digital audio signal;
a third band separation filter (11c) adapted to separate a high register signal, which is a third frequency band, from the inputted digital audio signal;
an addition means (14a) adapted to sum the low register signal of the first frequency band separated by the first band separation filter and the high register signal of the third frequency band separated by the third band

separation filter; and
 a subtraction means (14b) adapted to subtract the summed signal of the low register signal of the first frequency band and the high register signal of the third frequency band summed by the addition means from the inputted digital audio signal,
 5 and
 wherein a mid register signal, which is a second frequency band, is separated from the subtracted output of the subtraction means; or

wherein the band dividing means includes:

10 a first band separation filter (11a) adapted to separate the signal of a first frequency band of the inputted digital audio signal;
 a first subtraction means (15a) adapted to subtract a signal obtained by function-approximating, with the function approximation means, the signal of the first frequency band separated by the first band separation filter and then function-interpolating the function-approximated signal from the inputted digital audio signal;
 15 a second band separation filter (11b) adapted to separate the signal of a second frequency band from the output of the first subtraction means; and
 a second subtraction means (15b) adapted to subtract a signal obtained by function-approximating, with the function approximation means, the signal of the second frequency band separated by the second band separation filter and then function-interpolating the function-approximated signal from the output signal of the first subtraction means,
 20 and
 wherein the signal of a third frequency band is separated from the output of the second subtraction means; or

25 wherein the band dividing means includes

a first band separation filter (11a) adapted to separate the signal of a first frequency band from the inputted digital audio signal;
 a second band separation filter (11b) adapted to separate the signal of a second frequency band from the
 30 inputted digital audio signal;
 an addition means (16) adapted to sum a first signal and a second signal, wherein the first signal is obtained by function-approximating the signal of the first frequency band separated by the first band separation filter and then function-interpolating the function-approximated signal, and the second signal is obtained by function-approximating the signal of the second frequency band separated by the second band separation filter and then
 35 function-interpolating the function-approximated signal; and
 a subtraction means (18) adapted to subtract the output of the addition means from the inputted digital audio signal,
 and
 wherein the signal of a third frequency band is separated from the output of the subtraction means; and/or

40 wherein the band dividing means includes:

a plurality of octave separation filters adapted to separate the digital audio signal into each octave frequency band; and
 45 scale-component separation filters adapted to separate the digital audio signal of each one octave band separated by the plurality of octave separation filters into twelve scales compliant bands corresponding to twelve scales,
 wherein the digital audio signal is separated in unit of the scale frequency.

- 50 **6.** The audio signal compression device according to claim 5, wherein the octave separation filter is a bandpass filter whose center frequency is the center scale frequency of a predetermined one octave scale and whose bandwidth is between a lowest band frequency and a highest band frequency, wherein the lowest band frequency is $1/\sqrt{2}$ times of the center scale frequency and the highest band frequency is $\sqrt{2}$ times of the center scale frequency.
- 55 **7.** The audio signal compression device according to claim 5 or 6, wherein the scale-component separation filters each separate the digital audio signal outputted from one octave separation filter into $(k/12)$ -th power of 2, wherein $k=0\sim 11$, times of the lowest band frequency of a predetermined one octave scale.

8. The audio signal compression device according to any one of claims 5 to 7, further comprising:

a plurality of function approximation means adapted to input the signals in unit of the scale frequency separated by the scale-component separation filters, collect the same scale of the twelve scales compliant bands from a plurality of octaves separated by the octave separation filters to obtain a collection of a band corresponding to the same scale, and function-approximate the collection of the band corresponding to the same scale by an n-degree polynomial, n being an integral number equal to or more than 2; and a compression-coding means adapted to compression-code the signals from the plurality of function approximation means.

9. An audio signal compression method comprising the steps of:

dividing an inputted digital audio signal into a plurality of frequency bands with band separation filters; function-approximating an arbitrary interval of the digital audio signal, which has been divided into the plurality of frequency bands, for each divided band using an n-degree polynomial, n being an integral number equal to or more than 2; and encoding parameters of the function having been function-approximated for each band.

10. An audio signal compression method according to claim 9, further comprising the step of:

performing a down-sampling process to thin out a sampling period of the digital audio signal divided into each band, wherein the function approximation is performed on the digital audio signal whose sampling period has been thinned out by the down-sampling process.

11. An audio signal compression method according to claim 9 or 10, wherein the step of dividing the inputted digital audio signal into the plurality of frequency bands with the band separation filters comprises:

a first band-separating process step (11a) of separating the signal of a first frequency band from the inputted digital audio signal; a first subtraction process step (13a) of subtracting the digital audio signal of the first frequency band separated by the first band-separating process from the inputted digital audio signal; a second band-separating process step (11b) of separating the signal of a second frequency band from the signal obtained by performing the first subtraction process; and a second subtraction process step (13b) of subtracting the digital audio signal of the second frequency band separated by the second band-separating process from the inputted digital audio signal, wherein the digital audio signal of a third frequency band, which is different from the first and second frequency bands, is band-separated by performing the second subtraction process; or wherein the step of dividing the inputted digital audio signal into the plurality of frequency bands with the band separation filters comprises:

a first band-separating process step (11a) of separating a low register signal, which is a first frequency band, from the inputted digital audio signal; a third band-separating process (11c) step of separating a high register signal, which is a third frequency band, from the inputted digital audio signal; an addition process step (14a) of summing the low register signal, which is the first frequency band, separated by the first band-separating process and the high register signal, which is the third frequency band, separated by the second band-separating process; and a subtraction process step (14b) of subtracting the summed signal of the low register signal of the first frequency band and the high register signal of the third frequency band from the inputted digital audio signal, wherein a mid register signal, which is a second frequency band of the inputted digital audio signal, is separated by the subtraction process; or

wherein the step of dividing the inputted digital audio signal into the plurality of frequency bands with the band separation filters comprises:

a first band-separating process step (11a) of separating the signal of a first frequency band of the inputted digital audio signal;

a first subtraction process step (15a) of subtracting a signal, which is obtained by function-approximating, with the function approximation means, the signal of the first frequency band separated by the first band-separating process and then function-interpolating the function-approximated signal, from the inputted digital audio signal;

a second band-separating process step (11b) of separating the signal of a second frequency band from the output obtained by performing the first subtraction process; and

a second subtraction process step (15b) of subtracting a signal, which is obtained by function-approximating the signal of the second frequency band separated by the second band-separating process and then function-interpolating the function-approximated signal, from the signal obtained by performing the first subtraction process,

wherein the signal of a third frequency band, which is different from the first and second frequency bands, is separated by performing the second subtraction process; or

wherein the step of dividing the inputted digital audio signal into the plurality of frequency bands with the band separation filters comprises:

a first band-separating process step (11a) of separating the signal of a first frequency band of the inputted digital audio signal;

a second band-separating process step (11b) of separating the signal of a second frequency band of the inputted digital audio signal;

an addition process step (16) of summing a first signal and a second signal, wherein the first signal is obtained by function-approximating the signal of the first frequency band separated by the first band-separating process and then function-interpolating the function-approximated signal, and the second signal is obtained by function-approximating the signal of the second frequency band separated by the second band-separating process and then function-interpolating the function-approximated signal; and

a subtraction process step (18) of subtracting the output signal summed by the addition process from the inputted digital audio signal,

wherein the signal of a third frequency band, which is different from the first and second frequency bands, is separated by performing the subtraction process.

12. An audio signal decoding device comprising:

a decoding means (52) adapted to decode parameters of a function of each of a plurality of divided bands of a digital audio signal, wherein the parameters of the function correspond to a compressed digital audio signal which is obtained by: function-approximating a predetermined interval of the digital audio signal divided into the plurality of frequency bands by using an n-degree polynomial, n being an integral number equal to or more than 2, and then encoding and compressing parameters which represent the coefficient values of the n-degree polynomial;

a function interpolation means (54) adapted to function-interpolate the compressed digital audio signal based on the parameters of the function of each of the divided bands decoded by the decoding means, and reconstruct sampling values of each of the divided bands; and

a band-synthesizing means (60) adapted to band-synthesize the sampling values reconstructed by the function interpolation means.

13. The audio signal decoding device according to claim 12, wherein the decoding means is further adapted to decode an audio signal compression-coded for each collection of twelve scales compliant bands obtained by collecting, from a plurality of octaves, each twelve scales compliant band of one octave, wherein the function interpolation means (54) is further adapted to perform function interpolation for each collection of the twelve scales compliant bands decoded by the decoding means; and

wherein the band synthesizing means (60) is further adapted to synthesize the collections of twelve scales compliant bands from the function interpolation means and collect digital audio signal for each octave.

14. An audio signal decoding method comprising the steps of:

decoding parameters of a function of each of a plurality of divided bands of a digital audio signal, wherein the parameters of the function correspond to a compressed digital audio signal which is obtained by: function-approximating a predetermined interval of the digital audio signal divided into the plurality of frequency bands by using an n-degree polynomial, n being an integral number equal to or more than 2, and then encoding and

compressing parameters which represent the coefficient values of the n-degree polynomial;
 function-interpolating the compressed digital audio signal based on the decoded parameters of the function of
 each of the divided bands, and reconstructing sampling values of each of the divided bands; and
 band-synthesizing the sampling values reconstructed by the function interpolation.

5

15. The audio signal decoding method according to claim 14, wherein an audio signal compression-coded for each
 collection of twelve scales compliant bands obtained by collecting, from a plurality of octaves, each twelve scales
 compliant band of one octave is decoded in the decoding step,
 wherein function interpolation for each collection of the twelve scales compliant bands decoded by the decoding
 step is performed in the function interpolation step;
 wherein the collection of twelve scales compliant bands obtained by the function interpolation is synthesized and
 outputs divided into a plurality of pieces for each band of octave are synthesized and a digital audio signal for each
 octave is collected in the band synthesizing step.

10

15

Patentansprüche

1. Audiosignal-Kompressionsvorrichtung, die umfasst:

20

eine Bandunterteilungseinrichtung (10), die dafür ausgelegt ist, ein digitales Audiosignal in mehrere Frequenz-
 bänder zu unterteilen;

eine Funktionsapproximationseinrichtung (20), die für jedes unterteilte Band vorgesehen ist und dafür ausgelegt
 ist, für ein vorgegebenes Intervall des digitalen Audiosignals, das durch die Bandunterteilungseinrichtung in die
 einzelnen Bänder unterteilt worden ist, unter Verwendung eines Polynom n-ten Grades, wobei n eine ganze
 Zahl gleich oder größer als 2 ist, eine Funktionsapproximation auszuführen; und

25

eine Bandcodierungseinrichtung (3), die dafür ausgelegt ist, Parameter, die Koeffizientenwerte des Polynoms
 n-ten Grades sind, für das durch die Funktionsapproximationseinrichtung eine Funktionsapproximation ausge-
 führt worden ist, zu codieren.

30

2. Audiosignal-Kompressionsvorrichtung nach Anspruch 1, wobei das vorgegebene Intervall entweder ein Intervall
 zwischen einem Maximalwert und einem Minimalwert des kleinsten Frequenzbandes unter den mehreren Frequenz-
 bändern oder ein Intervall zwischen dem Maximalwert oder dem Minimalwert und einem Wendepunkt des kleinsten
 Frequenzbandes ist; und/oder

35

wobei das Polynom n-ten Grades durch einen Linearkombinationsausdruck von Abtastfunktionen, die durch die
 Anzahl klassifiziert sind, in der die Funktion differenzierbar ist, gegeben ist.

40

3. Audiosignal-Kompressionsvorrichtung nach Anspruch 2, wobei die Abtastfunktion, die in der Funktionsapproxima-
 tionseinrichtung (20) verwendet wird, eine Funktion ist, die einen Grundterm und einen Steuerterm, die getrennt
 voneinander gegeben sind, enthält, und die Charakteristik der Abtastfunktion durch Einstellen eines Koeffizienten-
 wertes des Steuerterms geändert wird.

4. Audiosignal-Kompressionsvorrichtung nach einem der Ansprüche 1 bis 3, die ferner umfasst:

45

eine Abwärtsabtastungseinrichtung (12), die dafür ausgelegt ist, eine Abtastzeitperiode des digitalen Audiosi-
 gnals, das durch die Bandunterteilungseinrichtung (10) in die einzelnen Bänder worden unterteilt ist, auszu-
 dünnen,

wobei die Funktionsapproximationseinrichtung für das digitale Audiosignal, dessen Abtastperiode durch die
 Abwärtsabtastungseinrichtung (12) ausgedünnt worden ist, eine Funktionsapproximation ausgeführt.

50

5. Audiosignal-Kompressionsvorrichtung nach einem der Ansprüche 1 bis 4,
 wobei die Bandunterteilungseinrichtung (10) eine i-te, $i = 1$ bis n, Subtraktionseinrichtung besitzt, die dafür ausgelegt
 ist, das Ausgangssignal eines i-ten Bandtrennfilters von dem eingegebenen digitalen Audiosignal zu subtrahieren,
 wobei das i-te Trennfilter dafür ausgelegt ist, das Signal eines i-ten Frequenzbandes zu trennen, und
 wobei ein subtrahierter Ausgang der i-ten Subtraktionseinrichtung als ein Eingangssignal eines (i+1)-ten Bandtrenn-
 filters verwendet wird, um das Signal eines (i+1)-ten Frequenzbandes zu trennen und auszugeben, und wobei das
 Signal eines n-ten Frequenzbandes, d. h. des letzten Frequenzbandes, von dem subtrahierten Ausgang einer n-
 ten Subtraktionseinrichtung getrennt wird und ausgegeben wird; oder
 wobei die Bandunterteilungseinrichtung (10) umfasst:

55

EP 2 306 453 B1

ein erstes Bandtrennfilter (11a), das dafür ausgelegt ist, ein niedriges Registersignal, das ein erstes Frequenzband ist, von dem eingegebenen digitalen Audiosignal zu trennen;
ein drittes Bandtrennfilter (11c), das dafür ausgelegt ist, ein hohes Registersignal, das ein drittes Frequenzband ist, von dem eingegebenen digitalen Audiosignal zu trennen;
5 eine Additionseinrichtung (14a), die dafür ausgelegt ist, das niedrige Registersignal des ersten Frequenzbandes, das durch das erste Bandtrennfilter getrennt worden ist, und das hohe Registersignal des dritten Frequenzbandes, das durch das dritte Bandtrennfilter getrennt worden ist, zu summieren; und
eine Subtraktionseinrichtung (14b), die dafür ausgelegt ist, das Summensignal aus dem niedrigen Registersignal des ersten Frequenzbandes und dem hohen Registersignal des dritten Frequenzbandes, die durch die Additionseinrichtung summiert worden sind, von dem eingegebenen digitalen Audiosignal zu subtrahieren,
10 und
wobei ein mittleres Registersignal, das ein zweites Frequenzband ist, von dem subtrahierten Ausgang der Subtraktionseinrichtung getrennt wird; oder

15 wobei die Bandunterteilungseinrichtung umfasst:

ein erstes Bandtrennfilter (11 a), das dafür ausgelegt ist, das Signal eines ersten Frequenzbandes des eingegebenen digitalen Audiosignals zu trennen;
eine erste Subtraktionseinrichtung (15a), die dafür ausgelegt ist, ein Signal, das durch Ausführen einer Funktionsapproximation mit der Funktionsapproximationseinrichtung an dem Signal des ersten Frequenzbandes, das durch das erste Bandtrennfilter getrennt worden wird, und dann durch Ausführen einer Funktionsinterpolation an dem Signal, an dem eine Funktionsapproximation ausgeführt worden ist, erhalten wird, von dem eingegebenen digitalen Audiosignal zu subtrahieren;
20 ein zweites Bandtrennfilter (11 b), das dafür ausgelegt ist, das Signal eines zweiten Frequenzbandes von dem Ausgang der ersten Subtraktionseinrichtung zu trennen; und
eine zweite Subtraktionseinrichtung (15b), die dafür ausgelegt ist, ein Signal, das durch Ausführen einer Funktionsapproximation mit der Funktionsapproximationseinrichtung an dem Signal des zweiten Frequenzbandes, das durch das zweite Bandtrennfilter getrennt worden wird, und dann durch Ausführen einer Funktionsinterpolation an dem Signal, an dem eine Funktionsapproximation ausgeführt worden ist, erhalten wird, von dem Ausgangssignal der ersten Subtraktionseinrichtung zu subtrahieren,
25 und
wobei das Signal eines dritten Frequenzbandes von dem Ausgang der zweiten Subtraktionseinrichtung getrennt wird; oder

35 wobei die Bandunterteilungseinrichtung umfasst:

ein erstes Bandtrennfilter (11a), das dafür ausgelegt ist, das Signal eines ersten Frequenzbandes von dem eingegebenen digitalen Audiosignal zu trennen;
ein zweites Bandtrennfilter (11 b), das dafür ausgelegt ist, das Signal eines zweiten Frequenzbandes von dem eingegebenen digitalen Audiosignal zu trennen;
40 eine Additionseinrichtung (16), die dafür ausgelegt ist, ein erstes Signal und ein zweites Signal zu summieren, wobei das erste Signal durch Ausführen einer Funktionsapproximation an dem Signal des ersten Frequenzbandes, das durch das erste Bandtrennfilter getrennt worden ist, und dann durch Ausführen einer Funktionsinterpolation an dem Signal, an dem eine Funktionsapproximation ausgeführt worden ist, erhalten wird und das zweite Signal durch Ausführen einer Funktionsapproximation an dem Signal des zweiten Frequenzbandes, das durch das zweite Bandtrennfilter getrennt worden ist, und dann durch Ausführen einer Funktionsinterpolation an dem Signal, an dem eine Funktionsapproximation ausgeführt worden ist, erhalten wird; und
45 eine Subtraktionseinrichtung (18), die dafür ausgelegt ist, den Ausgang der Additionseinrichtung von dem eingegebenen digitalen Audiosignal zu subtrahieren,
50 und
wobei das Signal eines dritten Frequenzbandes von dem Ausgang der Subtraktionseinrichtung getrennt wird; und/oder

55 wobei die Bandunterteilungseinrichtung umfasst:

mehrere Oktaventrennfilter, die dafür ausgelegt sind, das digitale Audiosignal in einzelne Oktavenfrequenzbänder zu trennen; und
Tonleiterkomponenten-Trennfilter, die dafür ausgelegt sind, das digitale Audiosignal jedes Oktavenbandes, die

durch die mehreren Oktaventrennfilter getrennt worden sind, in mit zwölf Tonleitern konforme Bänder, die zwölf Tonleitern entsprechen, zu trennen, wobei das digitale Audiosignal in Einheiten der Tonleiterfrequenz getrennt wird.

5 6. Audiosignal-Kompressionsvorrichtung nach Anspruch 5, wobei das Oktaventrennfilter ein Bandpassfilter ist, dessen Mittenfrequenz die mittlere Tonleiterfrequenz einer vorgegebenen Oktaventonleiter ist und dessen Bandbreite zwischen einer niedrigsten Bandfrequenz und einer höchsten Bandfrequenz liegt, wobei die niedrigste Bandfrequenz
10 gleich der $1/\sqrt{2}$ -fachen mittleren Tonleiterfrequenz ist und die höchste Bandfrequenz gleich der $\sqrt{2}$ -fachen mittleren Tonleiterfrequenz ist.

7. Audiosignal-Kompressionsvorrichtung nach Anspruch 5 oder 6, wobei die Tonleiterkomponenten-Trennfilter jeweils das von einem Oktaventrennfilter ausgegebene digitale Audiosignal in das $(k/12)$ -te-Potenz-von-2-Fache der niedrigsten Bandfrequenz einer vorgegebenen Oktaventonleiter trennen, wobei $k = 1$ bis 11.

15 8. Audiosignal-Kompressionsvorrichtung nach einem der Ansprüche 5 des 7, die ferner umfasst:
mehrere Funktionsapproximationseinrichtungen, die dafür ausgelegt sind, die Signale in Einheiten der Tonleiterfrequenz, die durch Tonleiterkomponenten-Trennfilter getrennt worden sind, einzugeben, dieselbe Tonleiter
20 der mit zwölf Tonleitern konformen Bänder aus mehreren Oktaven, die durch die Oktaventrennfilter getrennt worden sind, zu sammeln, um eine Sammlung eines Bandes, die derselben Tonleiter entspricht, zu erhalten, und für die Sammlung des Bandes, die derselben Tonleiter entspricht, durch ein Polynom n -ten Grades, wobei n eine ganze Zahl gleich oder größer als 2 ist, eine Funktionsapproximation auszuführen; und
eine Kompressionscodierungseinrichtung, die dafür ausgelegt ist, die Signale von den mehreren Funktionsapproximationseinrichtungen durch Kompression zu codieren.

9. Audiosignal-Kompressionsverfahren, das die folgenden Schritte umfasst:
Unterteilen eines eingegebenen digitalen Audiosignals in mehrere Frequenzbänder mit Bandtrennfiltern;
30 Ausführen einer Funktionsapproximation an einem beliebigen Intervall des digitalen Audiosignals, das in die mehreren Frequenzbänder unterteilt worden ist, für jedes unterteilte Band unter Verwendung eines Polynoms n -ten Grades, wobei n eine ganze Zahl gleich oder größer als 2 ist; und
Codieren von Parametern der Funktion, für die für die einzelnen Bänder eine Funktionsapproximation ausgeführt worden ist.

35 10. Audiosignal-Kompressionsverfahren nach Anspruch 9, das ferner den folgenden Schritt umfasst:
Ausführen eines Abwärtsabtastungsprozesses, um eine Abtastperiode des digitalen Audiosignals, das in die einzelnen Bänder unterteilt worden ist, auszudünnen,
40 wobei die Funktionsapproximation an dem digitalen Audiosignal ausgeführt wird, dessen Abtastperiode durch den Abwärtsabtastungsprozess ausgedünnt worden ist.

45 11. Audiosignal-Kompressionsverfahren nach Anspruch 9 oder 10, wobei der Schritt des Unterteilens des eingegebenen digitalen Audiosignals in die mehreren Frequenzbänder mit den Bandtrennfiltern umfasst:
einen ersten Bandtrennprozess-Schritt (11a) des Trennens eines Signals eines ersten Frequenzbandes von dem eingegebenen digitalen Audiosignal;
einen ersten Subtraktionsprozess-Schritt (13a) des Subtrahierens des digitalen Audiosignals des ersten Frequenzbandes, das durch den ersten Bandtrennprozess getrennt worden ist, von dem eingegebenen digitalen Audiosignal;
50 einen zweiten Bandtrennprozess-Schritt (11 b) des Trennens des Signals eines zweiten Frequenzbandes von dem Signal, das durch Ausführen des ersten Subtraktionsprozesses erhalten wird; und
einen zweiten Subtraktionsprozess-Schritt (13b) des Subtrahierens des digitalen Audiosignals des zweiten Frequenzbandes, das durch den zweiten Bandtrennprozess getrennt worden ist, von dem eingegebenen digitalen Audiosignal,
55 wobei das digitale Audiosignal eines dritten Frequenzbandes, das von dem ersten und dem zweiten Frequenzband verschieden ist, durch Ausführen des zweiten Subtraktionsprozesses bandgetrennt wird; oder
wobei der Schritt des Unterteilens des eingegebenen digitalen Audiosignals in die mehreren Frequenzbänder

mit den Bandtrennfiltern umfasst:

5 einen ersten Bandtrennprozess-Schritt (11a) des Trennens eines niedrigen Registersignals, das ein erstes Frequenzband ist, von dem eingegebenen digitalen Audiosignal;
 einen dritten Bandtrennprozess-Schritt (11 c) des Trennens eines hohen Registersignals, das ein drittes Frequenzband ist, von dem eingegebenen digitalen Audiosignal;
 einen Additionsprozess-Schritt (14a) des Summierens des niedrigen Registersignals, das das erste Frequenzband ist und durch den ersten Bandtrennprozess getrennt worden ist, und des hohen Registersignals, das das dritte Frequenzband ist und durch den zweiten Bandtrennprozess getrennt worden ist; und
 10 einen Subtraktionsprozess-Schritt (14b) des Subtrahierens des Summensignals aus dem niedrigen Registersignal des ersten Frequenzbandes und aus dem hohen Registersignal des dritten Frequenzbandes von dem eingegebenen digitalen Audiosignal,
 wobei ein mittleres Registersignal, das ein zweites Frequenzband des eingegebenen digitalen Audiosignals ist, durch den Subtraktionsprozess getrennt wird; oder

15 wobei der Schritt des Unterteilens des eingegebenen digitalen Audiosignals in die mehreren Frequenzbänder mit den Bandtrennfiltern umfasst:

20 einen ersten Bandtrennprozess-Schritt (11a) des Trennens des Signals eines ersten Frequenzbandes des eingegebenen digitalen Audiosignals;
 einen ersten Subtraktionsprozess-Schritt (15a) des Subtrahierens eines Signals, das durch Ausführen einer Funktionsapproximation mit der Funktionsapproximationseinrichtung an dem Signal des ersten Frequenzbandes, das durch den ersten Bandtrennprozess getrennt worden ist, und dann durch Ausführen einer Funktionsinterpolation an dem Signal, an dem eine Funktionsapproximation ausgeführt worden ist, erhalten
 25 wird, von dem eingegebenen digitalen Audiosignal;
 einen zweiten Bandtrennprozess-Schritt (11 b) des Trennens des Signals eines zweiten Frequenzbandes von dem Ausgang, der durch Ausführen des ersten Subtraktionsprozesses erhalten wird; und
 einen zweiten Subtraktionsprozess-Schritt (15b) des Subtrahierens eines Signals, das durch Ausführen einer Funktionsapproximation mit der Funktionsapproximationseinrichtung an dem Signal des zweiten Frequenzbandes, das durch den zweiten Bandtrennprozess getrennt worden ist, und dann durch Ausführen einer Funktionsinterpolation an dem Signal, an dem eine Funktionsapproximation ausgeführt worden ist, erhalten
 30 wird, von dem Signal, das durch Ausführen des ersten Subtraktionsprozesses erhalten wird, wobei das Signal eines dritten Frequenzbandes, das von dem ersten und dem zweiten Frequenzband verschieden ist, durch Ausführen des zweiten Subtraktionsprozesses getrennt wird; oder

35 wobei der Schritt des Unterteilens des eingegebenen digitalen Audiosignals in die mehreren Frequenzbänder mit den Bandtrennfiltern umfasst:

40 einen ersten Bandtrennprozess-Schritt (11a) des Trennens des Signals eines ersten Frequenzbandes des eingegebenen digitalen Audiosignals;
 einen zweiten Bandtrennprozess-Schritt (11 b) des Trennens des Signals eines zweiten Frequenzbandes des eingegebenen digitalen Audiosignals;
 einen Additionsprozess-Schritt (16) des Summierens eines ersten Signals und eines zweiten Signals, wobei
 45 das erste Signal durch Ausführen einer Funktionsapproximation an dem Signal des ersten Frequenzbandes, das durch den ersten Bandtrennprozess getrennt worden ist, und dann durch Ausführen einer Funktionsinterpolation an dem Signal, an dem eine Funktionsapproximation ausgeführt worden ist, erhalten wird und
 das zweite Signal durch Ausführen einer Funktionsapproximation an dem Signal des zweiten Frequenzbandes, das durch den zweiten Bandtrennprozess getrennt worden ist, und dann durch Ausführen einer Funktionsinterpolation an dem Signal, an dem eine Funktionsapproximation ausgeführt worden ist, erhalten
 50 wird; und
 einen Subtraktionsprozess-Schritt (18) des Subtrahierens des Ausgangssignals, das durch den Additionsprozess summiert worden ist, von dem eingegebenen digitalen Audiosignal,
 wobei das Signal eines dritten Frequenzbandes, das von dem ersten und dem zweiten Frequenzband
 55 verschieden ist, durch Ausführen des Subtraktionsprozesses erhalten wird.

12. Audiosignal-Decodierungsvorrichtung, die umfasst:

eine Decodierungseinrichtung (52), die dafür ausgelegt ist, Parameter einer Funktion jedes von mehreren un-

terteilten Bändern eines digitalen Audiosignals zu decodieren, wobei die Parameter der Funktion einem komprimierten digitalen Audiosignal entsprechen, das erhalten wird durch: Ausführen einer Funktionsapproximation eines vorgegebenen Intervalls des in die mehreren Frequenzbänder unterteilten digitalen Audiosignals unter Verwendung eines Polynoms n-ten Grades, wobei n eine ganze Zahl gleich oder größer als 2 ist, und dann Codieren und Komprimieren von Parametern, die die Koeffizientenwerte des Polynoms n-ten Grades darstellen; eine Funktionsinterpolationseinrichtung (54), die dafür ausgelegt ist, für das komprimierte digitale Audiosignal anhand der Parameter der Funktion jedes der durch die Decodierungseinrichtung decodierten unterteilten Bänder eine Funktionsinterpolation auszuführen und Abtastwerte jedes der unterteilten Bänder zu rekonstruieren; und eine Bandsynthesierungseinrichtung (60), die dafür ausgelegt ist, eine Bandsynthesierung der durch die Funktionsinterpolationseinrichtung rekonstruierten Abtastwerte auszuführen.

13. Audiosignal-Decodierungsvorrichtung nach Anspruch 12, wobei die Decodierungseinrichtung ferner dafür ausgelegt ist, ein kompressionscodiertes Audiosignal für jede Sammlung von mit zwölf Tonleitern konformen Bändern, die durch Sammeln aus mehreren Oktaven jedes mit zwölf Tonleitern konformen Bandes einer Oktave erhalten werden, zu decodieren, wobei die Funktionsinterpolationseinrichtung (54) ferner dafür ausgelegt ist, eine Funktionsinterpolation für jede Sammlung der mit zwölf Tonleitern konformen Bänder, die durch die Decodierungseinrichtung decodiert worden sind, auszuführen; und wobei die Bandsynthesierungseinrichtung (60) ferner dafür ausgelegt ist, die Sammlungen von mit zwölf Tonleitern konformen Bändern von der Funktionsinterpolationseinrichtung zu synthetisieren und für jede Oktave digitale Audiosignale zu sammeln.

14. Audiosignal-Decodierungsverfahren, das die folgenden Schritte umfasst:

Decodieren von Parametern einer Funktion jedes von mehreren unterteilten Bändern eines digitalen Audiosignals, wobei die Parameter der Funktion einem komprimierten digitalen Audiosignal entsprechen, das erhalten wird durch: Ausführen einer Funktionsapproximation eines vorgegebenen Intervalls des digitalen Audiosignals, das in die mehreren Frequenzbänder unterteilt worden ist, unter Verwendung eines Polynoms n-ten Grades, wobei n eine ganze Zahl gleich oder größer als 2 ist, und dann Codieren und Komprimieren von Parametern, die die Koeffizientenwerte des Polynoms n-ten Grades darstellen; Ausführen einer Funktionsinterpolation des komprimierten digitalen Audiosignals anhand der decodierten Parameter der Funktion jedes der unterteilten Bänder und Rekonstruieren von Abtastwerten jedes der unterteilten Bänder; und Ausführen einer Bandsynthesierung der Abtastwerte, die durch die Funktionsinterpolation rekonstruiert werden.

15. Audiosignal-Decodierungsverfahren nach Anspruch 14, wobei in dem Decodierungsschritt ein Audiosignal, das für jede Sammlung von mit zwölf Tonleitern konformen Bändern, die durch Sammeln aus mehreren Oktaven jedes mit zwölf Tonleitern konformen Bandes einer Oktave erhalten wird, kompressionscodiert ist, decodiert wird, wobei in dem Funktionsinterpolationsschritt eine Funktionsinterpolation für jede Sammlung der mit zwölf Tonleitern konformen Bänder, die durch den Decodierungsschritt decodiert werden, ausgeführt wird; wobei die Sammlung von mit zwölf Tonleitern konformen Bändern, die durch die Funktionsinterpolation erhalten wird, synthetisiert wird und Ausgänge, die in mehrere Teile für jedes Band einer Oktave unterteilt sind, synthetisiert werden und ein digitales Audiosignal für jede Oktave in dem Bandsynthesierungsschritt gesammelt wird.

Revendications

1. Dispositif de compression de signal audio comprenant :

un moyen de division de bande (10) adapté pour diviser un signal audio numérique en une pluralité de bandes de fréquence ;
un moyen d'approximation par fonction (20) préparé pour chaque bande divisée et adapté pour approximer par fonction un intervalle prédéterminé du signal audio numérique, qui a été divisé en chaque bande par le moyen de division de bande, en utilisant un polynôme de degré n, n étant un nombre entier supérieur ou égal à 2 ; et un moyen d'encodage (3) adapté pour encoder des paramètres qui sont des valeurs de coefficient du polynôme de degré n ayant été approximé par fonction par le moyen d'approximation par fonction.

EP 2 306 453 B1

2. Dispositif de compression de signal audio selon la revendication 1, dans lequel l'intervalle prédéterminé est soit un intervalle entre une valeur maximale et une valeur minimale de la plus petite bande de fréquence parmi la pluralité de bandes de fréquence, soit un intervalle entre la valeur maximale, ou la valeur minimale, et un point d'inflexion de la plus petite bande de fréquence ; et/ou
- 5 dans lequel le polynôme de degré n est exprimé par une expression de combinaison linéaire de fonctions d'échantillonnage classées par le nombre de fois où la fonction est dérivable.
3. Dispositif de compression de signal audio selon la revendication 2, dans lequel la fonction d'échantillonnage utilisée dans le moyen d'approximation par fonction (20) est une fonction incluant un terme fondamental et un terme de contrôle exprimés séparément l'un de l'autre, et la caractéristique de la fonction d'échantillonnage est modifiée en
- 10 fixant une valeur de coefficient du terme de contrôle.
4. Dispositif de compression de signal audio selon l'une quelconque des revendications 1 à 3, comprenant en outre :
- 15 un moyen de sous-échantillonnage (12) adapté pour amincir une période d'échantillonnage du signal audio numérique divisé en chaque bande par le moyen de division de bande (10), dans lequel le moyen d'approximation par fonction approxime par fonction le signal audio numérique dont la période d'échantillonnage a été amincie par le moyen de sous-échantillonnage (12).
- 20 5. Dispositif de compression de signal audio selon l'une quelconque des revendications 1 à 4, dans lequel, le moyen de division de bande (10) comporte un i -ième, $i = 1-n$, moyen de soustraction adapté pour soustraire le signal de sortie d'un i -ième filtre de séparation de bande du signal audio numérique entré, le i -ième filtre de séparation étant adapté pour séparer le signal d'une i -ième bande de fréquence, et
- 25 dans lequel la sortie soustraite du i -ième moyen de soustraction est utilisée comme signal d'entrée d'un $(i + 1)$ -ième filtre de séparation de bande pour séparer et produire en sortie le signal d'une $(i + 1)$ -ième bande de fréquence, et le signal d'une n -ième bande de fréquence, c'est-à-dire, la bande de fréquence finale, est séparé et produit en sortie à partir de la sortie soustraite d'un n -ième moyen de soustraction ; ou
- 30 dans lequel le moyen de division de bande (10) inclut :
- un premier filtre de séparation de bande (11a) adapté pour séparer un signal de registre grave, qui est une première bande de fréquence, du signal audio numérique entré ;
- un troisième filtre de séparation de bande (11c) adapté pour séparer un signal de registre aigu, qui est une troisième bande de fréquence, du signal audio numérique entré ;
- 35 un moyen d'addition (14a) adapté pour sommer le signal de registre grave de la première bande de fréquence séparé par le premier filtre de séparation de bande et le signal de registre aigu de la troisième bande de fréquence séparé par le troisième filtre de séparation de bande ; et
- un moyen de soustraction (14b) adapté pour soustraire le signal sommé du signal de registre grave de la première bande de fréquence et le signal de registre aigu de la troisième bande de fréquence sommé par le moyen d'addition du signal audio numérique entré,
- 40 et
- dans lequel un signal de registre médian, qui est une deuxième bande de fréquence, est séparé de la sortie soustraite du moyen de soustraction ; ou
- dans lequel le moyen de division de bande inclut :
- 45 un premier filtre de séparation de bande (11a) adapté pour séparer le signal d'une première bande de fréquence du signal audio numérique entré ;
- un premier moyen de soustraction (15a) adapté pour soustraire un signal obtenu par approximation par fonction, avec le moyen d'approximation par fonction, du signal de la première bande de fréquence séparé par le premier
- 50 filtre de séparation de bande puis par interpolation par fonction du signal approximé par fonction à partir du signal audio numérique entré ;
- un deuxième filtre de séparation de bande (11b) adapté pour séparer le signal d'une deuxième bande de fréquence de la sortie du premier moyen de soustraction ; et
- un second moyen de soustraction (15b) adapté pour soustraire un signal obtenu par approximation par fonction, avec le moyen d'approximation par fonction, du signal de la deuxième bande de fréquence séparé par le
- 55 deuxième filtre de séparation de bande puis par interpolation par fonction du signal approximé par fonction du signal sorti du premier moyen de soustraction,
- et

dans lequel le signal d'une troisième bande de fréquence est séparé de la sortie du second moyen de soustraction ; ou

dans lequel le moyen de division de bande inclut :

- 5
- un premier filtre de séparation de bande (11a) adapté pour séparer le signal d'une première bande de fréquence du signal audio numérique entré ;
 - un deuxième filtre de séparation de bande (11b) adapté pour séparer le signal d'une deuxième bande de fréquence du signal audio numérique entré ;
 - 10 un moyen d'addition (16) adapté pour sommer un premier signal et un second signal, dans lequel le premier signal est obtenu par approximation par fonction du signal de la première bande de fréquence séparé par le premier filtre de séparation de bande puis par interpolation par fonction du signal approximé par fonction, et le second signal est obtenu par approximation par fonction du signal de la deuxième bande de fréquence séparé par le deuxième filtre de séparation de bande puis par interpolation par fonction du signal approximé par fonction ;
 - 15 et
 - un moyen de soustraction (18) adapté pour soustraire la sortie du moyen d'addition du signal audio numérique entré,
 - et
 - dans lequel le signal d'une troisième bande de fréquence est séparé de la sortie du moyen de soustraction ; et/ou

20 dans lequel le moyen de division de bande inclut :

- une pluralité de filtres de séparation d'octave adaptés pour séparer le signal audio numérique en chaque bande de fréquence d'octave ; et
- 25 des filtres de séparation de composante de gamme adaptés pour séparer le signal audio numérique de chaque bande d'octave séparée par la pluralité de filtres de séparation d'octave en bandes conformes aux douze gammes correspondant à douze gammes,
- dans lequel le signal audio numérique est séparé en unité de la fréquence de gamme.

30 **6.** Dispositif de compression de signal audio selon la revendication 5, dans lequel le filtre de séparation d'octave est un filtre passe-bande dont la fréquence centrale est la fréquence de gamme centrale d'une gamme d'octave prédéterminée et dont la bande passante se situe entre une plus basse fréquence de bande et une plus haute fréquence de bande, dans lequel la plus basse fréquence de bande est $1/\sqrt{2}$ fois la fréquence de gamme centrale et la plus haute fréquence de bande est $\sqrt{2}$ fois la fréquence de gamme centrale.

35 **7.** Dispositif de compression de signal audio selon la revendication 5 ou 6, dans lequel les filtres de séparation de composante de gamme séparent chacun le signal audio numérique sorti à partir d'un filtre de séparation d'octave en $(k/12)$ -ième puissance de 2, dans lequel $k = 0-11$, fois la plus basse bande de fréquence d'une gamme d'octave prédéterminée.

40 **8.** Dispositif de compression de signal audio selon l'une quelconque des revendications 5 à 7, comprenant en outre :

- une pluralité de moyens d'approximation par fonction adaptés pour entrer les signaux en unité de la fréquence de gamme séparés par les filtres de séparation de composante de gamme, rassembler la même gamme des bandes conformes aux douze gammes à partir d'une pluralité d'octaves séparées par les filtres de séparation d'octave pour obtenir un ensemble d'une bande correspondant à la même gamme, et approximer par fonction de l'ensemble de la bande correspondant à la même gamme par un polynôme de degré n , n étant un nombre entier supérieur ou égal à 2 ; et
- 45 un moyen de codage par compression adapté pour coder par compression les signaux provenant de la pluralité de moyens d'approximation par fonction.

50 **9.** Procédé de compression de signal audio comprenant les étapes de :

- 55 division d'un signal audio numérique entré en une pluralité de bandes de fréquence avec des filtres de séparation de bande ;
- approximation par fonction d'un intervalle arbitraire du signal audio numérique, qui a été divisé en la pluralité de bandes de fréquence, pour chaque bande divisée en utilisant un polynôme de degré n , n étant un nombre entier supérieur ou égal à 2 ; et

encodage de paramètres de la fonction approximée par fonction pour chaque bande.

10. Procédé de compression de signal audio selon la revendication 9, comprenant en outre l'étape de :

5 réalisation d'un processus de sous-échantillonnage pour amincir une période d'échantillonnage du signal audio numérique divisé en chaque bande, dans lequel l'approximation par fonction est réalisée sur le signal audio numérique dont la période d'échantillonnage a été amincie par le processus de sous-échantillonnage.

10 11. Procédé de compression de signal audio selon la revendication 9 ou 10, dans lequel l'étape de division du signal audio numérique entré en la pluralité de bandes de fréquence avec les filtres de séparation de bande comprend :

une première étape de processus de séparation de bande (11a) consistant à séparer le signal d'une première bande de fréquence du signal audio numérique entré ;

15 une première étape de processus de soustraction (13a) consistant à soustraire le signal audio numérique de la première bande de fréquence séparé par le premier processus de séparation de bande du signal audio numérique entré ;

une deuxième étape de processus de séparation de bande (11b) consistant à séparer le signal d'une deuxième bande de fréquence du signal obtenu en réalisant le premier processus de soustraction ; et

20 une seconde étape de processus de soustraction (13b) consistant à soustraire le signal audio numérique de la deuxième bande de fréquence séparé par le deuxième processus de séparation de bande du signal audio numérique entré,

25 dans lequel le signal audio numérique d'une troisième bande de fréquence, qui est différente des première et deuxième bandes de fréquence, est séparé en bande en réalisant le deuxième processus de soustraction ; ou dans lequel l'étape de division du signal audio numérique entré en la pluralité de bandes de fréquence avec les filtres de séparation de bande comprend :

une première étape de processus de séparation de bande (11a) consistant à séparer un signal de registre grave, qui est une première bande de fréquence, du signal audio numérique entré ;

30 une troisième étape de processus de séparation de bande (11c) consistant à séparer un signal de registre aigu, qui est une troisième bande de fréquence, du signal audio numérique entré ;

une étape de processus d'addition (14a) consistant à sommer le signal de registre grave, qui est la première bande de fréquence, séparé par le premier processus de séparation de bande et le signal de registre aigu, qui est la troisième bande de fréquence, séparé par le deuxième processus de séparation de bande ; et

35 une étape de processus de soustraction (14b) consistant à soustraire le signal sommé du signal de registre grave de la première bande de fréquence et le signal de registre aigu de la troisième bande de fréquence du signal audio numérique entré,

40 dans lequel un signal de registre médian, qui est une deuxième bande de fréquence du signal audio numérique entré, est séparé par le processus de séparation ; ou

dans lequel l'étape de division du signal audio numérique entré en la pluralité de bandes de fréquence avec les filtres de séparation de bande comprend :

45 une première étape de processus de séparation de bande (11a) consistant à séparer le signal d'une première bande de fréquence du signal audio numérique entré ;

une première étape de processus de soustraction (15a) consistant à soustraire un signal, qui est obtenu par approximation par fonction, avec le moyen d'approximation par fonction, du signal de la première bande de fréquence séparé par le premier processus de séparation de bande puis par interpolation par fonction du signal approximé par fonction, du signal audio numérique entré ;

50 une deuxième étape de processus de séparation de bande (11b) consistant à séparer le signal d'une deuxième bande de fréquence de la sortie obtenue en réalisant le premier processus de soustraction ; et une seconde étape de processus de soustraction (15b) consistant à soustraire un signal, qui est obtenu par approximation par fonction du signal de la deuxième bande de fréquence séparé par le deuxième processus de séparation de bande, puis par interpolation par fonction du signal approximé par fonction, du signal obtenu en réalisant le premier processus de soustraction,

55 dans lequel le signal d'une troisième bande de fréquence, qui est différente des première et deuxième bandes de fréquence, est séparé en réalisant le second processus de soustraction ; ou

dans lequel l'étape de division du signal audio numérique entré en la pluralité de bandes de fréquence avec les filtres de séparation de bande comprend :

5 une première étape de processus de séparation de bande (11a) consistant à séparer le signal d'une première bande de fréquence du signal audio numérique entré ;
 une deuxième étape de processus de séparation de bande (11b) consistant à séparer le signal d'une deuxième bande de fréquence du signal audio numérique entré ;
 10 une étape de processus d'addition (16) consistant à sommer un premier signal et un second signal, dans lequel le premier signal est obtenu par approximation par fonction du signal de la première bande de fréquence séparé par le premier processus de séparation de bande puis par interpolation par fonction du signal approximé par fonction, et le second signal est obtenu par approximation par fonction du signal de la deuxième bande de fréquence séparé par le deuxième processus de séparation de bande puis par interpolation par fonction du signal approximé par fonction ; et
 15 une étape de processus de soustraction (18) consistant à soustraire le signal de sortie sommé par le processus d'addition du signal audio numérique entré, dans lequel le signal d'une troisième bande de fréquence, qui est différente des première et deuxième bandes de fréquence, est séparé en réalisant le processus de soustraction.

12. Dispositif de décodage de signal audio comprenant :

20 un moyen de décodage (52) adapté pour décoder des paramètres d'une fonction de chacune d'une pluralité de bandes divisées d'un signal audio numérique, dans lequel les paramètres de la fonction correspondent à un signal audio numérique compressé qui est obtenu par : approximation par fonction d'un intervalle prédéterminé du signal audio numérique divisé en la pluralité de bandes de fréquence en utilisant un polynôme de degré n , n étant un nombre entier supérieur ou égal à 2, puis par encodage et compression des paramètres qui
 25 représentent les valeurs de colonne du polynôme de degré n ;
 un moyen d'interpolation par fonction (54) adapté pour interpoler par fonction le signal audio numérique compressé d'après les paramètres de la fonction de chacune des bandes divisées décodés par le moyen de décodage, et pour reconstruire des valeurs d'échantillonnage de chacune des bandes divisées ; et
 30 un moyen de synthèse de bande (60) adapté pour synthétiser la bande des valeurs d'échantillonnage reconstruites par le moyen d'interpolation par fonction.

13. Dispositif de décodage de signal audio selon la revendication 12, dans lequel le moyen de décodage est en outre adapté pour décoder un signal audio codé par compression pour chaque ensemble de bandes conformes aux douze gammes obtenues en rassemblant, à partir d'une pluralité d'octaves, chaque bande conforme aux douze gammes d'un octave, dans lequel le moyen d'interpolation par fonction (54) est en outre adapté pour réaliser une interpolation par fonction pour chaque ensemble des bandes conformes aux douze gammes décodées par le moyen de décodage ;
 35 et
 dans lequel le moyen de synthèse de bande (60) est en outre adapté pour synthétiser les ensembles de bandes conformes aux douze gammes à partir du moyen d'interpolation par fonction et rassembler un signal audio numérique pour chaque octave.
 40

14. Procédé de décodage de signal audio comprenant les étapes de :

45 décodage de paramètres d'une fonction de chacune d'une pluralité de bandes divisées d'un signal audio numérique, dans lequel les paramètres de la fonction correspondent à un signal audio numérique compressé qui est obtenu par : approximation par fonction d'un intervalle prédéterminé du signal audio numérique divisé en la pluralité de bandes de fréquence en utilisant un polynôme de degré n , n étant un nombre entier supérieur ou égal à 2, puis par encodage et compression des paramètres qui représentent les valeurs de colonne du polynôme de degré n ;
 50 interpolation par fonction du signal audio numérique compressé d'après les paramètres décodés de la fonction de chacune des bandes divisées, et reconstruction des valeurs d'échantillonnage de chacune des bandes divisées ; et
 synthèse de bande des valeurs d'échantillonnage reconstruites par l'interpolation par fonction.
 55

15. Procédé de décodage de signal audio selon la revendication 14, dans lequel un signal audio codé par compression pour chaque ensemble de bandes conformes aux douze gammes obtenues en rassemblant, à partir d'une pluralité d'octaves, chaque bande conforme aux douze gammes d'une octave est décodé à l'étape de décodage,

EP 2 306 453 B1

dans lequel l'interpolation par fonction pour chaque ensemble des bandes conformes aux douze gammes décodées par l'étape de décodage est réalisée à l'étape d'interpolation par fonction ;
dans lequel l'ensemble des bandes conformes aux douze gammes obtenues par l'interpolation par fonction est synthétisé et les sorties divisées en une pluralité de morceaux pour chaque bande d'octave sont synthétisées et un signal audio numérique pour chaque octave est rassemblé à l'étape de synthèse de bande.

5

10

15

20

25

30

35

40

45

50

55

FIG. 1

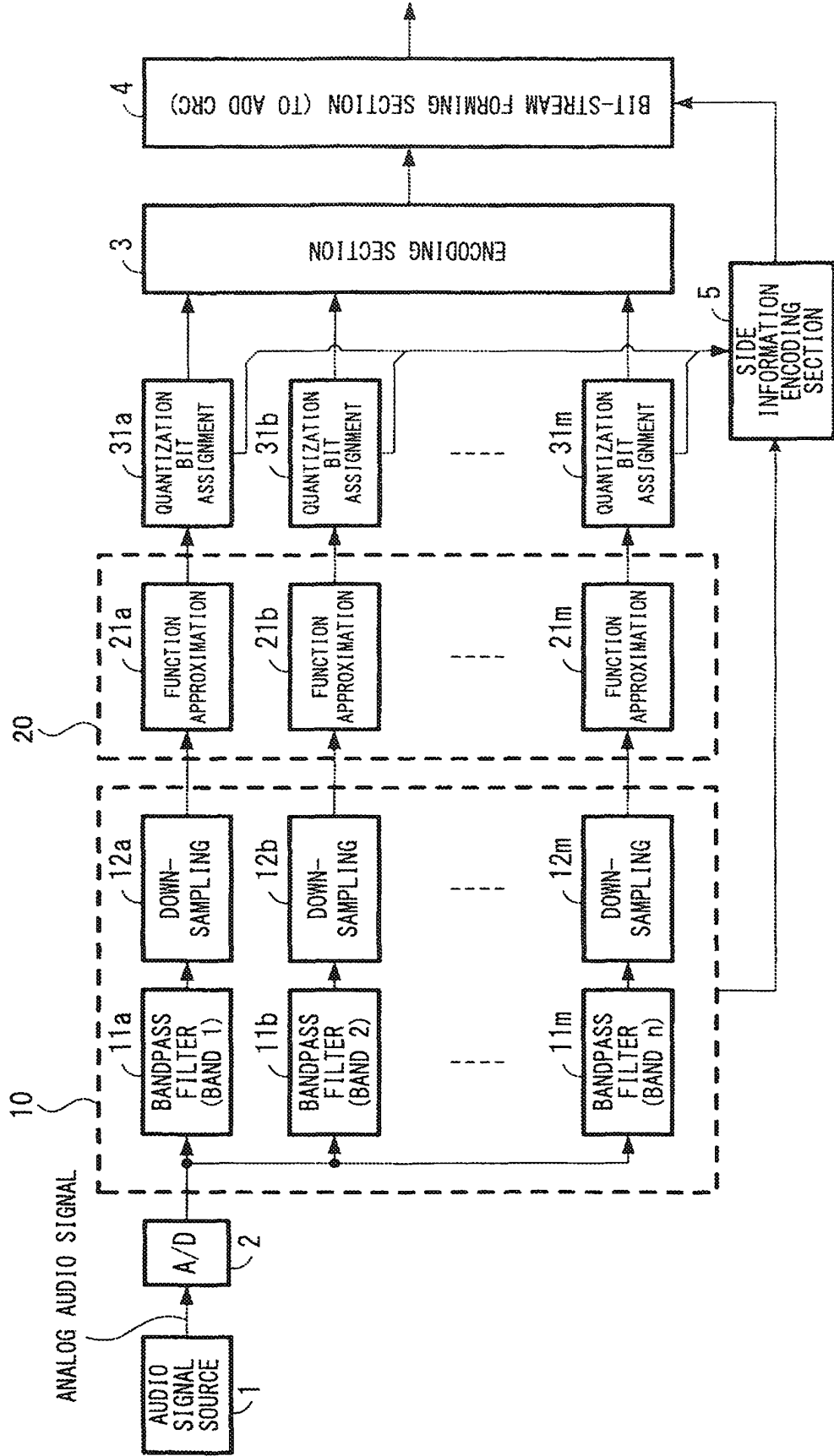
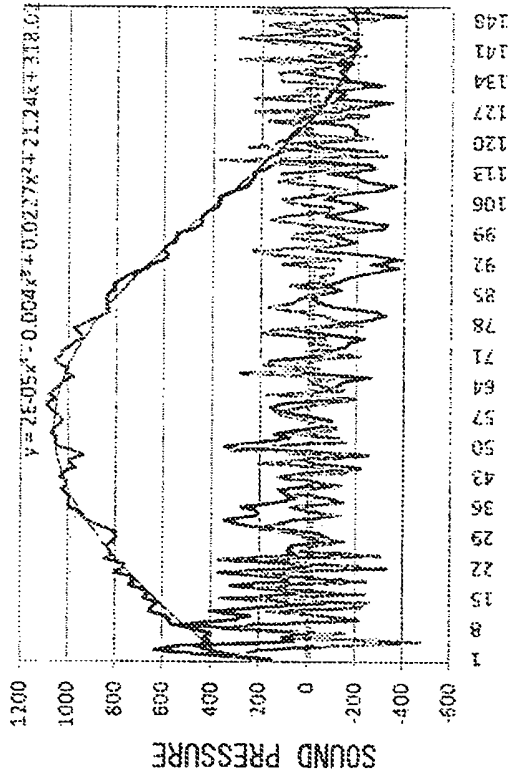
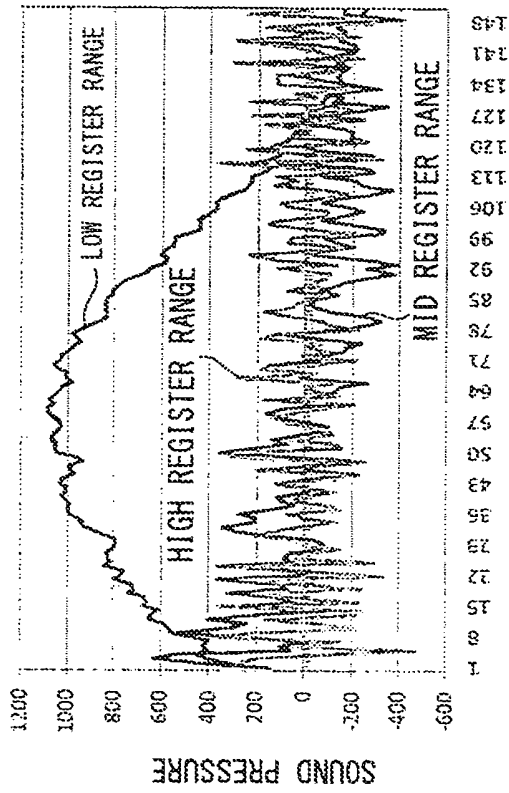

FIG. 2B



TIME (SAMPLING FREQUENCY: 44.1 kHz)

FIG. 2A



TIME (SAMPLING FREQUENCY: 44.1 kHz)

FIG. 3

BANK NUMBER	6	1	3	2	2	0~16	COEFFICIENT VALUE	SHIFT AMOUNT	BIT-WIDTH	COEFFICIENT VALUE	SHIFT AMOUNT	BIT-WIDTH	COEFFICIENT VALUE	SHIFT AMOUNT	BIT-WIDTH	COEFFICIENT VALUE	SHIFT AMOUNT	BIT-WIDTH	COEFFICIENT VALUE
FUNCTION FORM	ORDER	SHIFT AMOUNT	BIT-WIDTH	COEFFICIENT VALUE	SHIFT AMOUNT	BIT-WIDTH	COEFFICIENT VALUE	SHIFT AMOUNT	BIT-WIDTH	COEFFICIENT VALUE	SHIFT AMOUNT	BIT-WIDTH	COEFFICIENT VALUE	SHIFT AMOUNT	BIT-WIDTH	COEFFICIENT VALUE	SHIFT AMOUNT	BIT-WIDTH	COEFFICIENT VALUE
6	1	3	2	2	0~16	2	2	2	0~16	2	2	2	0~16	2	2	0~16	2	2	0~16
ITEM	BIT NUMBER	EXPLANATION																	
BANK NUMBER	6	0~127 BANK NUMBER OF BAND DIVIDING FILTER																	
FUNCTION FORM	1	0 : SAMPLING FUNCTION APPROXIMATION 1 : POLYNOMIAL FUNCTION APPROXIMATION																	
ORDER	3	WHEN FUNCTION FORM IS 0: MAXIMUM OF TIMES (m-1) BY WHICH THE SAMPLING FUNCTION CAN BE DIFFERENTIATED WHEN FUNCTION FORM IS 1: MAXIMUM DEGREE OF POLYNOMIAL																	
SHIFT AMOUNT	2	0 : NO SHIFT 1 : 8-BITS SHIFTED 2 : 16-BITS SHIFTED 3 : 32-BITS SHIFTED																	
BIT-WIDTH	2	0 : 4BITS 1:8BITS 2:12BITS 3:16BITS																	
COEFFICIENT VALUE	0~16	COEFFICIENT VALUE																	
0A	1	4	3	3	447C	3	1	50	2	2	2A1	2	0	F	0	2	13E		

FIG. 4A

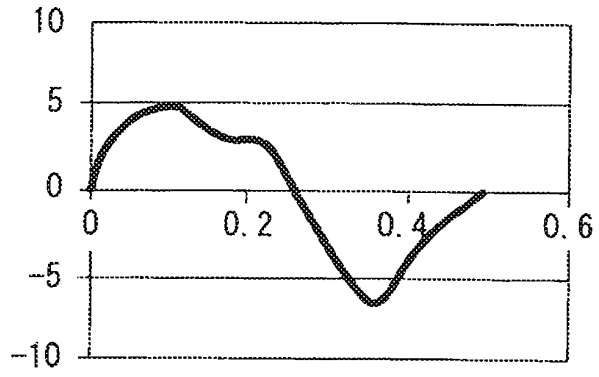

FIG. 4B

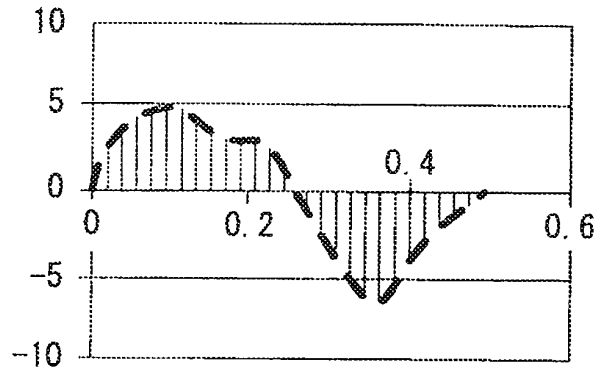

FIG. 4C

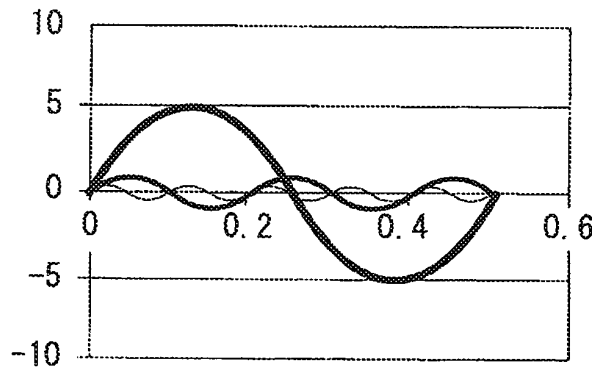

FIG. 4D

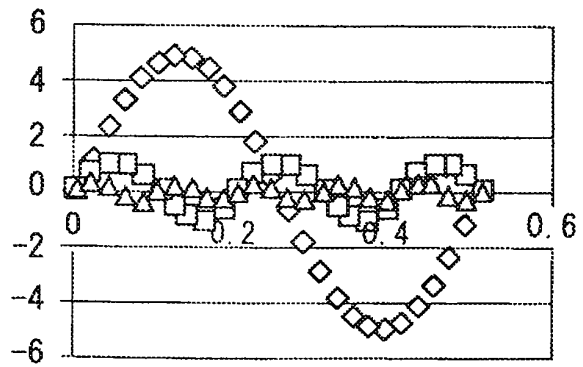

FIG. 5

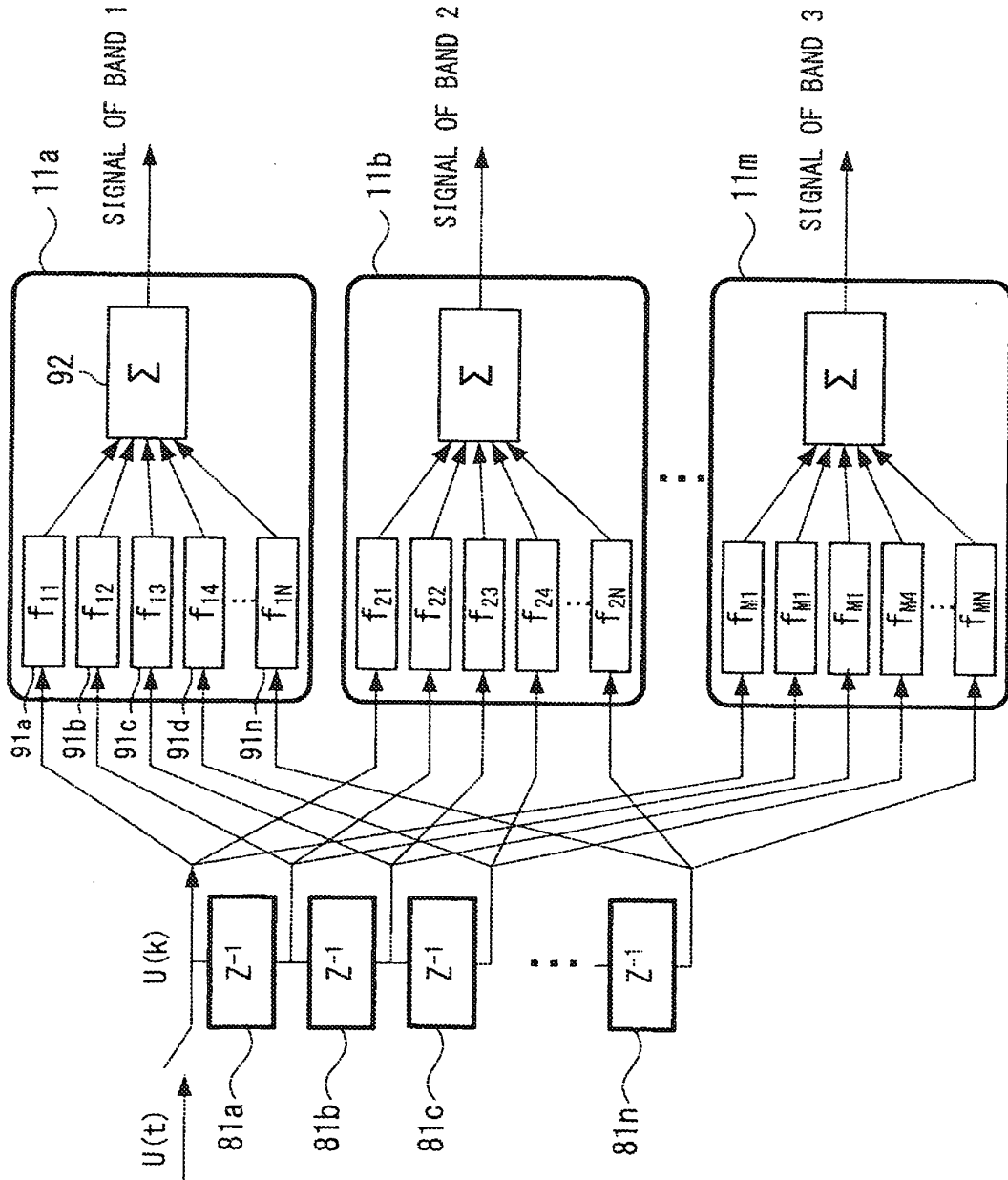

FIG. 6

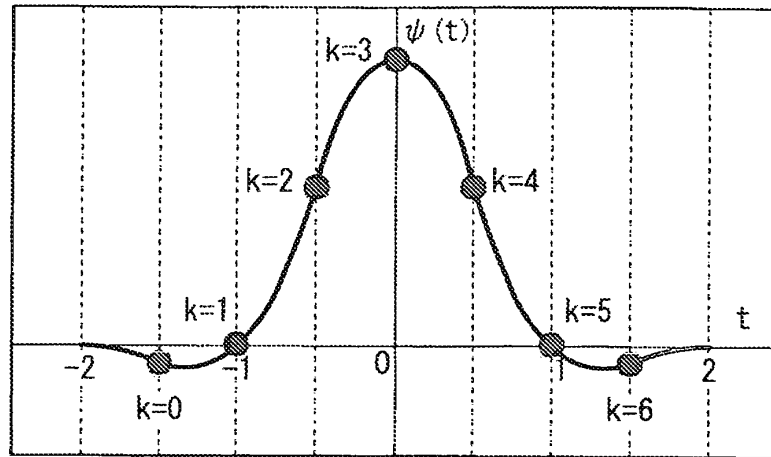

FIG. 7

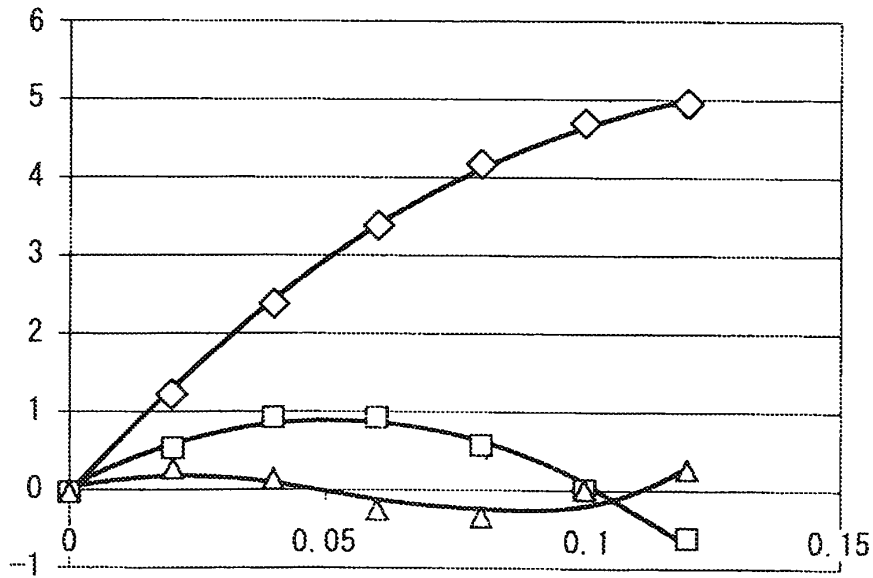

FIG. 8A

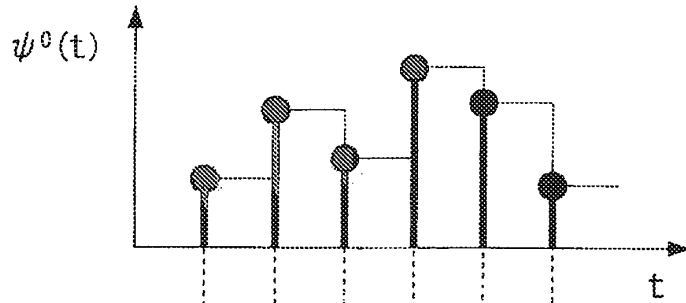

FIG. 8B

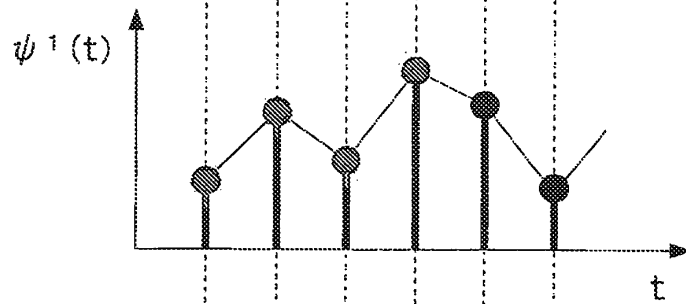

FIG. 8C

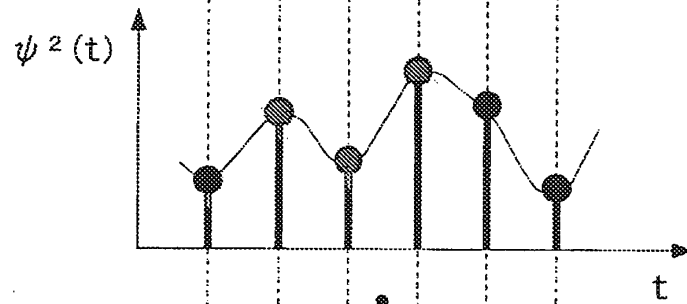

FIG. 8D

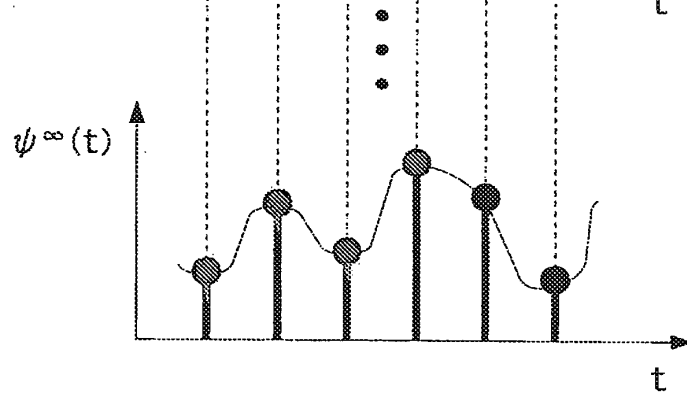

FIG. 9

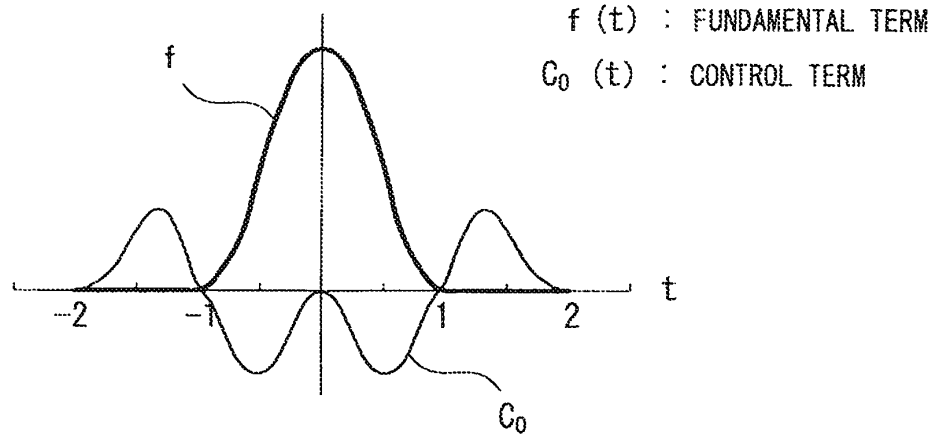

FIG. 10

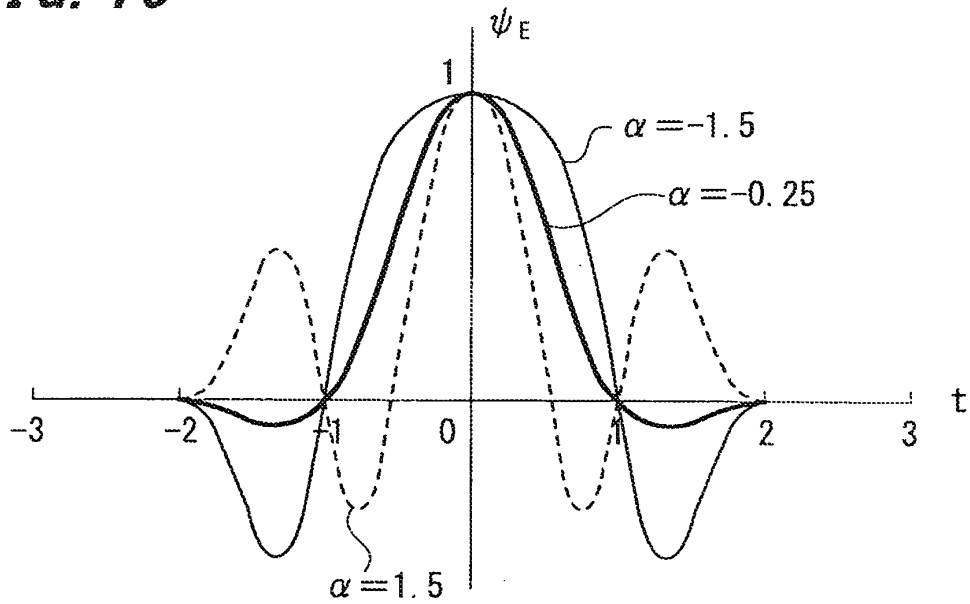

FIG. 11

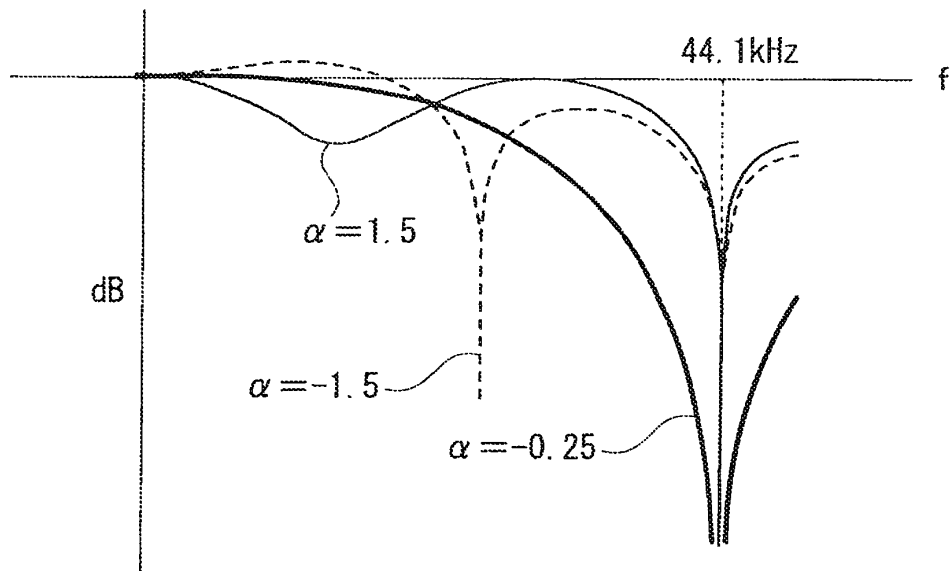

FIG. 12A

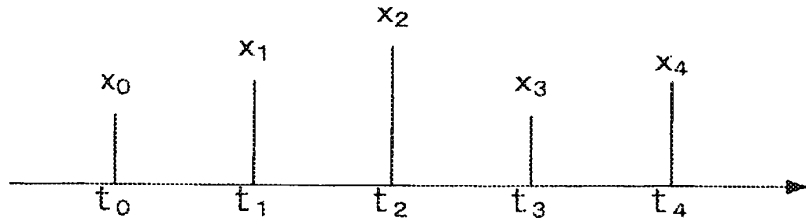

FIG. 12B

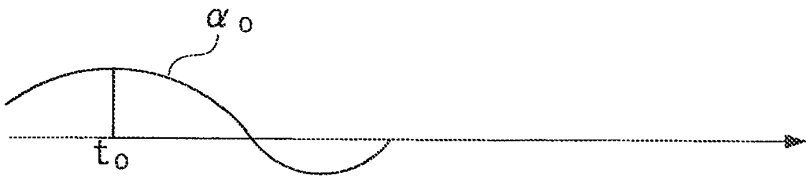

FIG. 12C

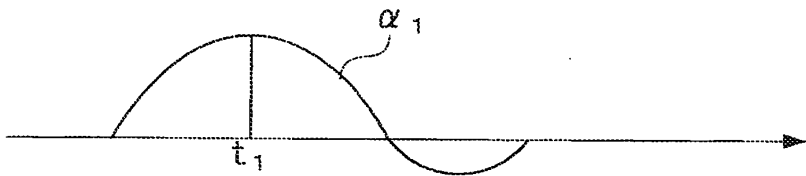

FIG. 12D

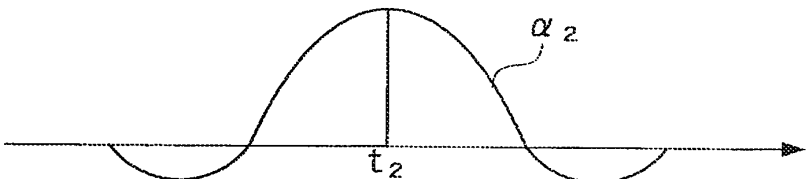

FIG. 12E

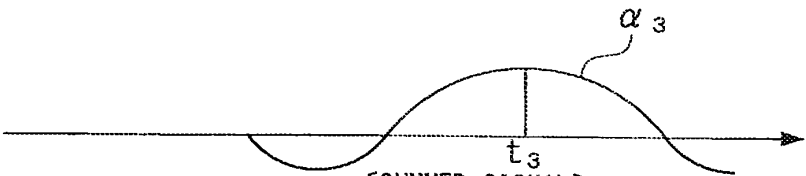

FIG. 12F

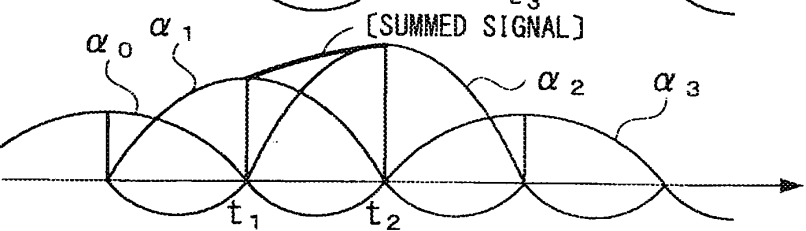

FIG. 13

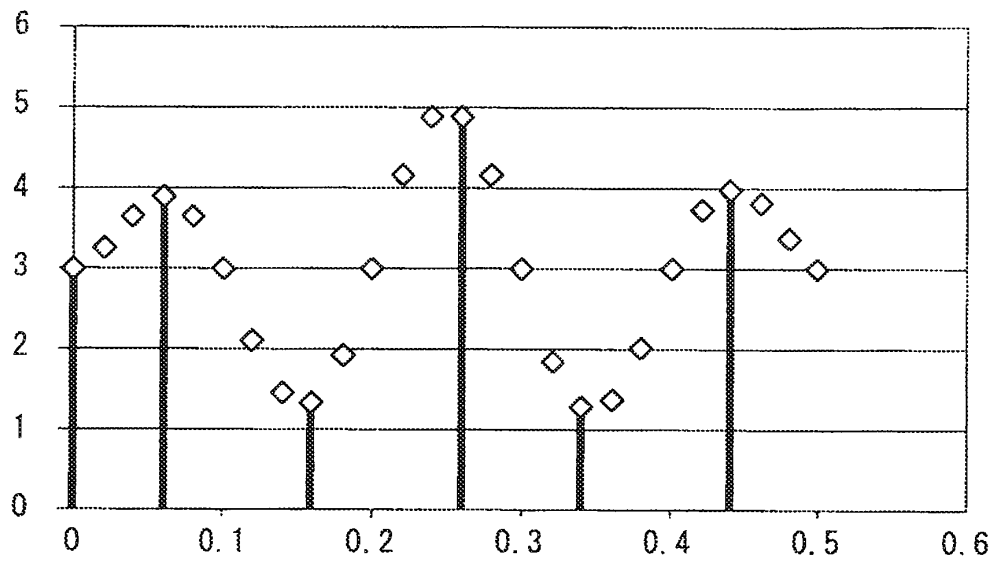

FIG. 14

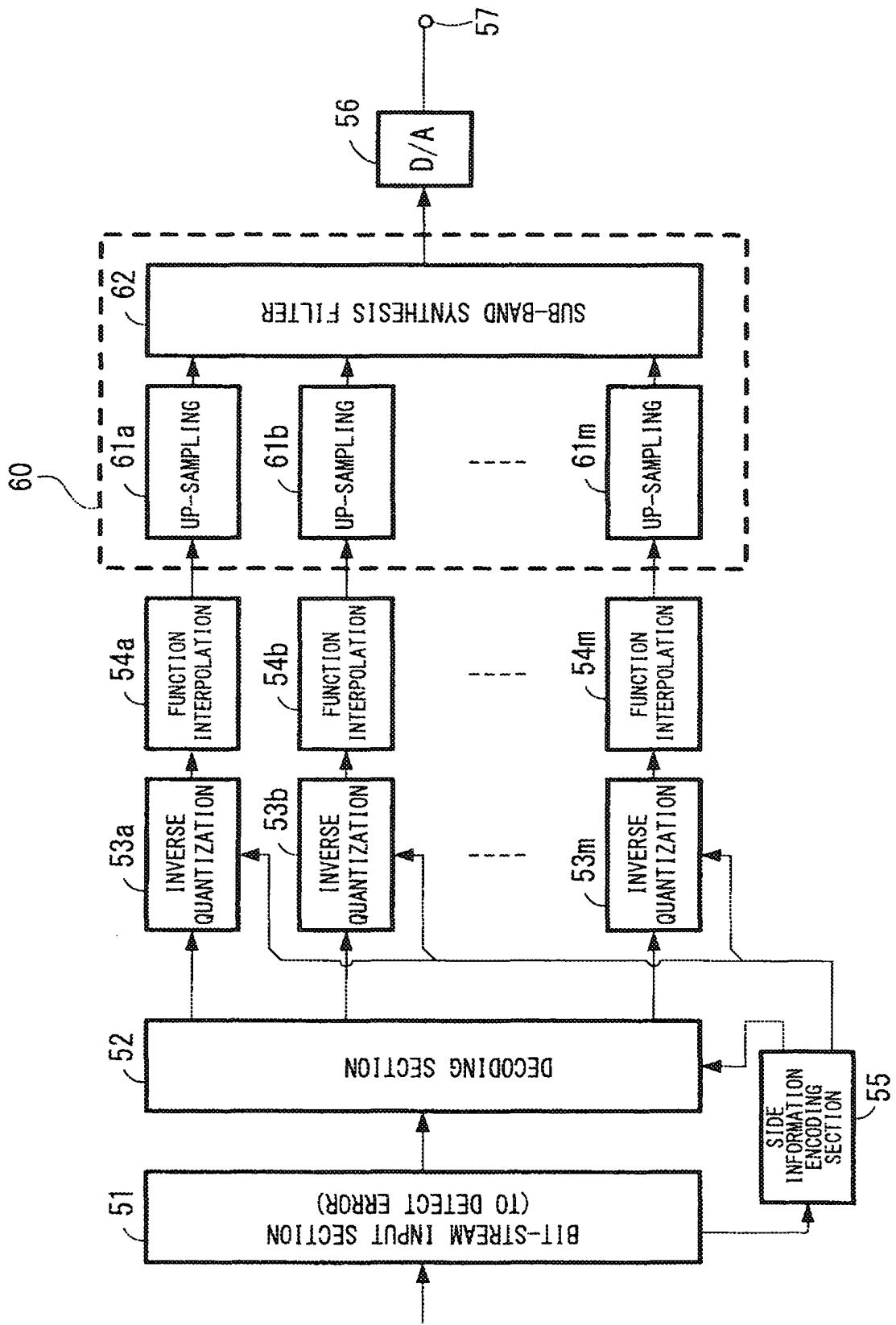

FIG. 15

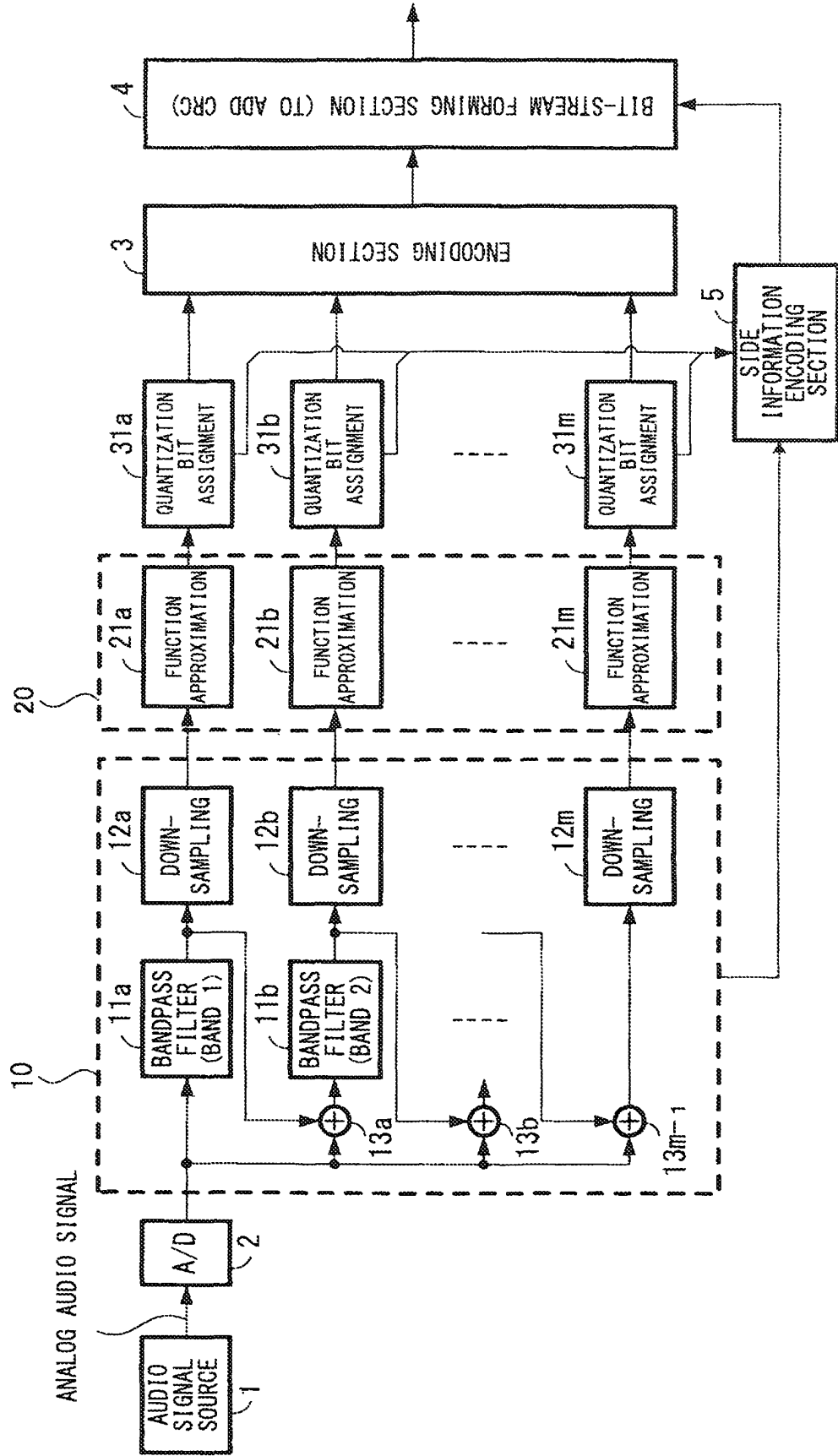

FIG. 16

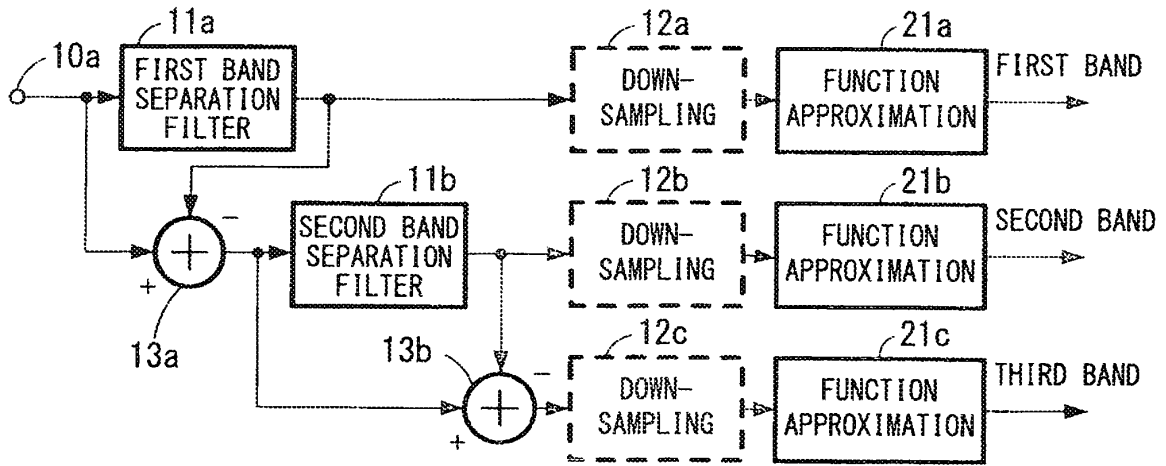

FIG. 17

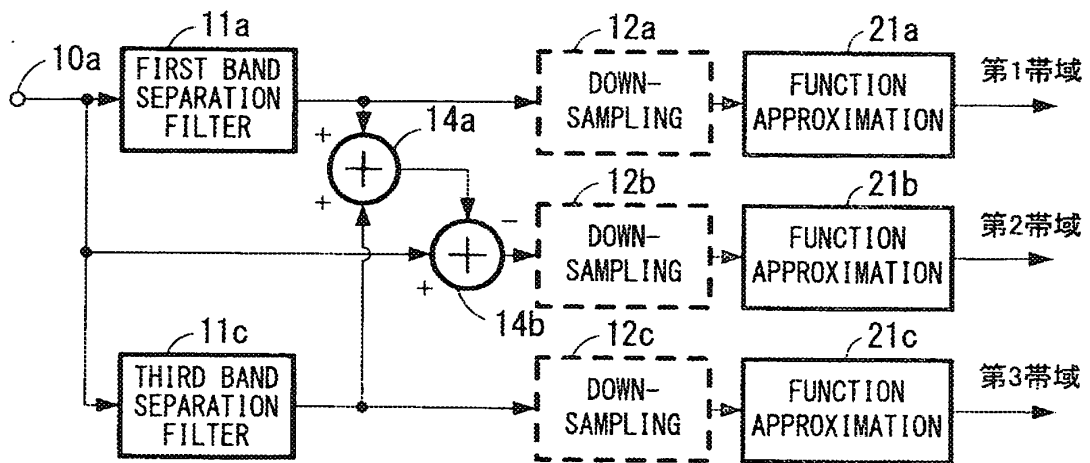

FIG. 18

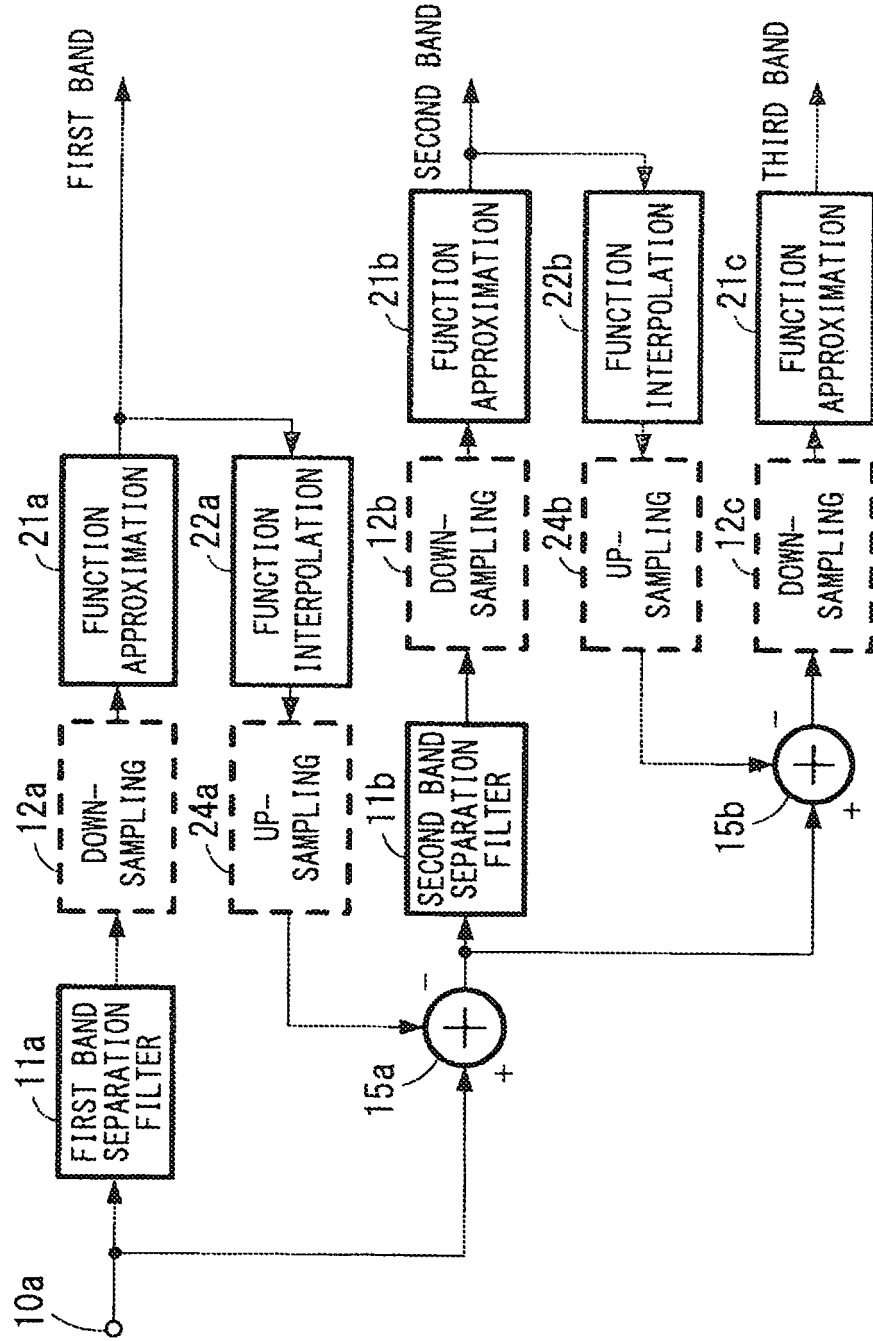
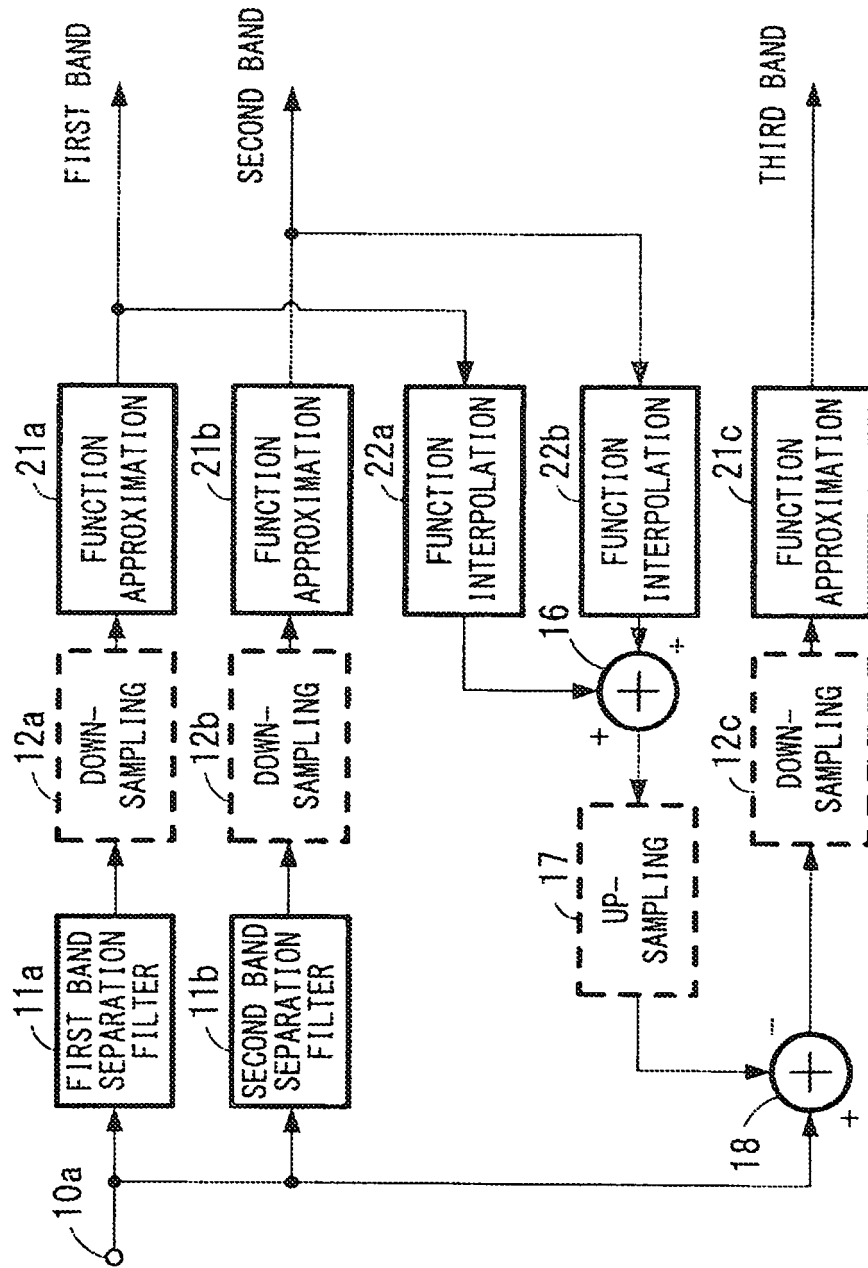

FIG. 19



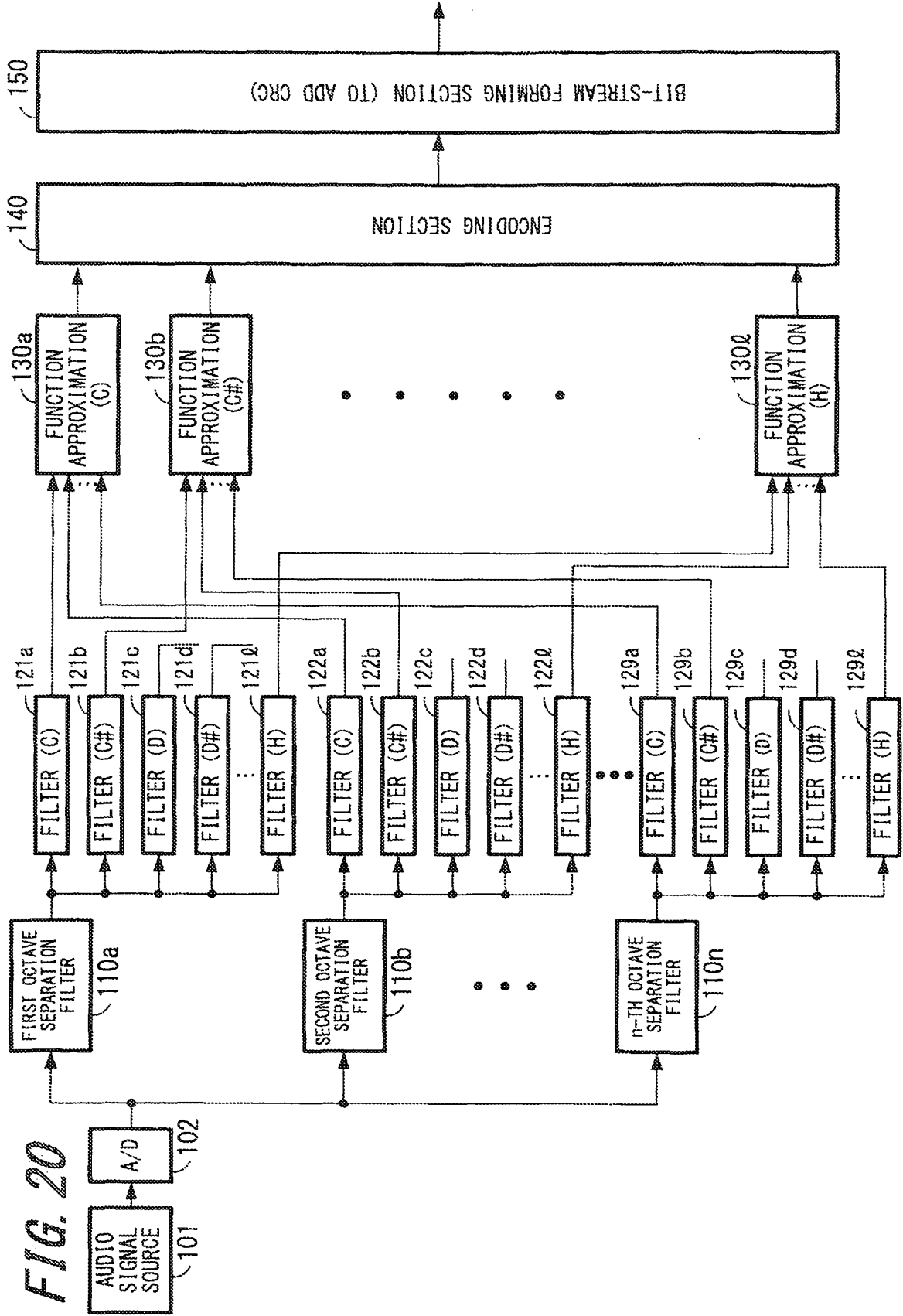

FIG. 21A

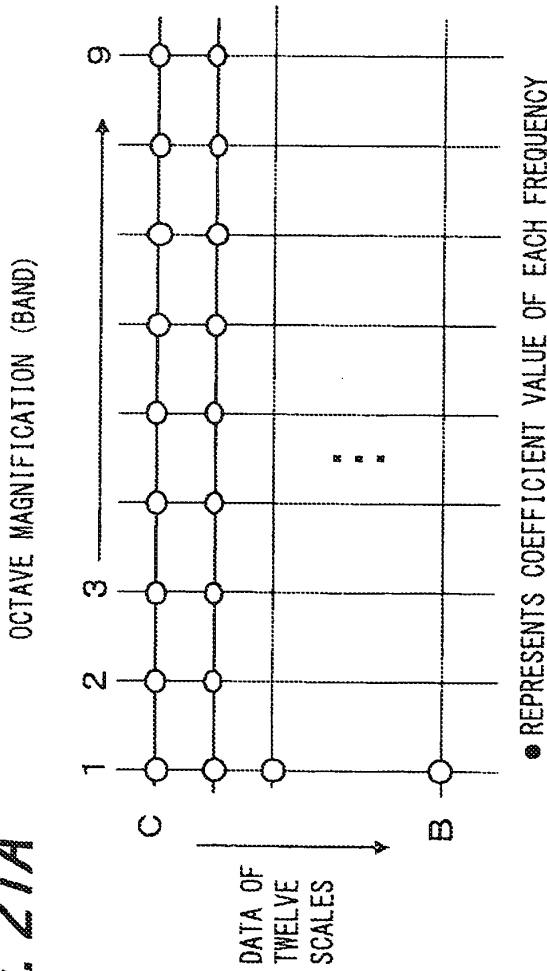

FIG. 21B

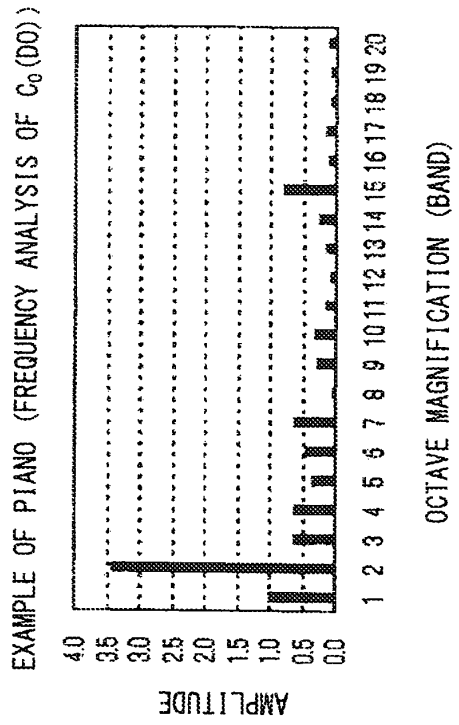

FIG. 21C

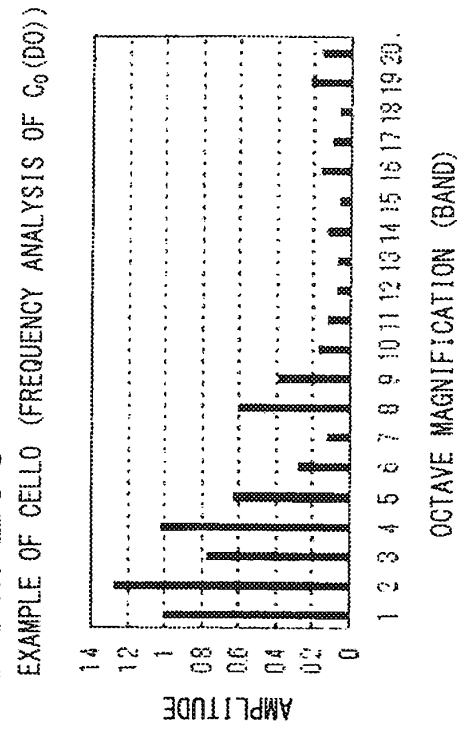

FIG. 22

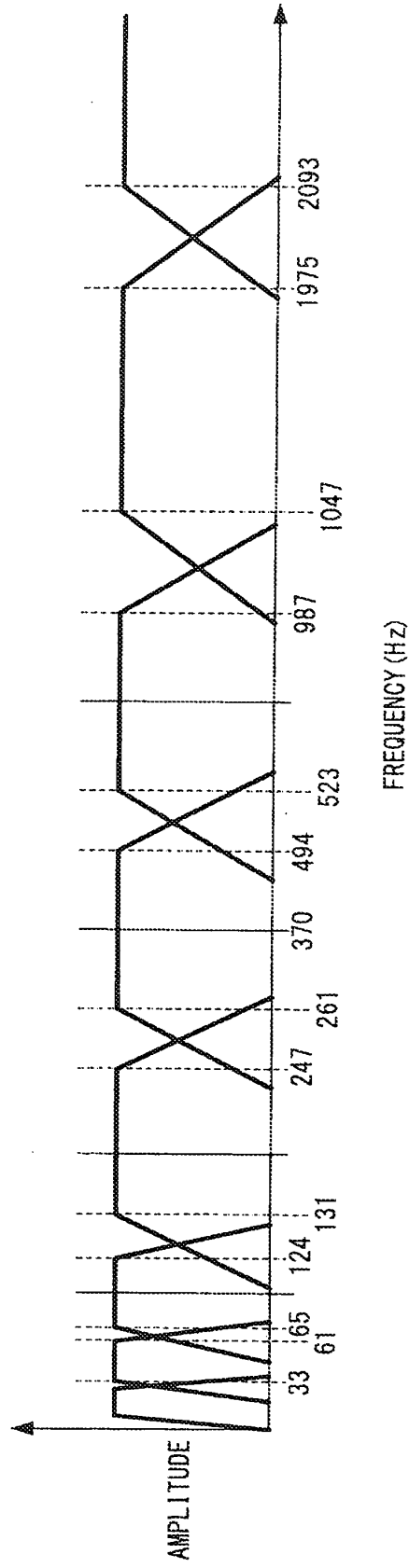

FIG. 23

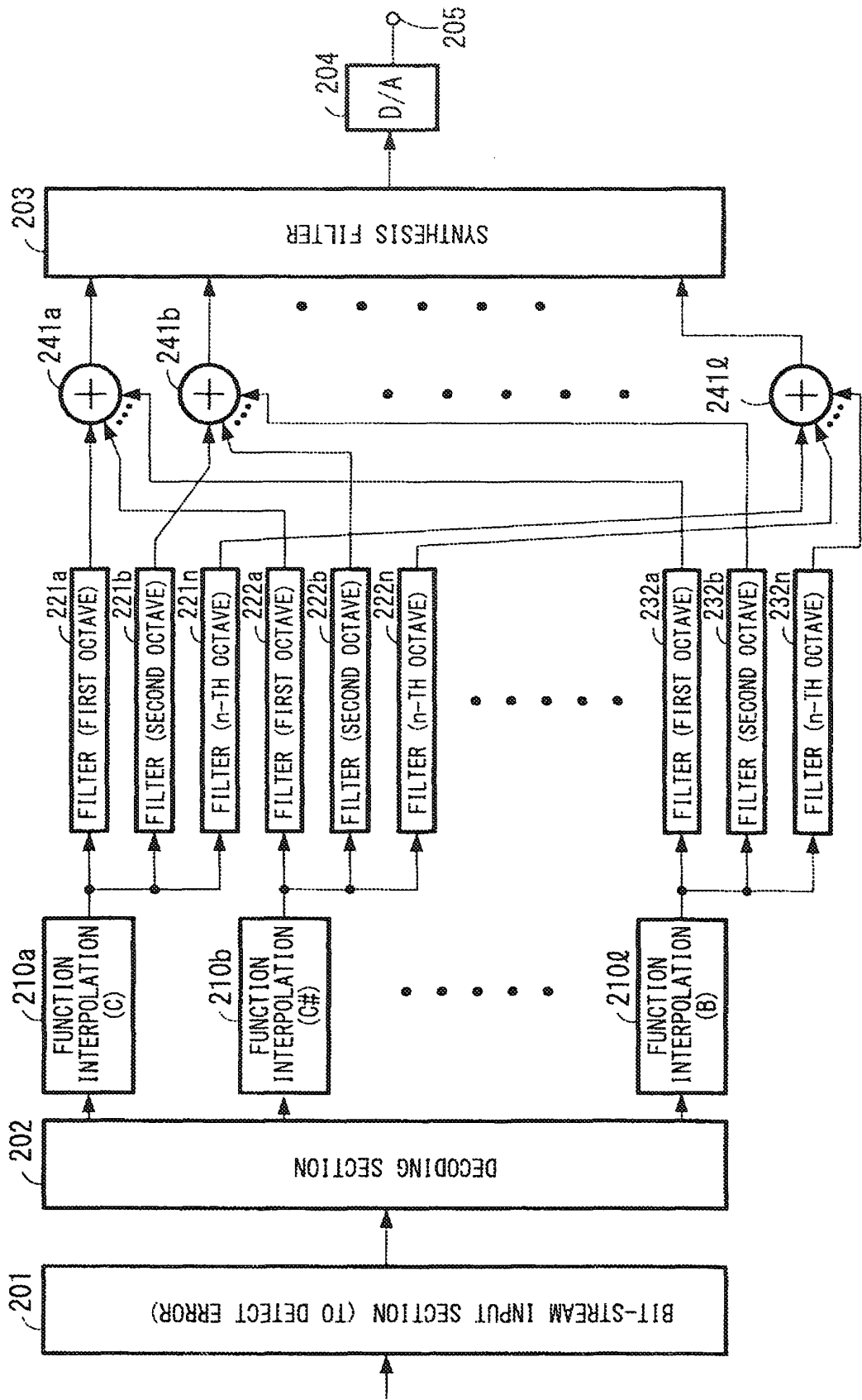
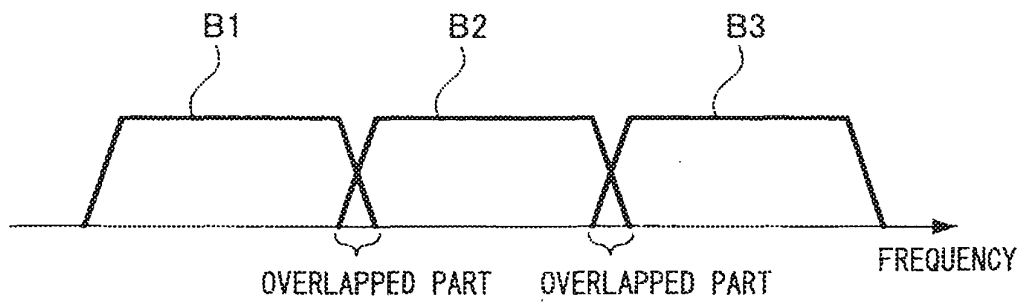

FIG. 24



REFERENCES CITED IN THE DESCRIPTION

This list of references cited by the applicant is for the reader's convenience only. It does not form part of the European patent document. Even though great care has been taken in compiling the references, errors or omissions cannot be excluded and the EPO disclaims all liability in this regard.

Patent documents cited in the description

- WO 2005004113 A [0004]

Non-patent literature cited in the description

- **VELDHUIS R N J et al.** Subband coding of digital audio signals without loss of quality. *INTERNATIONAL CONFERENCE ACOUSTICS, SPEECH, AND SIGNAL PROCESSING (ICASSP)*, 23 May 1989, 2009-2012 [0005]