



US 20070121690A1

(19) **United States**

(12) **Patent Application Publication**

Fujii et al.

(10) **Pub. No.: US 2007/0121690 A1**

(43) **Pub. Date: May 31, 2007**

(54) **HIGHLY EFFICIENT GALLIUM NITRIDE
BASED LIGHT EMITTING DIODES VIA
SURFACE ROUGHENING**

(86) PCT No.: **PCT/US03/39211**

§ 371(c)(1),
(2), (4) Date: **Jun. 5, 2006**

(76) Inventors: **Tetsuo Fujii**, Santa Barbara, CA (US);
Yan Gao, Santa Barbara, CA (US);
Evelyn L. Hu, Santa Barbara, CA (US);
Shuji Nakamura, Santa Barbara, CA
(US)

Publication Classification

(51) **Int. Cl.**
H01S 5/00 (2006.01)
(52) **U.S. Cl.** **372/43.01**
(57) **ABSTRACT**

Correspondence Address:
GATES & COOPER LLP
HOWARD HUGHES CENTER
6701 CENTER DRIVE WEST, SUITE 1050
LOS ANGELES, CA 90045 (US)

A gallium nitride (GaN) based light emitting diode (LED), wherein light is extracted through a nitrogen face (N-face) (42) of the LED and a surface of the N-face (42) is roughened into one or more hexagonal shaped cones. The roughened surface reduces light reflections occurring repeatedly inside the LED, and thus extracts more light out of the LED. The surface of the N-face (42) is roughened by an anisotropic etching, which may comprise a dry etching or a photo-enhanced chemical (PEC) etching.

(21) Appl. No.: **10/581,940**

(22) PCT Filed: **Dec. 9, 2003**

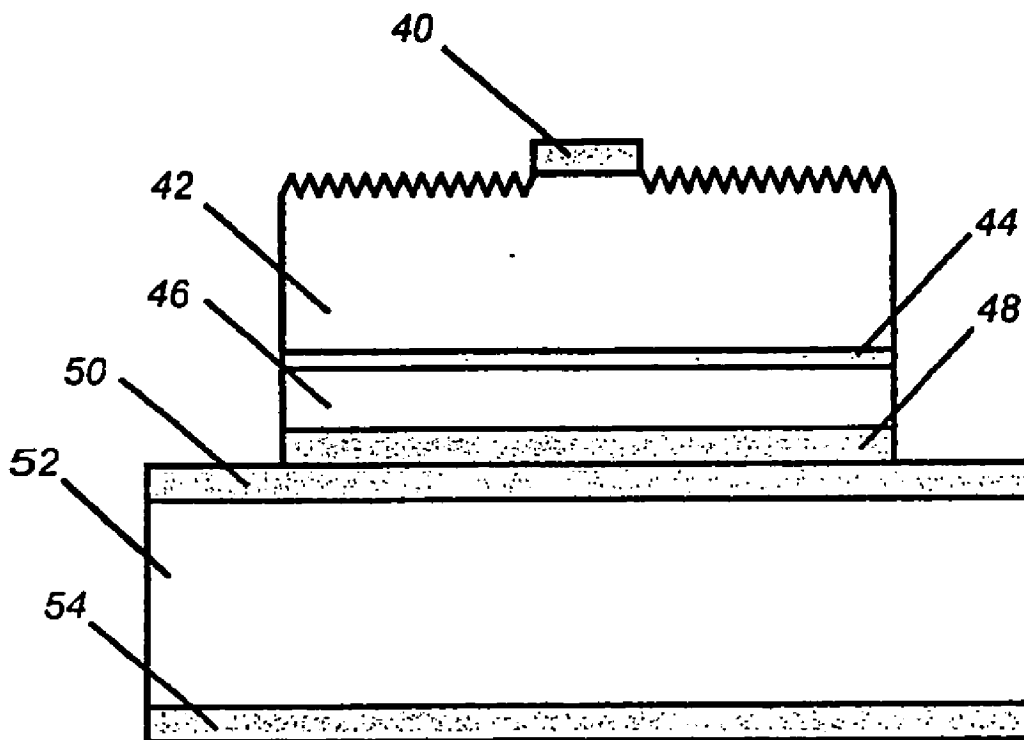

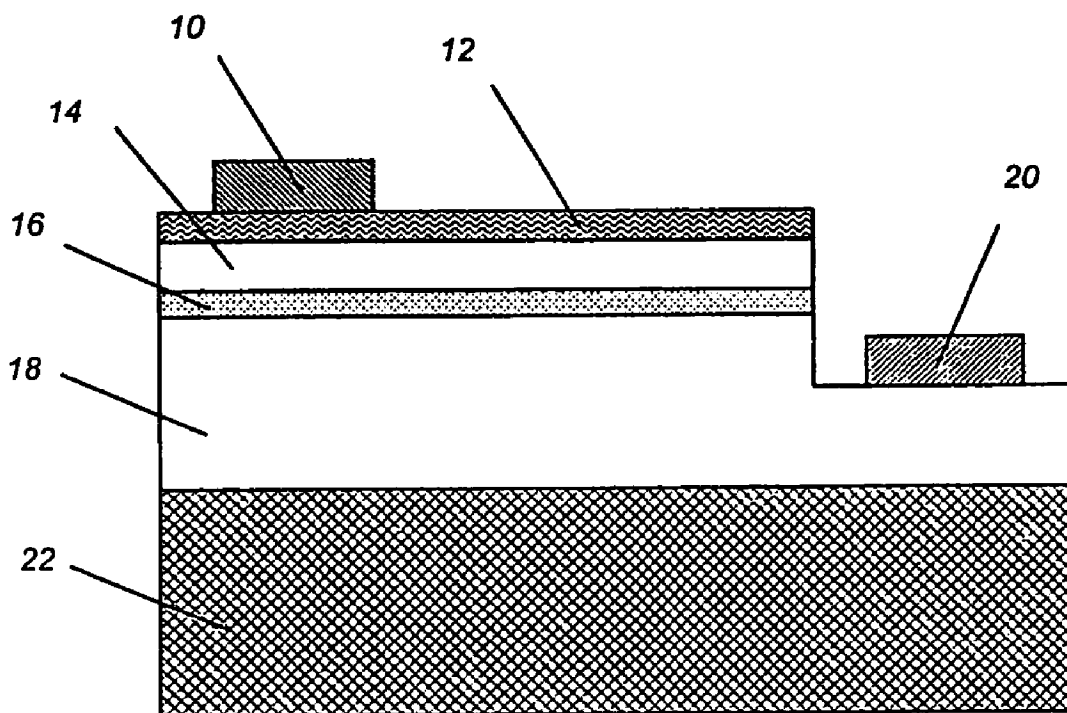

FIG. 1

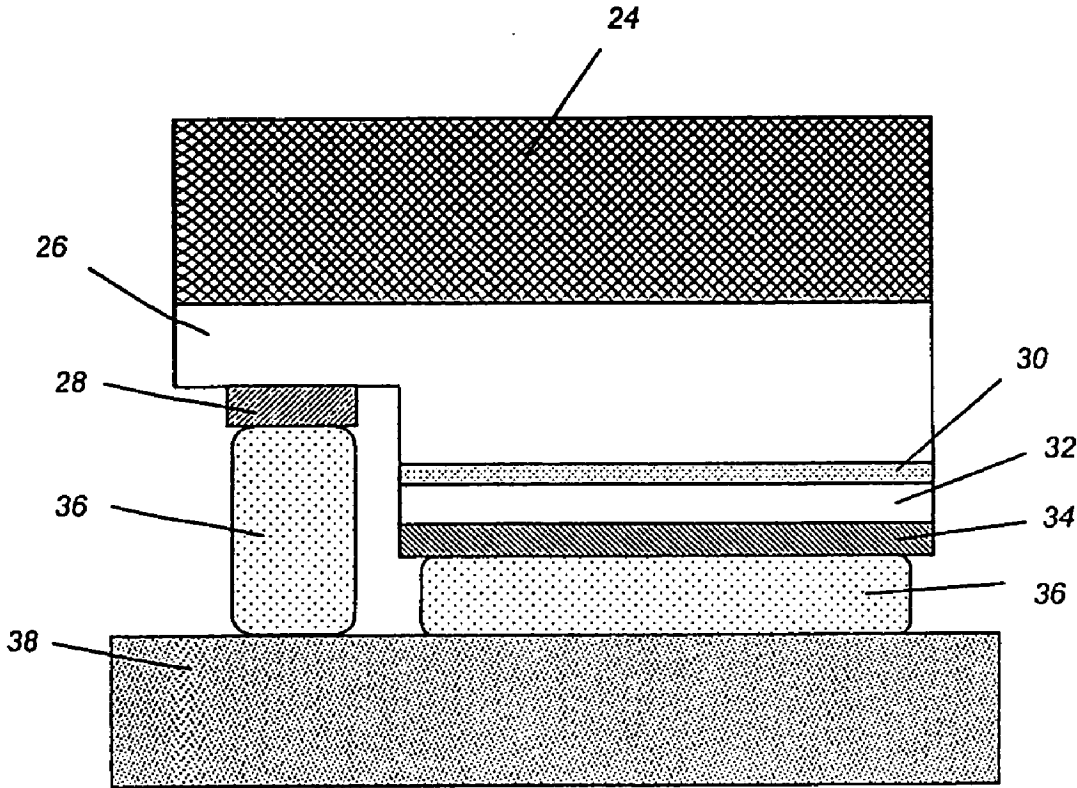

FIG. 2

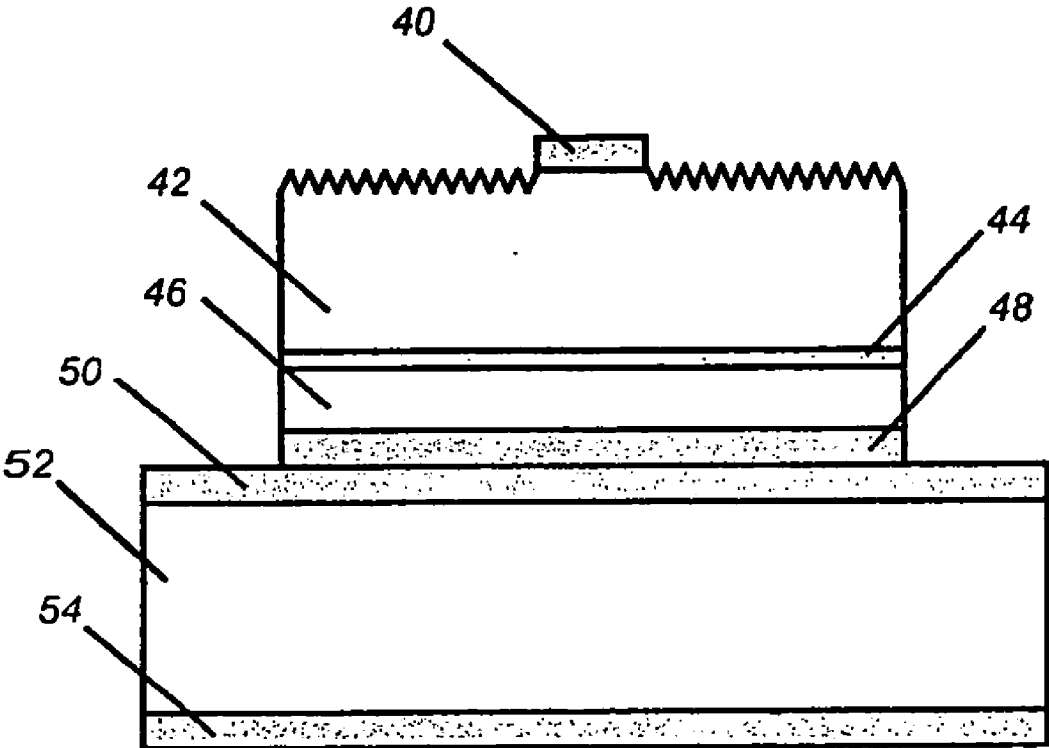

FIG. 3

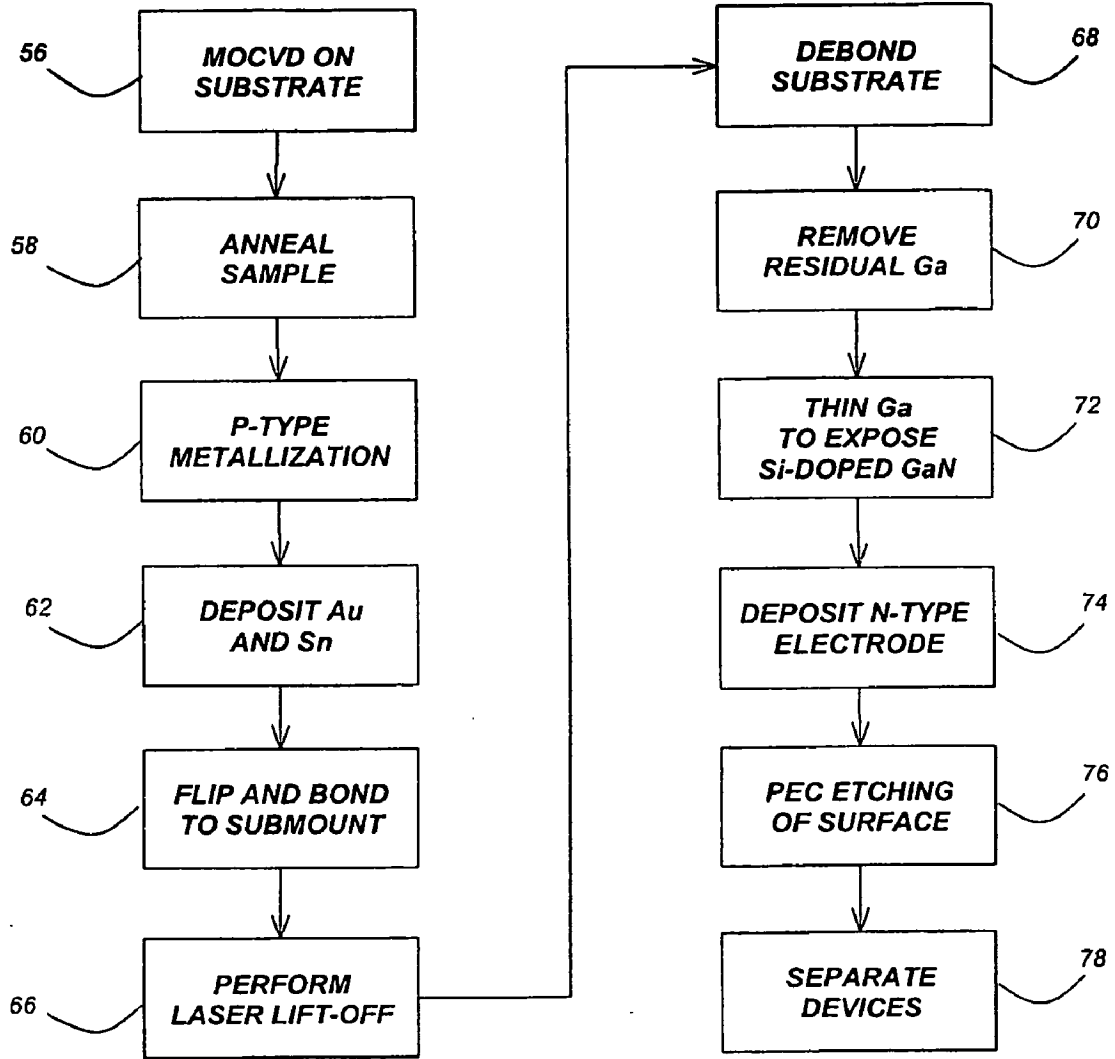

FIG. 4

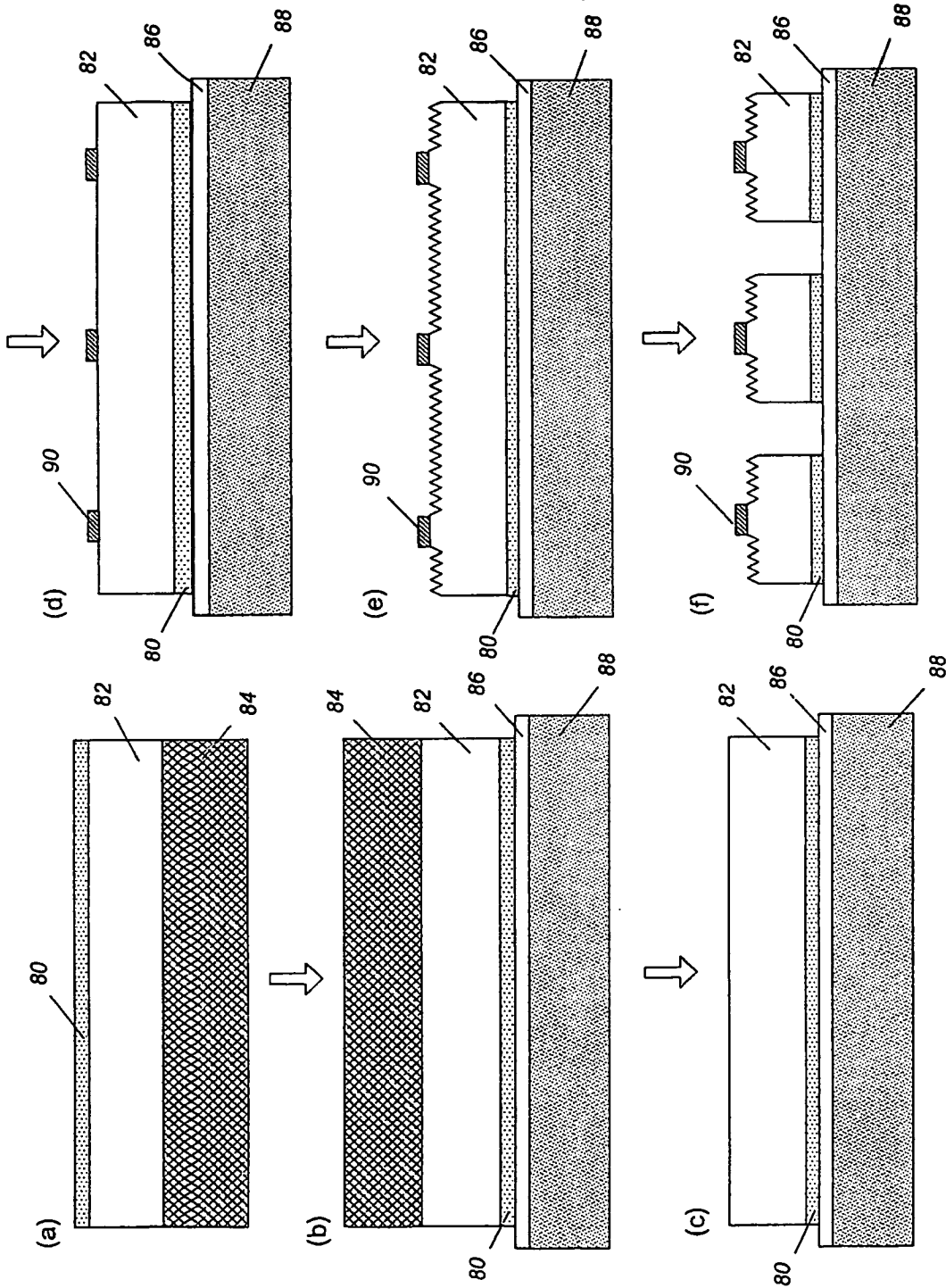

FIG. 5

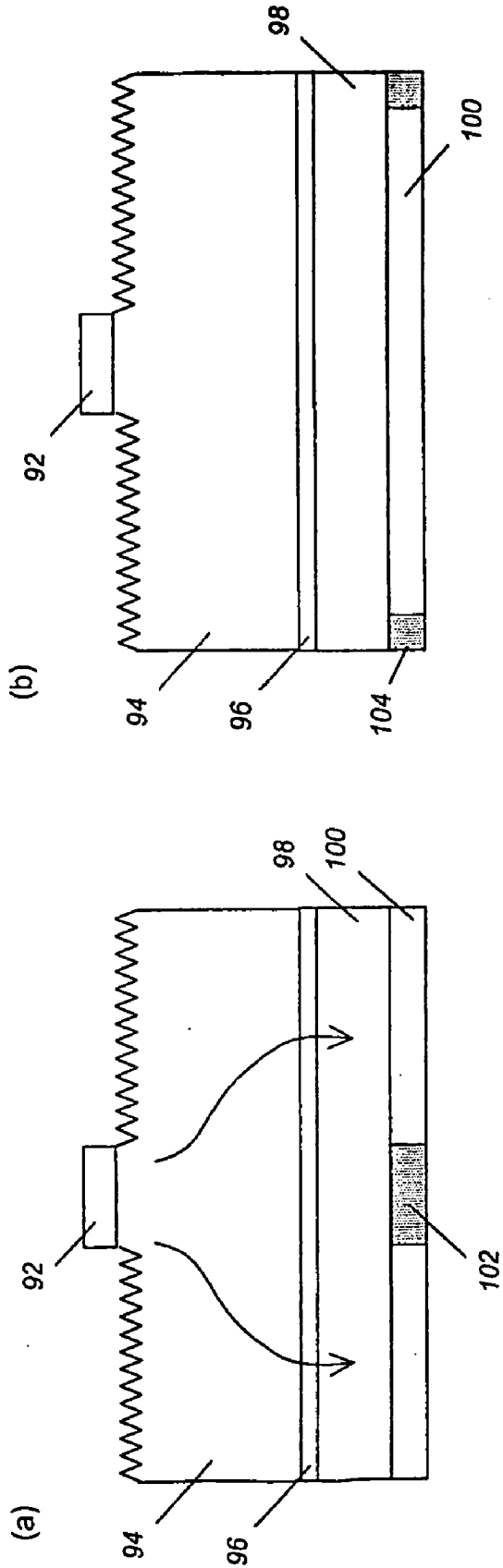

FIG. 6

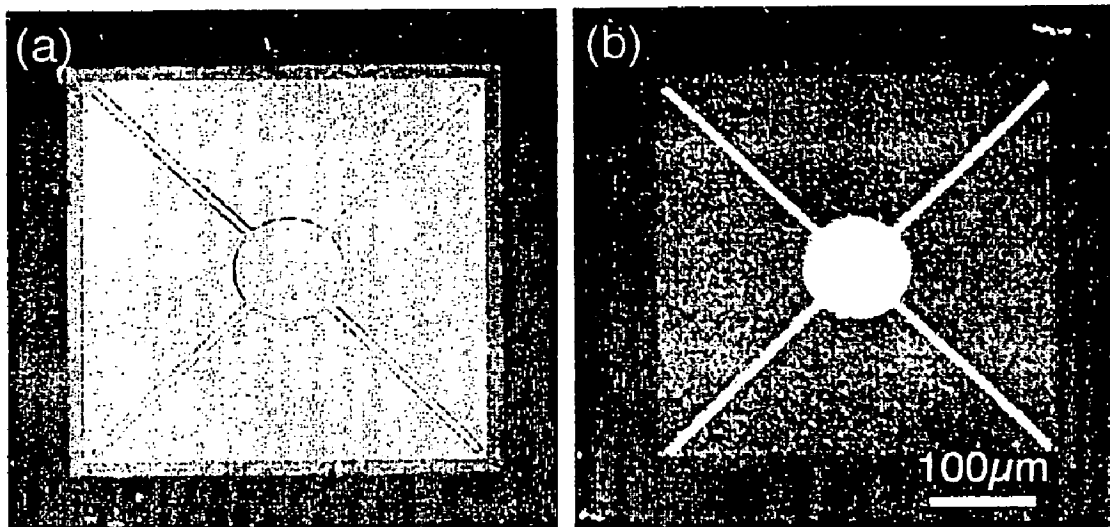

FIG. 7

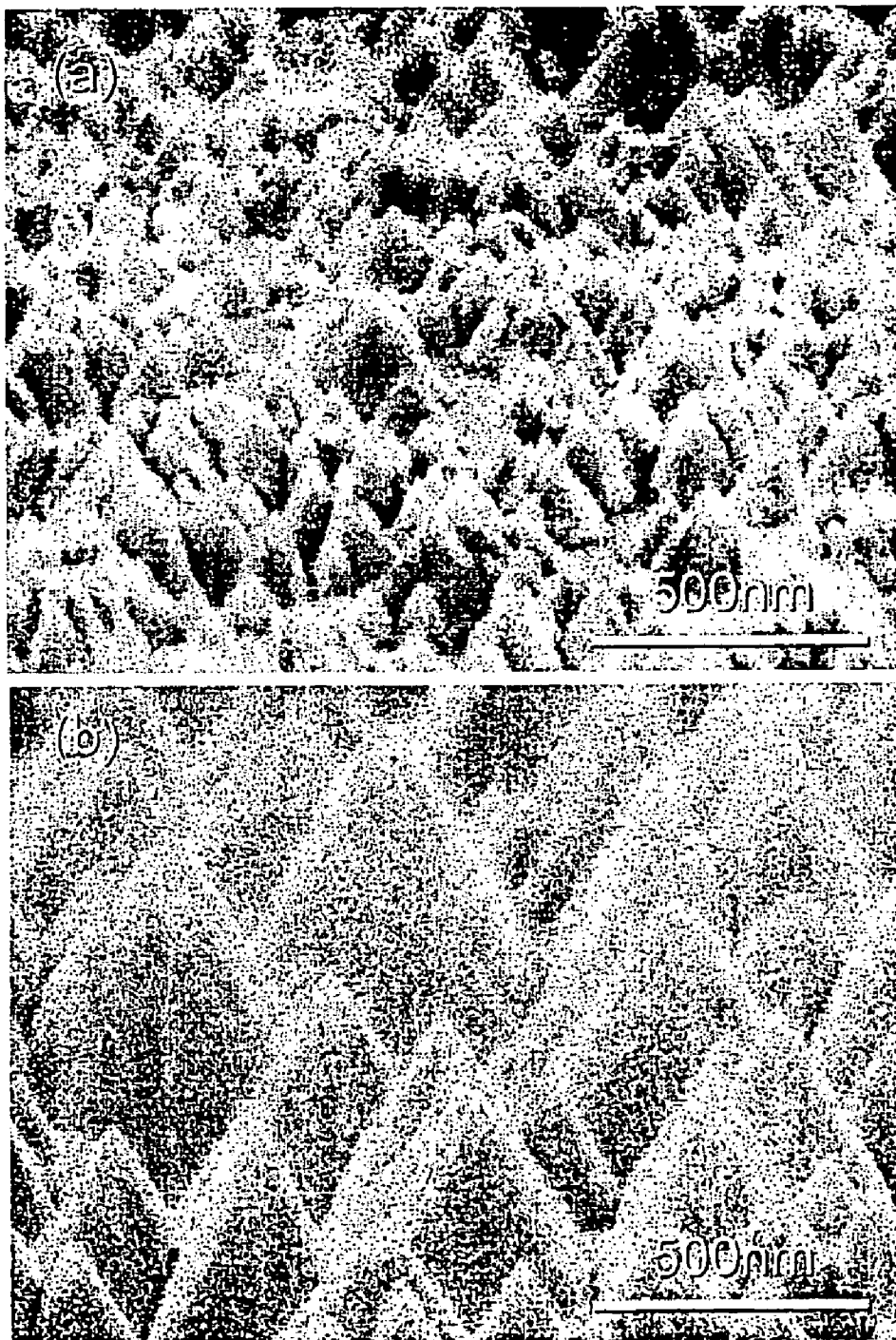

FIG. 8

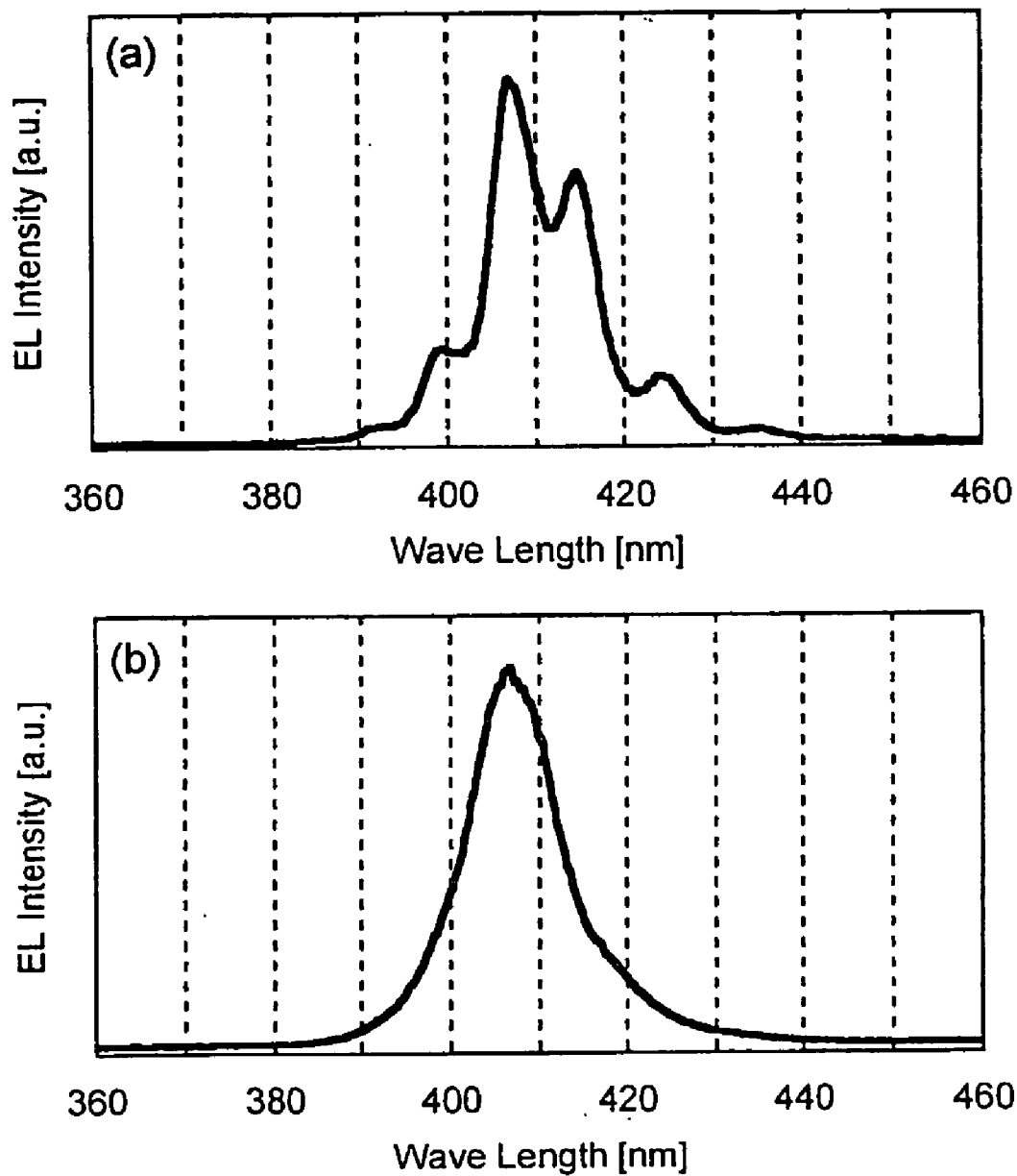

FIG. 9

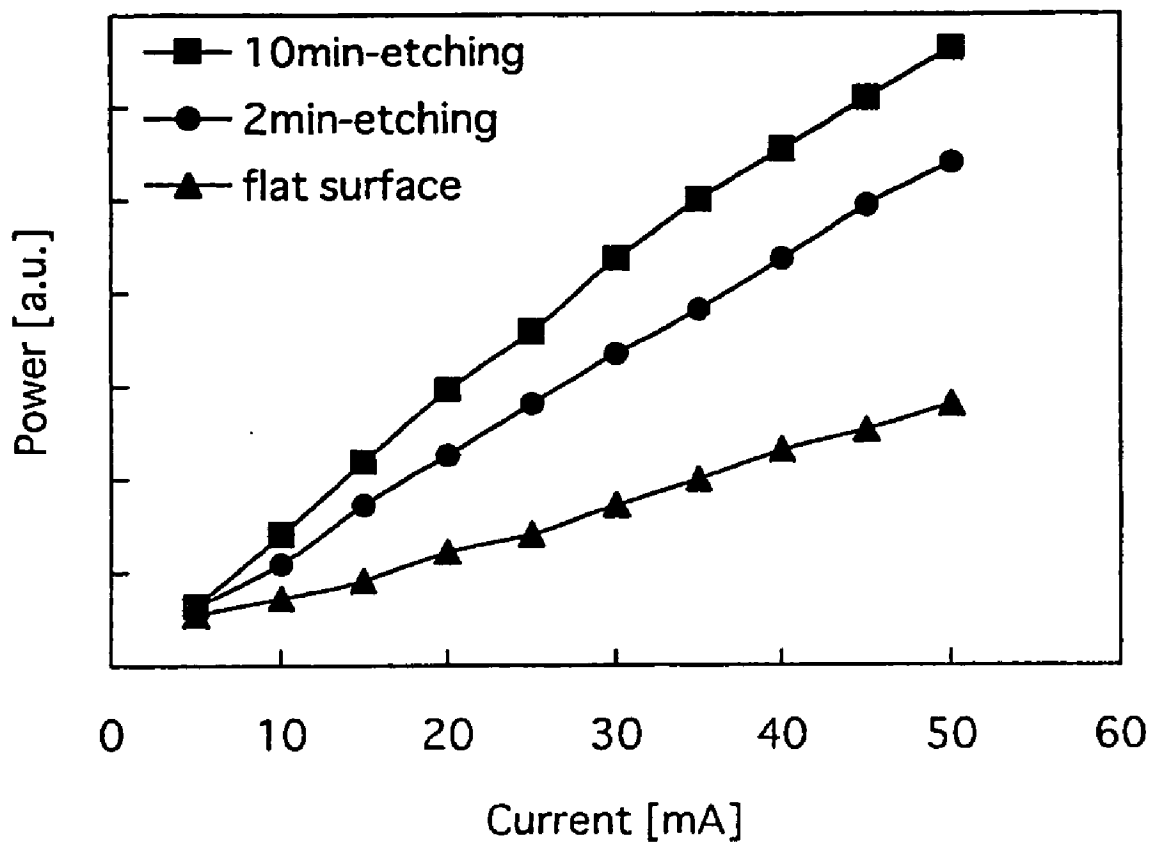

FIG. 10

HIGHLY EFFICIENT GALLIUM NITRIDE BASED LIGHT EMITTING DIODES VIA SURFACE ROUGHENING

1. FIELD OF THE INVENTION

[0001] The invention is related to light emitting diodes, and more particularly, to highly efficient gallium nitride based light emitting diodes via surface roughening.

2. DESCRIPTION OF THE RELATED ART

[0002] (Note: This application references a number of different publications as indicated throughout the specification by one or more reference numbers. A list of these different publications ordered according to these reference numbers can be found below in the section entitled "References." Each of these publications is incorporated by reference herein.)

[0003] Gallium nitride (GaN) based wide band gap semiconductor light emitting diodes (LEDs) have been available for about 10 years. The progress of LED development has brought about great changes in LED technology, with the realization of full-color LED displays, LED traffic signals, white LEDs and so on

[0004] Recently, high-efficiency white LEDs have gained much interest as possible replacements for fluorescent lamps. Specifically, the efficiency of white LEDs (74 lm/W) [1] is approaching that of ordinary fluorescent lamps (75 lm/W). Nonetheless, more improvement in efficiency is desirable.

[0005] There are two principle approaches for improving LED efficiency. The first approach is increasing the internal quantum efficiency (η_i), which is determined by crystal quality and epitaxial layer structure while the second approach is increasing the light extraction efficiency ($\eta_{\text{extrac-tion}}$).

[0006] Increasing the internal quantum efficiency cannot readily be done. A typical η_i value for blue LEDs is more than 70% [2] and an ultraviolet (UV) LED grown on a low-dislocation GaN substrate has recently exhibited an η_i of about 80% [3]. There is little room for improvement of these values.

[0007] On the other hand, there is plenty of room for improving the light extraction efficiency. A number of issues may be addressed in eliminating the internal loss of light, including: high reflective mirror, low reflection surface such as roughened surface, highly thermal dispersion structure, etc.

[0008] For example, considering the refractive indices of GaN ($n \approx 2.5$) [4] and air, the critical angle for the light escape cone is about 23° . Assuming that light emitted from sidewalls and the backside is neglected, it is expected that approximately only 4% of the internal light can be extracted. The light outside the escape cone is reflected into the substrate and is reflected repeatedly or absorbed by active layers or electrodes, unless it escapes through the sidewalls.

[0009] The LED structure affects how much light is emitted. The impact of LED structure on light extraction efficiency is best described by example. The following examples describe several types of LED structures.

[0010] FIG. 1 is a schematic cross-section of a conventional LED structure, which includes a p-type pad electrode 10, semitransparent electrode 12, p-type layer 14, active region 16, n-type layer 18, n-type electrode 20, and substrate 22. Because GaN is usually grown on an insulator substrate, such as sapphire, p-type and n-type electrodes 10, 20 need to be fabricated on the same plane and the resulting device structure of the electrodes 10, 20 imposes a lateral current flow. Due to the high resistivity of p-type GaN, a thin metal film is employed as a semitransparent electrode 12 for current spreading on the p-type GaN. It is desirable that the transparency of the semitransparent electrode 12 should be 100%; however, its value for the thin metal electrodes used in GaN based LEDs is 70% at most. Moreover, the pad electrode 10 should be formed for wire bonding, which obscures the light emitted from the inside of the LED; consequently, the extraction efficiency is expected to be quite low.

[0011] FIG. 2 is a schematic cross-section of a flip-chip type LED structure, which includes a transparent sapphire substrate 24, n-type layer 26, n-type electrode 28, active region 30, p-type layer 32, p-type electrode 34, solder 36, and host submount 38. In order to improve the external efficiency, light can be extracted through the transparent sapphire substrate 24 of the flip-chip type LED structure. This method has an advantage over conventional LEDs with respect to a reduction of the light absorption by the thin metal film and the pad electrode. However, most of the light emitted from the active region would be reflected at the interface between the substrate 24 and n-type layer 26, and the interface between the substrate 24 and the air.

[0012] A method that allows for GaN film detachment from a sapphire substrate is called "laser lift off" (LLO) technique. By applying this method to flip-chip type GaN based LEDs, sapphire substrate-free GaN LEDs can be realized. Assuming that the resulting GaN surface is worked into a non-planar orientation, a significant improvement of the extraction efficiency is expected.

[0013] Another approach to increasing extraction efficiency is to roughen the LED's surface [5], which discourages internal light reflection and scatters the light upward. However, surface roughened LEDs have been mentioned only in the context of the gallium phosphide (GaP) family of materials, because GaN is very durable material and an ordinary wet etching method does not have much effect. Thus, although the idea of roughening the semiconductor surface for the sake of scattering light was first considered in the 1970's, it has been believed to be difficult and costly for this kind of LED structure to be produced.

[0014] However, as noted above, typical GaN-based LEDs are comprised of a thin p-GaN/active layer/n-GaN film on a sapphire or silicon carbide (SiC) substrate. Although producing a roughened surface requires a certain GaN layer thickness [6], growing thick p-GaN is not desirable due to the relatively high resistivity of p-GaN, which demands a semi-transparency contact on the p-GaN surface if the light is extracted through the p-GaN, and some treatments such as dry etching [7] for roughening surfaces might cause electrical deterioration. Growing a p-side down structure by metalorganic chemical vapor deposition (MOCVD) is also undesirable, because of the magnesium (Mg) memory effect [8], which deteriorates the active layer.

[0015] Recently, a laser lift off (LLO) method has been used to detach a sapphire substrate from a GaN film grown on the substrate [9-11]. Further, LLO has been used to fabricate GaN-based LEDs [12, 13]. However, there was no reference to the effect of this technique on surface morphology or extraction efficiency.

[0016] On the other hand, in the present invention, utilizing flip-chip technology [14] and the LLO method, a substrate-free nitrogen (N) side-up GaN-based LED structure can be made. Thereafter, an anisotropic etching process can be used to roughen the surface of the N-side-up GaN-based LED. This results in a hexagonal "cone-like" surface, which is beneficial for light extraction. Extraction efficiency of an optimally roughened surface LED shows an increase by more than 100% compared to an LED before roughening.

[0017] Note that, for some time, GaN has been believed to be difficult to anisotropically etch. This is true because GaN is a chemically stable material compared with other semiconductor materials. The use of dry etching to make a textured surface is possible, but requires extra processing, such as photolithography, and it is impossible to make a fine cone-like surface on the GaN.

[0018] When photo-enhanced chemical (PEC) etching is used on gallium face (Ga-face) GaN, small pits are formed on the surface. This is in contrast to PEC etching of nitrogen face (N-face) GaN, which results in distinct cone-like features. Although there are a few reports dealing with GaN-based LEDs fabricated using the LLO technique, the present invention fabricates cone-like structures on the N-face GaN surface of the GaN based LED using an anisotropic etching method.

SUMMARY OF THE INVENTION

[0019] The present invention describes a gallium nitride (GaN) based light emitting diode (LED), wherein light is extracted through a nitrogen face (N-face) of the LED and a surface of the N-face is roughened into one or more hexagonal shaped cones. The roughened surface reduces light reflections occurring repeatedly inside the LED, and thus extracts more light out of the LED.

[0020] The surface of the N-face is roughened by an anisotropic etching. The anisotropic etching may comprise a dry etching or a photo-enhanced chemical (PEC) etching.

[0021] In one embodiment, the N-face GaN is prepared by a laser lift off (LLO) technique. In another embodiment, the LED is grown on a c-plane GaN wafer, a p-type layer's surface is a gallium face (Ga-face), and the n-type layer's surface is a nitrogen face (N-face).

BRIEF DESCRIPTION OF THE DRAWINGS

[0022] Referring now to the drawings in which like reference numbers represent corresponding parts throughout:

[0023] FIG. 1 is a schematic cross-section of a conventional LED structure;

[0024] FIG. 2 is a schematic cross-section of a flip-chip type LED structure;

[0025] FIG. 3 is a schematic of a surface roughened LED;

[0026] FIG. 4 is a flowchart that illustrates the processing steps used in the preferred embodiment of the present invention;

[0027] FIGS. 5(a)-(f) further illustrate the fabrication steps for the LEDs with surface roughening;

[0028] FIG. 6(a) shows an LED with a current-blocking layer, while FIG. 6(b) shows an LED with a current-confining frame;

[0029] FIGS. 7(a) and 7(b) are plan-view micrographs of an LLO-LED with a cross-shaped n-electrode;

[0030] FIGS. 8(a) and 8(b) are scanning electron micrograph (SEM) images of the N-face of GaN after PEC etching for different etching times;

[0031] FIGS. 9(a) and 9(b) show an electroluminescence (EL) spectra from a flat-surface LED and a roughened-surface LED, respectively; and

[0032] FIG. 10 is a graph of upward EL output power vs. DC injection current (I-I) characteristics for the LEDs with different etching times at room temperature.

DETAILED DESCRIPTION OF THE INVENTION

[0033] In the following description of the preferred embodiment, reference is made to the accompanying drawings which form a part hereof, and in which is shown by way of illustration a specific embodiment in which the invention may be practiced. It is to be understood that other embodiments may be utilized and structural changes may be made without departing from the scope of the present invention.

[0034] Overview

[0035] The present invention provides a means of increasing the extraction efficiency by roughening the surface of GaN based LEDs. Specifically, applying an anisotropic PEC etching method to an N-face c-plane GaN surface results in the fabrication of cone-shaped surface features. This roughened surface reduces light reflections occurring repeatedly inside the LED, and thus extracts more light out of the LED. Moreover, the method of the present invention is simple, repeatable and should not damage the material, in contrast to other methods of surface roughening that may compromise the material's quality, all of which renders the present invention more suitable for manufacturing LEDs.

[0036] LED Structure

[0037] FIG. 3 is a schematic of a surface roughened LED, which includes an n-type electrode 40, n-type layer 42, active region 44, p-type layer 46 and p-type electrode 48 which has been flip-chip bonded via a solder layer 50 to a silicon (Si) submount 52 that includes an n-type electrode 54. The n-type layer 42, active region 44 and p-type layer 46 are comprised of a (B, Al, Ga, In) N alloy. A dry or PEC etching method is used to roughen the surface of the n-type layer 42. Appropriate conditions, such as plasma chemistries and plasma power for dry etching, and electrolytes and lamp power for PEC etching, need to be set so that a desirable surface can be obtained. It is important that this GaN based LED should be grown along its c-axis and this n-type GaN surface should be N-face because anisotropic etching can be observed on N-face GaN much more readily than Ga-face GaN.

[0038] Note that c-plane GaN is the structure where the plane that contains only Ga atoms and the plane that contains only N atoms are piled or stacked up alternately. If one

surface is Ga-face, then the opposing surface is N-face. Due to the fact that Ga-face c-plane GaN is generally preferred from the point of view of crystal growth and device performance, N-face GaN needs to be prepared by the LLO technique, or alternatively, the LED structure could be grown on the c-plane bulk GaN wafer.

[0039] The light emitted from the active region **44** toward the roughened n-type GaN surface **42** is scattered by the surface, which does not reflect the light back to the active region. It is desired that the p-type electrode **48** have a property of high reflection to decrease light absorption and to increase light reflection toward the n-type GaN surface **42**. In experimental results, it has been determined that the present invention increases the upward light output power for the LED with a roughened surface two or three times as compared with an LED with a flat surface.

[0040] Processing Steps

[0041] FIG. 4 is a flowchart that illustrates the processing steps used in the preferred embodiment of the present invention.

[0042] Block **56** represents the step of growing Ga-face epitaxial layers on a c-plane sapphire substrate by MOCVD, thereby creating a sample.

[0043] Block **58** represents the step of annealing the sample for p-type activation, after the MOCVD.

[0044] Block **60** represents the step of performing a p-type metallization process on the sample, including, but not limited to, silver (Ag) or aluminum (Al), to create a highly reflective p-GaN contact.

[0045] Block **62** represents the step of depositing thick gold (Au) layers on the sample, followed by tin (Sn) layers as a solder metal by Sn evaporation in a thermal evaporator.

[0046] Block **64** represents the step of flipping the sample and bonding it to an Au-coated Si substrate/submount at a temperature above 280° C., wherein an Au/Sn alloy forms that contributions to the adhesion of the sample to the Si substrate.

[0047] Block **66** represents the step of performing an LLO process by irradiating the transparent sapphire substrate of the sample using a krypton fluoride (KrF) excimer laser light (248 nm) through the backside of the sapphire substrate, resulting in local decomposition of the GaN at the GaN/sapphire substrate interface. Specifically, by rastering the KrF excimer laser spot over the sample, the GaN-based LED membrane is transferred to the Si substrate/submount.

[0048] Block **68** represents the step of debonding the sapphire substrate from the sample, after rastering the KrF laser over the sample.

[0049] Block **70** represents the step of removing any residual Ga droplets on the detached GaN surface of the sample using an hydrochloride (HCl) solution.

[0050] Block **72** represents the step of thinning the transferred GaN until the Si-doped N-face GaN is exposed on the sample.

[0051] Block **74** represents the step of depositing a titanium/aluminum/titanium/gold (Ti/Al/Ti/Au) electrode as an n-type contact or electrode on the exposed N-face GaN of the sample.

[0052] Block **76** represents the step of PEC etching by immersing the sample in an electrolyte solution of potassium hydroxide (KOH) and irradiating the N-face GaN surface using a xenon/mercury (Xe/Hg) lamp, in such a way that the top surface is roughened. The details of PEC etching are described in [15].

[0053] Block **78** represents the step of separating each device on the Si substrate of the sample using a dry etching, dicing or cleaving method.

[0054] FIGS. 5(a)-(f) further illustrate the fabrication steps for the LEDs with surface roughening, wherein the LED structure includes a p-type electrode **80**, GaN-based LED membrane **82**, sapphire substrate **84**, solder metal **86**, submount (carrier) **88** and n-type electrode **90**. Specifically, FIG. 5(a) shows the results after the p-type electrode **80** deposition, FIG. 5(b) shows the results after the LED is bonded onto the host submount **88**, FIG. 5(c) shows the results after the sapphire substrate **84** removal by LLO, FIG. 5(d) shows the results after n-type electrode **90** deposition, FIG. 5(e) shows the results after the roughening of the GaN surface **82**, and FIG. 5(f) shows the results after device isolation.

[0055] Possible Modifications

[0056] Although a basic structure has been described above, a number of modifications and variations are possible.

[0057] FIG. 6(a) shows an LED with a current-blocking layer, while FIG. 6(b) shows an LED with a current-confining frame, wherein the LEDs include an n-type electrode **92**, n-type layer **94**, active layer **96**, p-type layer **98**, p-type electrode **100**, current-blocking layer **102**, and current confining frame **104**.

[0058] In FIG. 6(a), the LED has a current-blocking layer **102** aligned under the n-type electrode **92**. This current-blocking layer **102** keeps the current from concentrating below the n-type electrode **92** so that absorption of light emission under the electrode **92** can be avoided and the extraction efficiency can be increased. It is suitable that an insulator such as SiO₂ is located on the p-GaN layer **98** because the current spreading hardly occurs in the resistive p-GaN layer **98**.

[0059] In FIG. 6(b), the LED has a current-confining frame **104** made of an insulator. If a dry-etching or a dicing method is used to separate the devices, the sidewalls of the devices might conduct a leakage current, if the surfaces are damaged. Such leakage current decreases both the efficiency and lifetime of the LED. The current-confinement frame **104** contributes to the restraint of leakage current through the sidewalls of the LED and does not significantly decrease the emitting area, if the width of the frame is chosen appropriately.

[0060] Although an Si substrate has been described as a host submount in the LLO process, alternative substrate materials may be used to practice this invention. Although Si is cheaper and has a higher thermal conductivity than sapphire, other substrates, such as SiC, diamond, AlN, or various metals such as CuW, may be fit for use from the point of view of thermal conductivity.

[0061] At present, GaN devices can be also grown directly on SiC and Si substrate. If a GaN-based LED is grown on

SiC or Si, conventional dry etching or wet etching can remove the substrate. By utilizing a bulk GaN substrate, the LLO process can be eliminated.

[0062] Sample size is also an important point for LED fabrication. Nowadays, LEDs with a large size are attracting attention to meet demand for high-power LEDs. Even though the resistivity of the n-type GaN is lower than that of p-GaN, the size affects the n-type electrode geometry for the purpose of current spreading.

EXPERIMENTAL RESULTS

[0063] In experiments performed by the inventors, Ga-face epitaxial layers were grown on a c-plane sapphire substrate by MOCVD. The structure was comprised of 4 μm -thick undoped and Si-doped GaN layers, a 5-period GaN/InGaN multi-quantum-well (MQW), a 20 nm-thick Mg-doped $\text{Al}_{0.2}\text{Ga}_{0.8}\text{N}$ layer, and 0.3 μm -thick Mg-doped GaN. After MOCVD, the sample was annealed for p-type activation and then a p-type metallization process was performed. An Ag-based electrode was adopted as a highly reflective p-GaN contact. Thick Au was deposited on the sample followed by Sn evaporation in a thermal evaporator. The wafer was flipped and bonded to an Au-coated Si submount at a temperature of 280° C., resulting in an alloy of Au and Sn, which contributes to firm adhesion of the wafer to the submount. A KrF laser (248 nm) was used for the LLO process, in which the laser was shone through the transparent sapphire substrate, causing local decomposition of GaN at the boundary between GaN and sapphire. After rastering the KrF laser over the sample, the sapphire substrate was debonded. The remaining Ga droplets on the transferred GaN surface were removed by an HCl solution. Next, the transferred GaN was thinned until the Si-doped GaN was exposed. An n-contact was formed on the exposed N-face n-GaN and each device was divided from its neighbors by reactive ion etching (RIE). Finally, in order to roughen the top of surface, PEC etching was used. A KOH solution and Xe/Hg lamp were used as electrolyte and light source, respectively. The output power of the LED was measured with an Si-detector set at a height of 7 mm over the LED chips.

[0064] FIGS. 7(a) and 7(b) are plan-view micrographs of an LLO-LED with a cross-shaped n-electrode, wherein the LED is bonded on an Si substrate. FIG. 7(a) shows the surface before roughening and FIG. 7(b) shows the surface after roughening. Because the n-electrode blocks UV light during PEC etching, the GaN beneath it is not etched and the electrode remains on the GaN after roughening. A transparent electrode such as indium tin oxide (ITO) can be employed as a current spreading electrode.

[0065] FIGS. 8(a) and 8(b) are scanning electron micrograph (SEM) images of the N-face of GaN after PEC etching for different etching times. Notice that the PEC-etched N-face GaN surfaces include a plurality of hexagonal shaped, cones, which are distinct from the PEC-etched GaN surfaces reported by Youtsey, et al. [16]. This difference is considered to be due to the surface polarity of GaN. In comparing the 2 minute (min) etched surface of FIG. 8(a) and the 10 min etched surface of FIG. 8(b), the size of the features increases and the facets of the hexagonal cones become more defined.

[0066] The cone-shaped surface appears very effective for light extraction from the LED. Moreover, experimental

results suggest that a cone shape can extract more light. For example, the wavelength of a blue LED in a GaN crystal is about 200 nm. If the size of the cone shape is much smaller than that value, then the light might not be affected by the roughness. On the other hand, if the size of the cone shape is close to that value, the light might be scattered or diffracted.

[0067] In experimental results, it has been determined that the roughened surface is comprised of many hexagonal shaped cones that have an angle equal to or smaller than:

$$2 \sin^{-1}(n_{\text{air}}/n_s) \approx 47.2^\circ$$

for GaN, where n_{air} is a refractive index of air and n_s is a refractive index of GaN. Similarly, it has been determined that the roughened surface is comprised of many hexagonal shaped cones that have an angle equal to or smaller than:

$$2 \sin^{-1}(n_{\text{enc}}/n_s)$$

for epoxy, where n_{enc} is a refractive index of epoxy and n_s is a refractive index of GaN.

[0068] It is possible that the surface may not have to be cone shaped, and a grating structure and photonic crystal should be considered. These might be better structures for light extraction. However, the fabrication of photonic crystals requires precise design and processing, which is more costly than fabricating a cone-shaped surface roughness.

[0069] The “mirror-like” surface before PEC etching becomes discolored as the etching time increases. If a highly reflective metal is deposited on the other side of GaN film, the surface appears white; otherwise, it is darker. This is believed to be due to the light-reflection restraint at the air/GaN boundary, and if there is a highly reflective metal on the backside of the GaN, the light passing into GaN comes out again, scattering at the roughened surface.

[0070] Electroluminescence (EL) spectra from a flat-surface LED and a roughened-surface LED are shown in FIGS. 9(a) and 9(b), respectively. The measurement was performed at a forward current density of 25 A/cm² DC at room temperature (RT). The spectrum of the flat-surface LED had multi-peaked emission, as shown in FIG. 9(a), suggesting that the light emitted from the active region was interfered in the vertical GaN cavity sandwiched between mirrors made of GaN/metal and GaN/air. In contrast, as shown in FIG. 9(b), no longitudinal mode was observed on the roughened surface LED. This means that the roughened GaN/air interface scattered the light, resulting in suppression of the resonance.

[0071] FIG. 10 is a graph of upward EL output power vs. DC injection current (L-I) characteristics for the LEDs with different etching times at room temperature. These data were obtained from the same device before and after PEC etching, so that any factor causing this difference except the surface morphology could be neglected. Any L-I curves showed linear characteristics up to 50 mA. Because of the relatively higher thermal conductivity of Si than that of sapphire, these devices are advantageous for high power operation. The output power at a given current increased with increasing PEC etching time. As compared with the output power for a flat-surface LED and the 10 min etched surface LED, this roughening treatment resulted in an increase of output power by a factor of 2.3. From other measurements on different devices, the power also showed a two to three-fold increase

after the roughening process. Because a flat-surface LED tends to emit more light from the sidewalls of the LED chip than a roughened surface LED due to the lateral propagation of light, the difference of output power would be less if the total power were measured in an integrating sphere. Nevertheless this enhancement of extraction efficiency by anisotropic etching technique shows significant improvement.

[0072] In conclusion, an anisotropic etching method has been applied to a GaN-based LED for the purpose of increasing extraction efficiency. LED output test results have indicated that, presumably due to the decrease in light propagation in the GaN film, there is a relationship between a roughened appearance and extraction efficiency. Although total integrated optical power has not been measured, the largest increase in extraction efficiency was more than 100%. It is notable that the technique described herein is simple and does not require complicated processes, which indicates that it will be suitable for manufacturing GaN based-LEDs with surface roughening.

REFERENCES

[0073] The following references are incorporated by reference herein:

- [0074] 1. <http://www.cree.com/News/news175.asp>
- [0075] 2. Y. Kawakami, Y. Narukawa, K. Omae, S. Fujita, and S. Nakamura, *Phys. Stat. Sol. (a)* 178, 331 (2000).
- [0076] 3. T. Nishida, H. Saito, and N. Kobayashi, *Appl. Phys. Lett.* 79, 711(2001).
- [0077] 4. A. Billeb, W. Grieshaber, D. Stocker, E. F. Schubert, R. F. Karlicek, Jr., *Appl. Phys. Lett.* 70, 2790 (1997).
- [0078] 5. A. A. Bergh, M. Hill, R. H. Saul, and S. Plains, U.S. Pat. No. 3,739,217 (1973), entitled "Surface Roughening Of Electroluminescent Diodes."
- [0079] 6. Chul Huh et al., *Appl. Phys. Lett.* 93, 9383 (2003).
- [0080] 7. X. A. Cao, S. J. Pearton, A. P. Zhang, G. T. Dang, F. Ren, R. J. Shul, L. Zhang, R. Hickman, and J. M. Van Hove, *Appl. Phys. Lett.* 75, 2569 (1999).
- [0081] 8. Y. Ohba and A. Hatano, *J. Crystal. Growth* 145, 214 (1994).
- [0082] 9. W. S. Wong, T. Sands, N. W. Cheung, M. Kneissl, D. P. Bour, P. Mei, L. T. Romano, and N. M. Johnson, *Appl. Phys. Lett.* 72, 1999 (1998).
- [0083] 10. P. R. Tavernier and D. R. Clarke, *J. Appl. Phys.* 89, 1527 (2001).
- [0084] 11. C. F. Chu, C. C. Yu, H. C. Cheng, C. F. Lin, and S. C. Wang, *Jpn. J. Appl. Phys.* 42, L147 (2003).
- [0085] 12. W. S. Wong, T. Sands, N. W. Cheung, M. Kneissl, D. P. Bour, P. Mei, L. T. Romano, N. M. Johnson, "Fabrication of thin-film InGaN light-emitting diode membranes by laser lift off," *Appl. Phys. Lett.*, 75 (10) 1360 (1999).
- [0086] 13. W. S. Wong, T. Sands, N. W. Cheung, M. Kneissl, D. P. Bour, P. Mei, L. T. Romano, N. M. Johnson,

"InXGal-XN light emitting diodes on Si substrates fabricated by Pd-In metal bonding and laser lift-off," *Appl. Phys. Lett.*, 77 (18) 2822 (2000).

[0087] 14. J. J. Wierer, D. A. Steigerwald, M. R. Krames, J. J. O'Shea, M. J. Ludowise, N. F. Gardner, R. S. Kern, and S. A. Stockman, *Appl. Phys. Lett.* 78, 3379 (2001).

[0088] 15. M. S. Minsky, M. White, and E. L. Hu, *Appl. Phys. Lett.* 68, 1531 (1996).

[0089] 16. C. Youtsey, L. T. Romano, and I. Adesida, *Appl. Phys. Lett.* 73, 797 (1998).

CONCLUSION

[0090] This concludes the description of the preferred embodiment of the present invention. The following describes some alternative embodiments for accomplishing the present invention.

[0091] A number of different growth methods other than MOCVD could be used in the present invention.

[0092] In addition, substrates other than sapphire or silicon carbide could be employed.

[0093] Also, different LED structures may be created. For example, resonant cavity LEDs (RCLEDs) or micro cavity LEDs (MCLEDs) could be created as well.

[0094] The foregoing description of one or more embodiments of the invention has been presented for the purposes of illustration and description. It is not intended to be exhaustive or to limit the invention to the precise form disclosed. Many modifications and variations are possible in light of the above teaching. It is intended that the scope of the invention be limited not by this detailed description, but rather by the claims appended hereto.

1. A gallium nitride (GaN) based light emitting diode (LED), wherein light is extracted through a nitrogen face (N-face) of the LED and a surface of the N-face is roughened.

2. The GaN LED of claim 1, wherein the surface of the N-face is roughened into one or more cones.

3. The GaN LED of claim 1, wherein the roughened surface reduces light reflections occurring repeatedly inside the LED, and thus extracts more light out of the LED.

4. The GaN LED of claim 1, wherein the surface of the N-face is roughened by an anisotropic etching.

5. The GaN LED of claim 4, wherein the anisotropic etching is a dry etching.

6. The GaN LED of claim 4, wherein the anisotropic etching is a photo-enhanced chemical (PEC) etching.

7. The GaN LED of claim 1, wherein the N-face is an n-type layer of the GaN LED.

8. The GaN LED of claim 1, wherein the N-face is prepared by a laser lift off (LLO) technique.

9. The GaN LED of claim 1, wherein the LED is grown on a c-plane GaN wafer and a gallium face (Ga-face) is a p-type layer.

10. The GaN LED of claim 1, wherein the LED is comprised of an n-type electrode, n-type layer, active region, p-type layer and p-type electrode.

11. The GaN LED of claim 10, wherein the n-type layer, active region and p-type layer are each comprised of a (B, Al, Ga, In) N alloy.

12. The GaN LED of claim 10, wherein the p-type electrode has a property of high reflection to decrease light absorption and to increase light reflection toward the surface of the n-type layer.

13. The GaN LED of claim 10, wherein the LED includes a current-blocking layer aligned under the n-type electrode to keep the current from concentrating below the n-type electrode, so that absorption of light emission under the n-type electrode can be avoided and extraction efficiency can be increased.

14. The GaN LED of claim 10, wherein the LED includes a current-confining frame made of an insulator to restrain leakage current through the sidewalls of the LED without significantly decreasing an emitting area.

15. The GaN LED of claim 2, wherein the roughened surface is comprised of a plurality of hexagonal shaped cones that have an angle equal to or smaller than:

$$2 \sin^{-1}(n_{\text{air}}/n_s) \approx 47.2^\circ$$

for GaN, where n_{air} is a refractive index of air and n_s is a refractive index of GaN.

16. The GaN LED of claim 2, wherein the roughened surface is comprised of a plurality of hexagonal shaped cones that have an angle equal to or smaller than:

$$2 \sin^{-1}(n_{\text{enc}}/n_s)$$

for epoxy, where n_{enc} is a refractive index of epoxy and n_s is a refractive index of GaN.

17. A method of creating a gallium nitride (GaN) based light emitting diode (LED), wherein light is extracted through a nitrogen face (N-face) of the LED, comprising:

roughening a surface of the N-face into one or more cones.

18. A light emitting diode (LED) comprised of an n-type electrode, n-type layer, active region, p-type layer and p-type electrode, wherein a surface of the n-type layer is roughened by an anisotropic etching into one or more cones and light is extracted through the roughened surface of the n-type layer.

* * * * *