



(19) **United States**

(12) **Patent Application Publication**

Sato et al.

(10) **Pub. No.: US 2007/0139333 A1**

(43) **Pub. Date: Jun. 21, 2007**

(54) **OPTICAL ELEMENT**

Publication Classification

(76) Inventors: **Susumu Sato**, Akita-shi (JP); **Mao Ye**, Akita-shi (JP)

(51) **Int. Cl.**
G09G 3/36 (2006.01)

(52) **U.S. Cl.** **345/90**

Correspondence Address:

OBLON, SPIVAK, MCCLELLAND, MAIER & NEUSTADT, P.C.
1940 DUKE STREET
ALEXANDRIA, VA 22314 (US)

(57) **ABSTRACT**

The focal distance can be greatly changed by performing an electrical control in an optical element. The optical element comprises a first substrate having a first electrode, a second substrate, a second electrode arranged outside the second substrate, and a liquid crystal layer provided between the first substrate and the second substrate and constituted by liquid crystal molecules oriented. A first voltage is applied between the first electrode and the second electrode, thereby controlling the orientation of the liquid crystal molecules, whereby the optical element operates. A third electrode is provided on an insulating layer and outside the second electrode. A second voltage independent of the first voltage is applied to the third electrode, thereby changing the optical properties.

(21) Appl. No.: **11/678,794**

(22) Filed: **Feb. 26, 2007**

Related U.S. Application Data

(63) Continuation of application No. PCT/JP05/15464, filed on Aug. 25, 2005.

(30) **Foreign Application Priority Data**

Aug. 26, 2004 (JP) 2004-246860
Feb. 28, 2005 (JP) 2005-052626

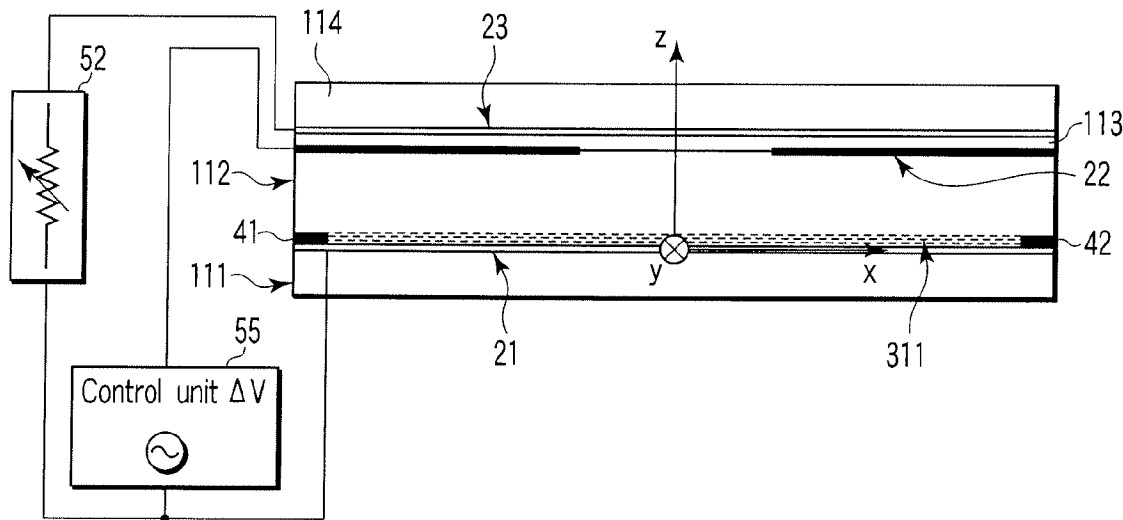

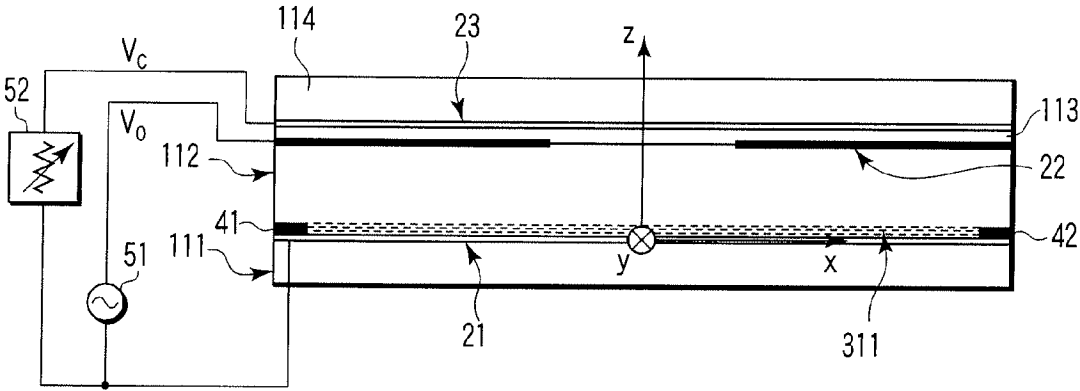

FIG. 1A

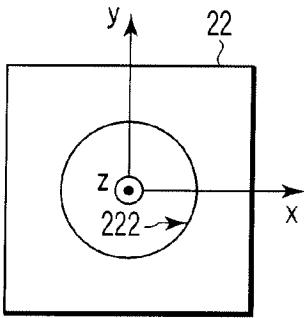

FIG. 1B

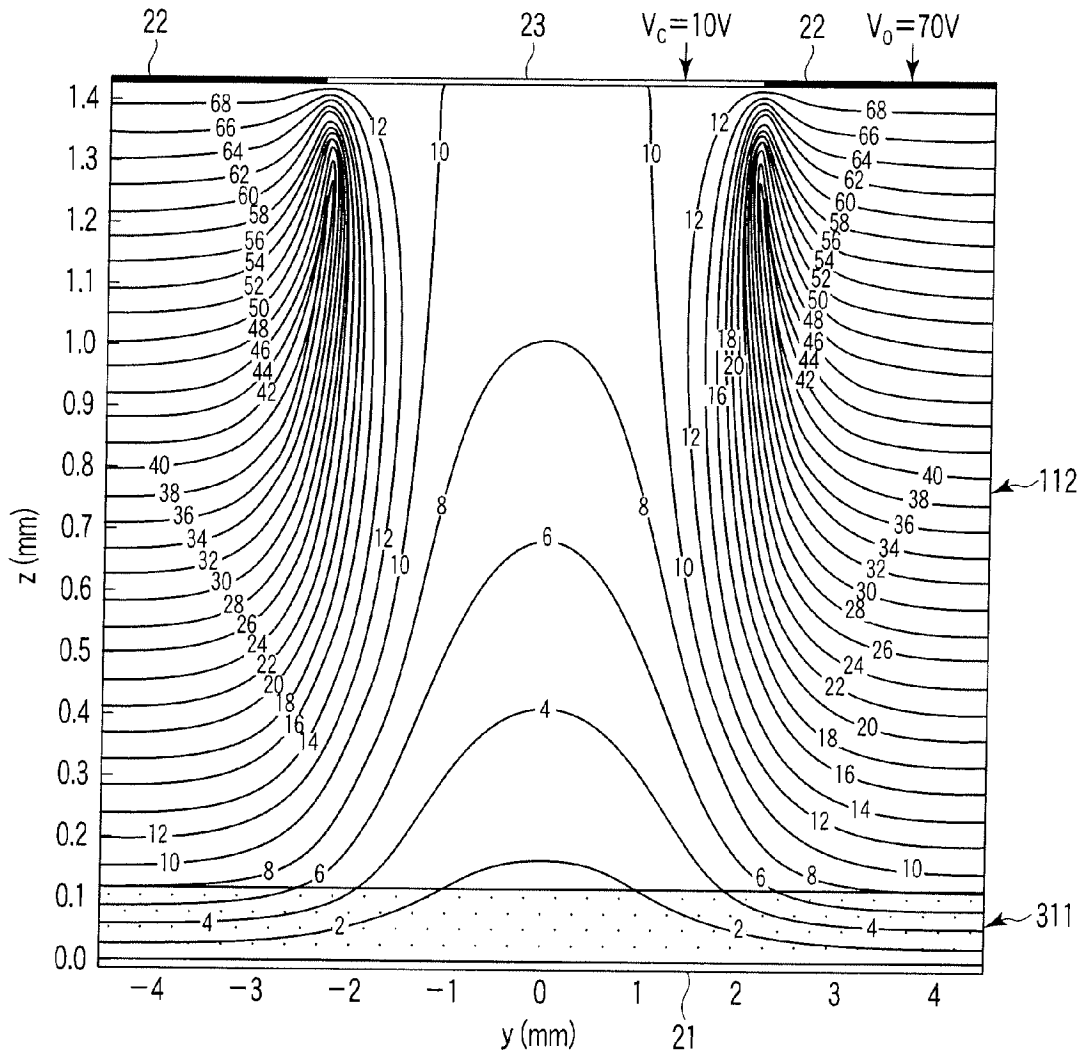

FIG. 2

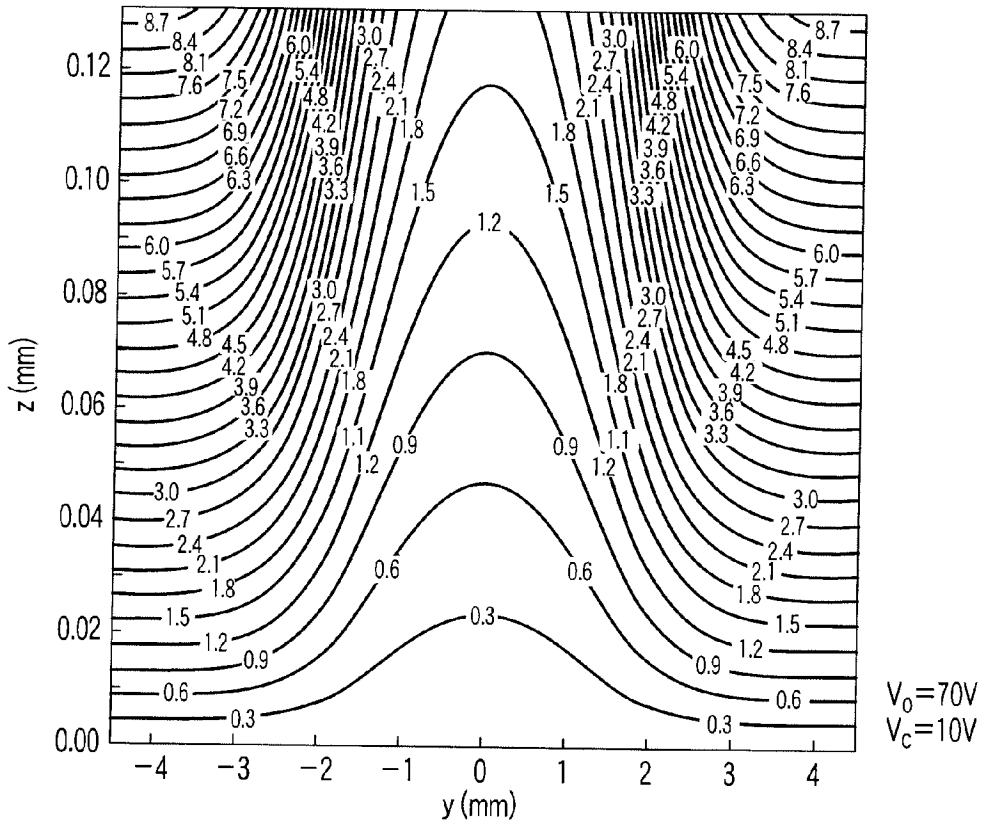

FIG. 3A

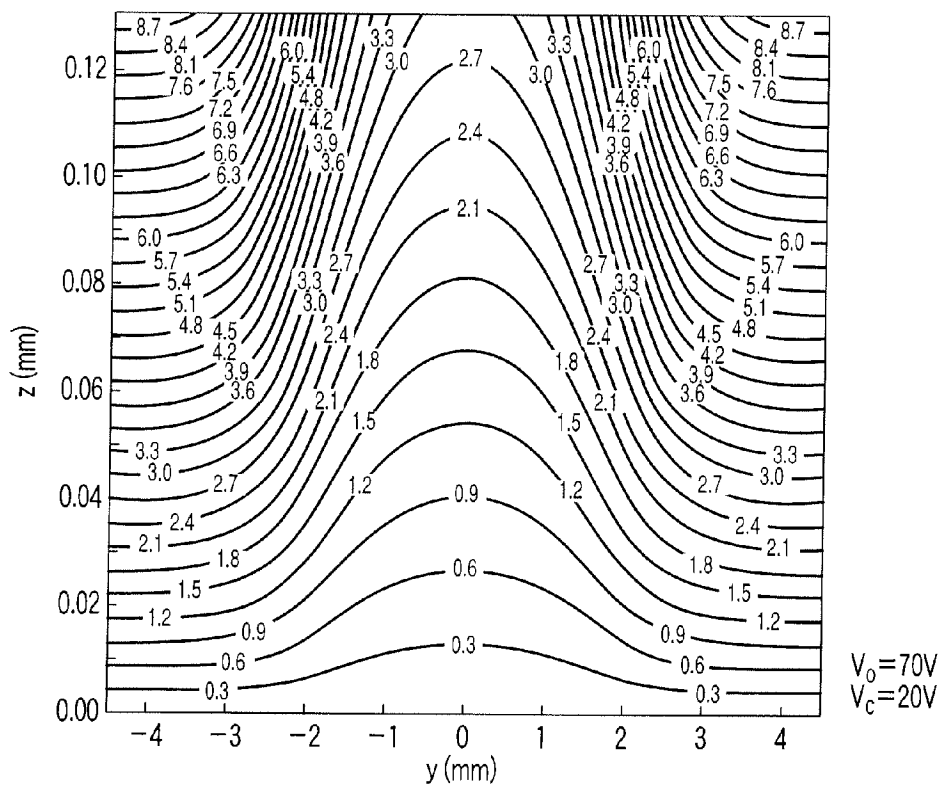

FIG. 3B

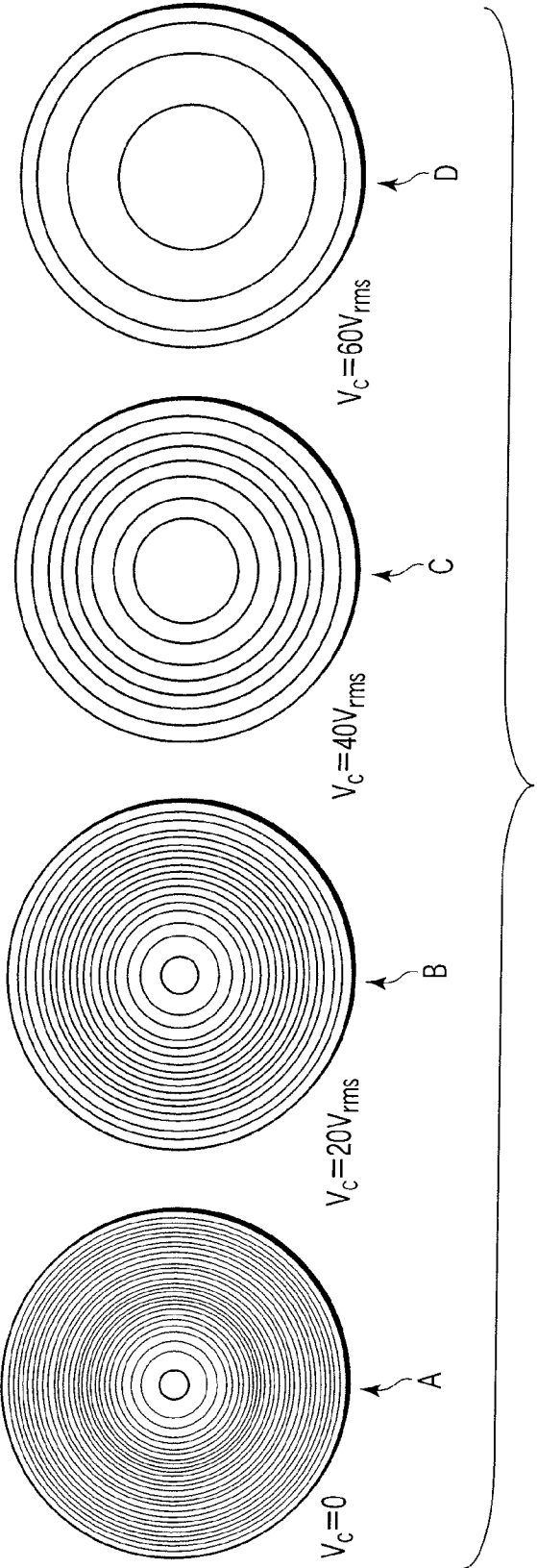

FIG. 4

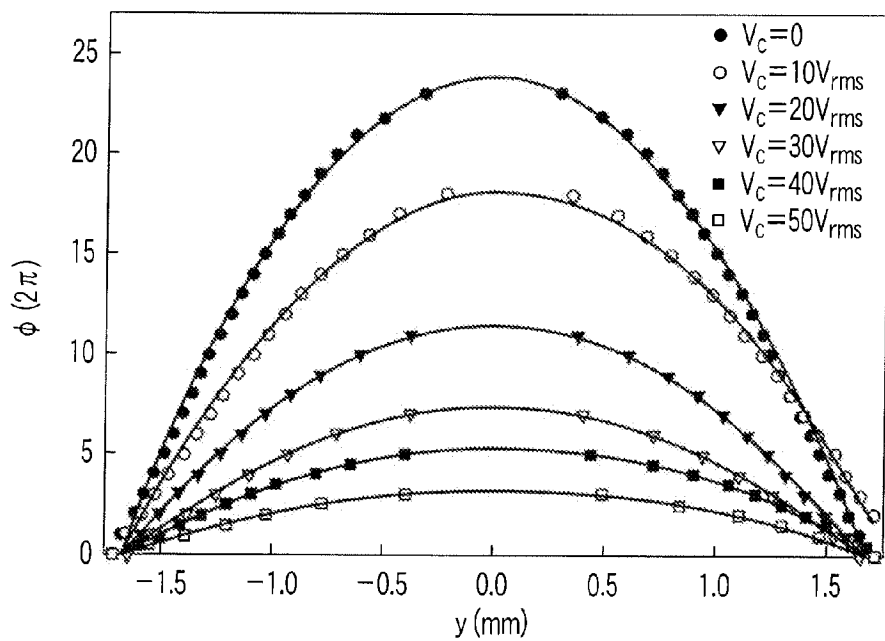

FIG. 5

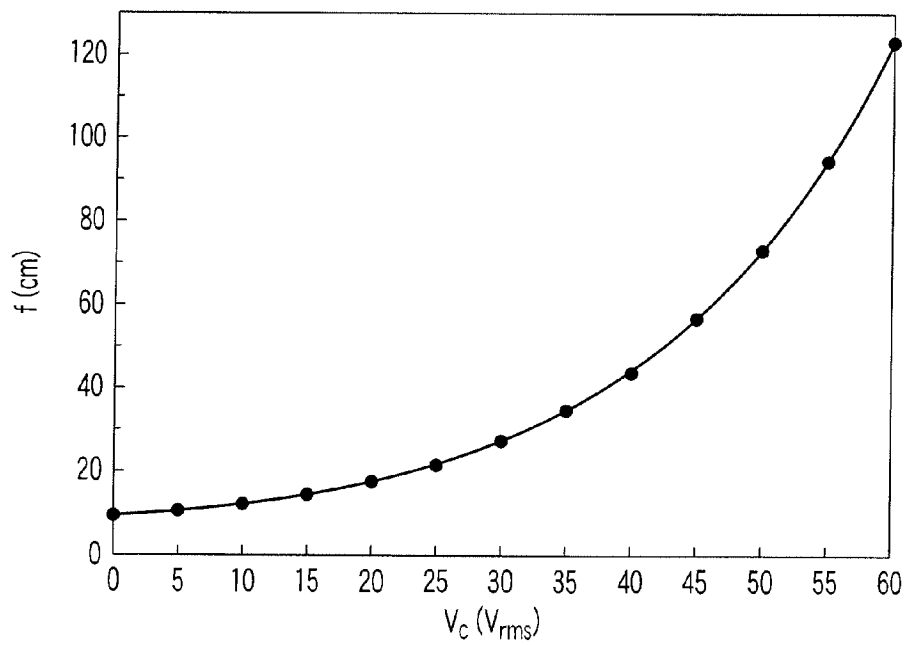

FIG. 6

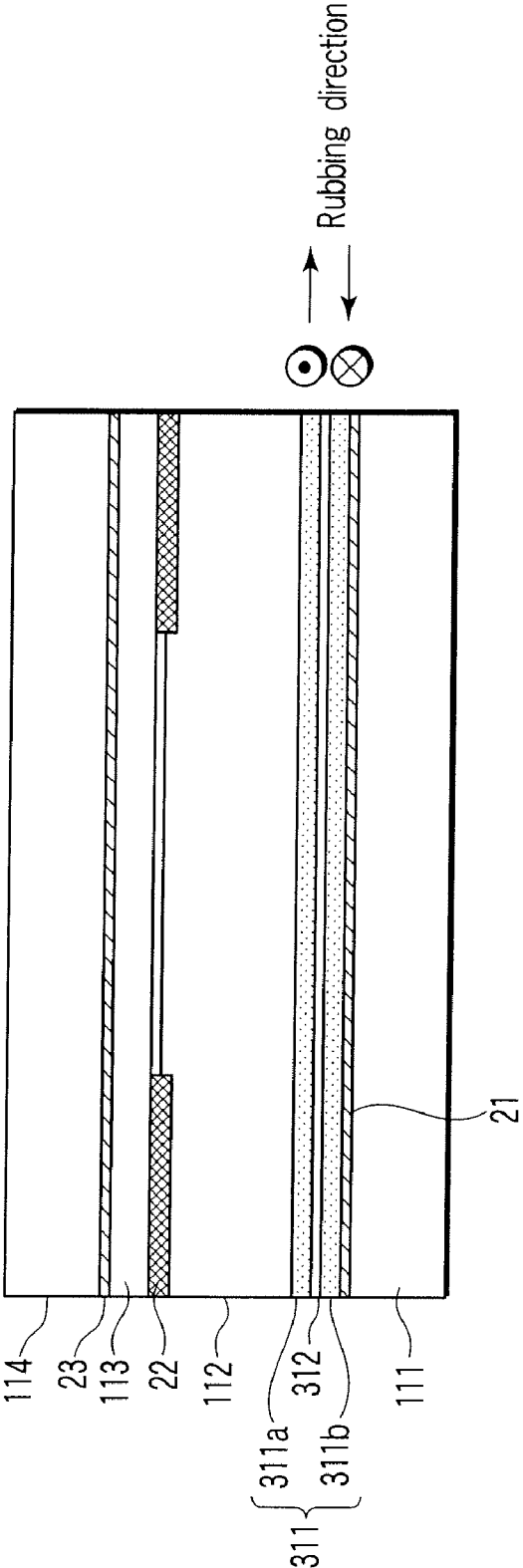

FIG. 7

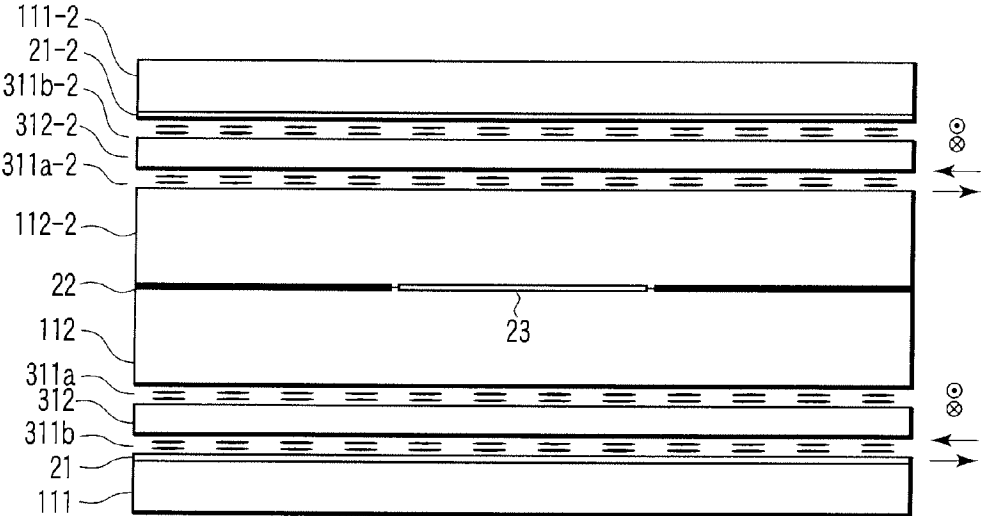

FIG. 8A

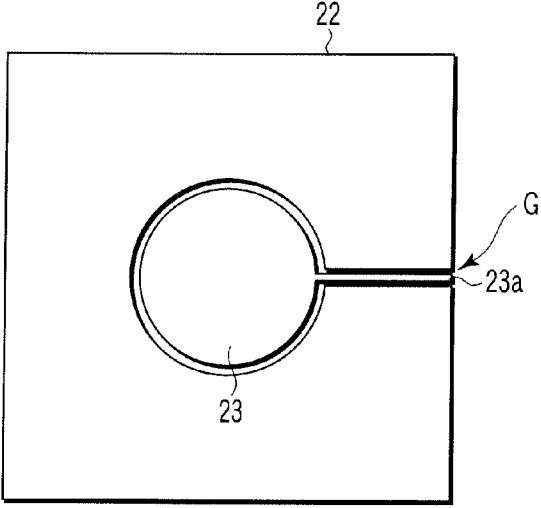

FIG. 8B

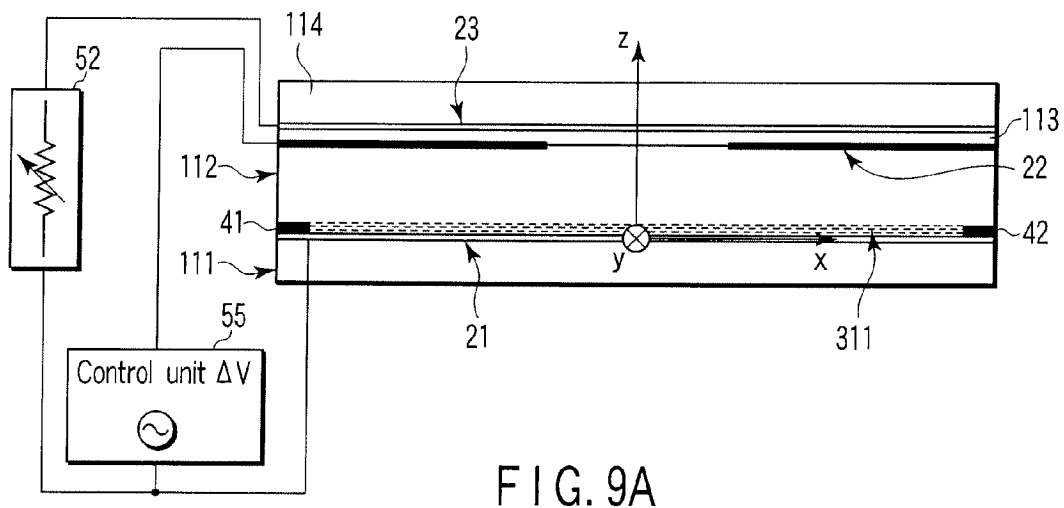

FIG. 9A

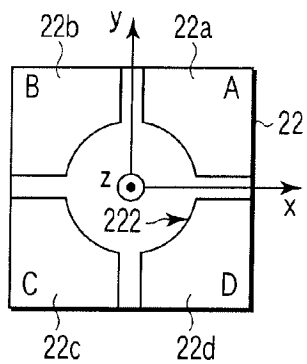

FIG. 9B

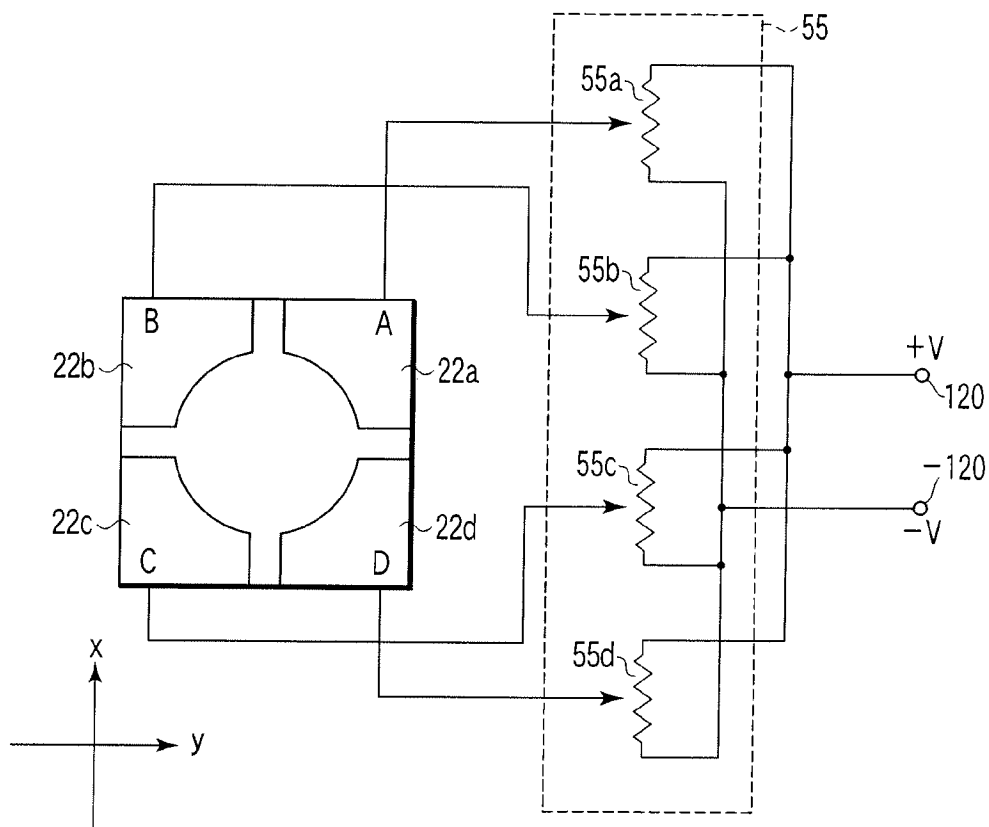

FIG. 10A

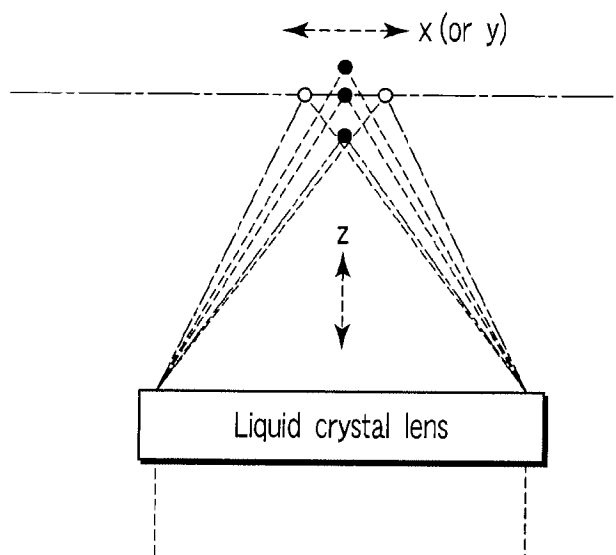

FIG. 10B

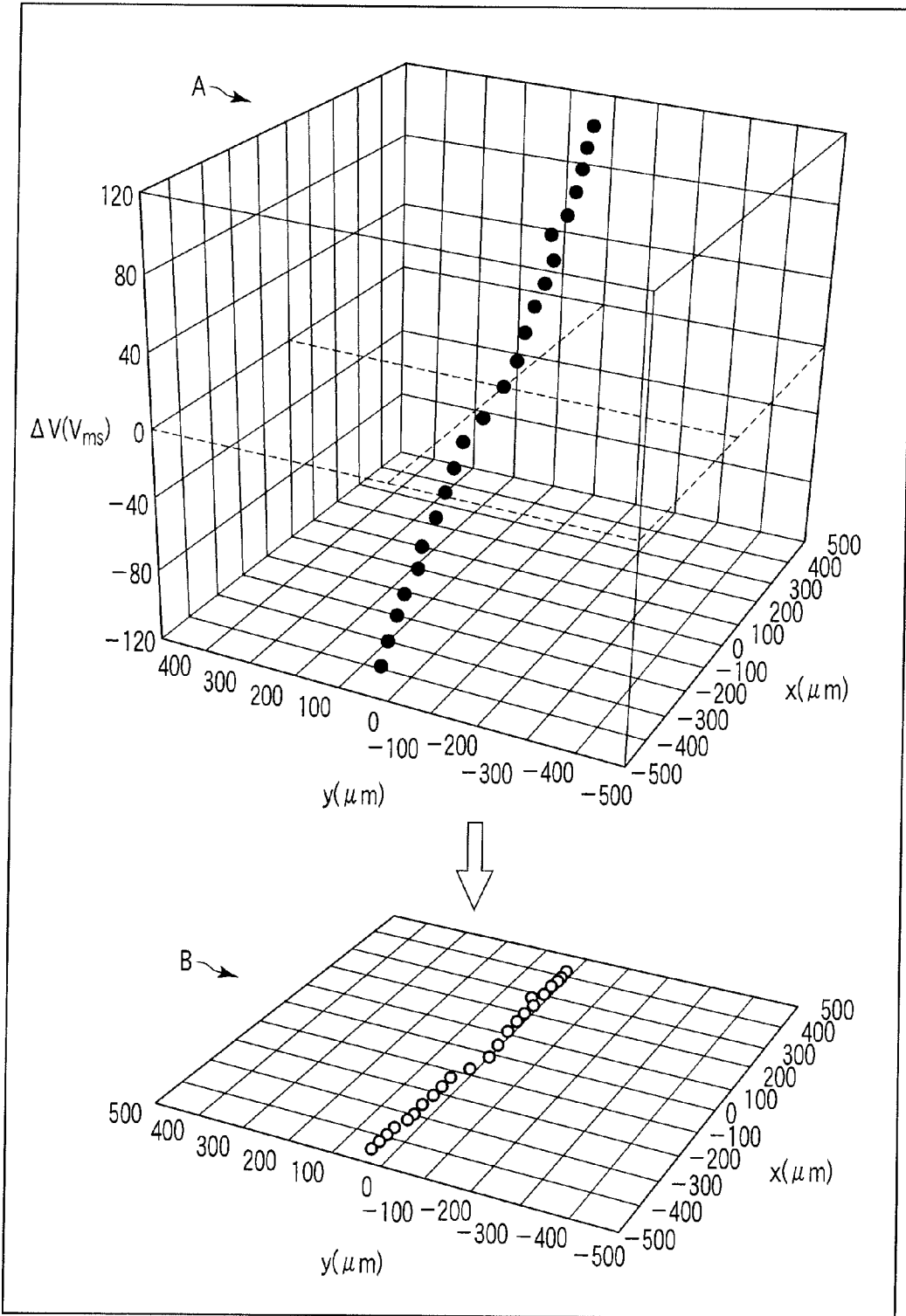

FIG. 11

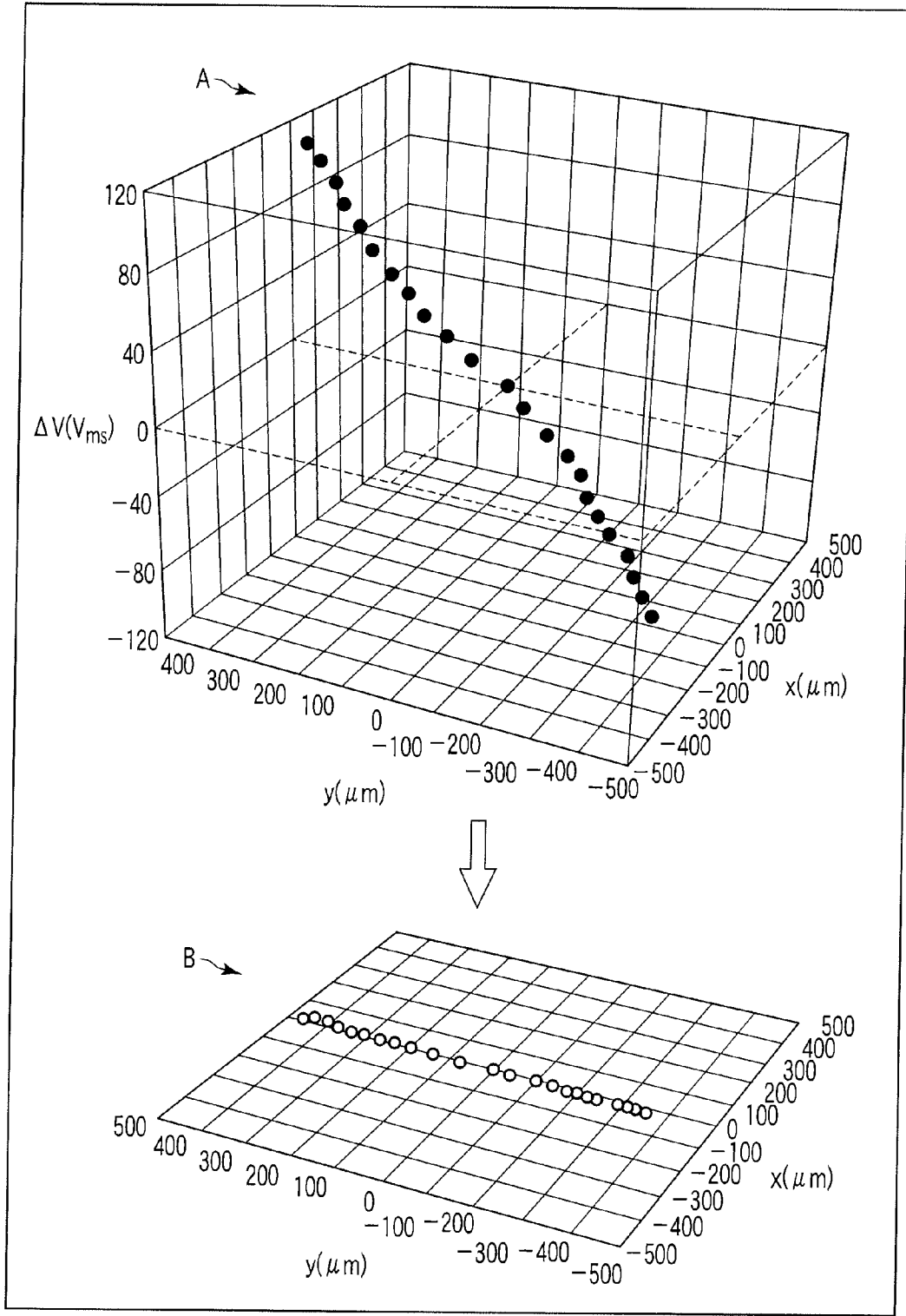

FIG. 12

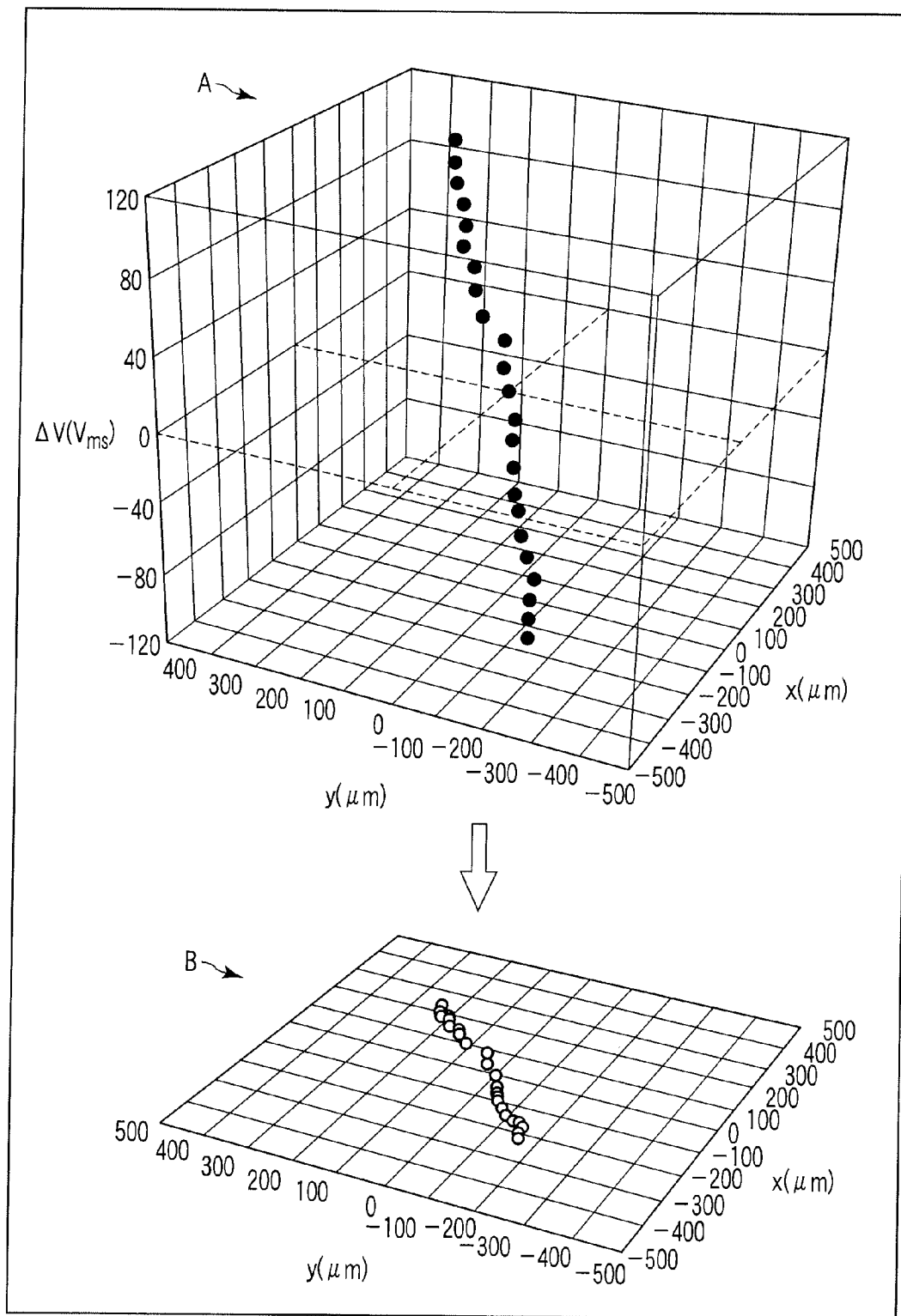

FIG. 13

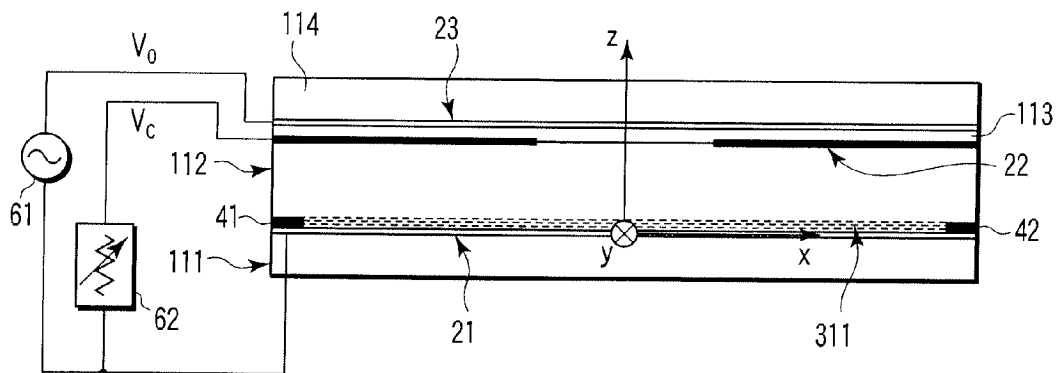

FIG. 14A

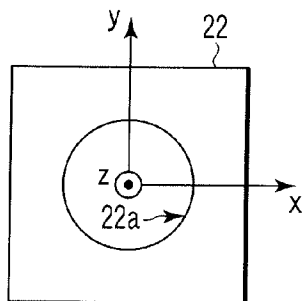

FIG. 14B

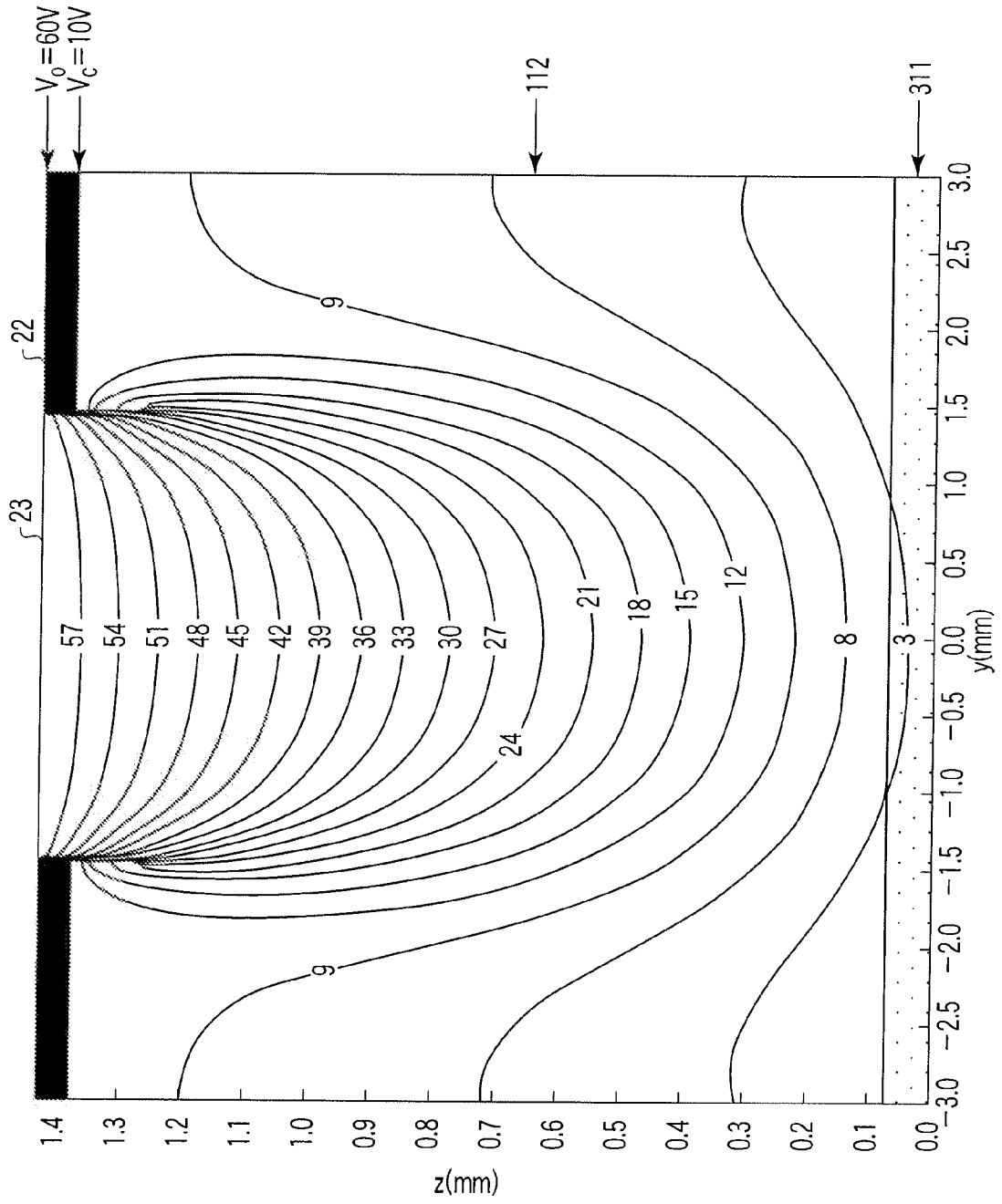

FIG. 15

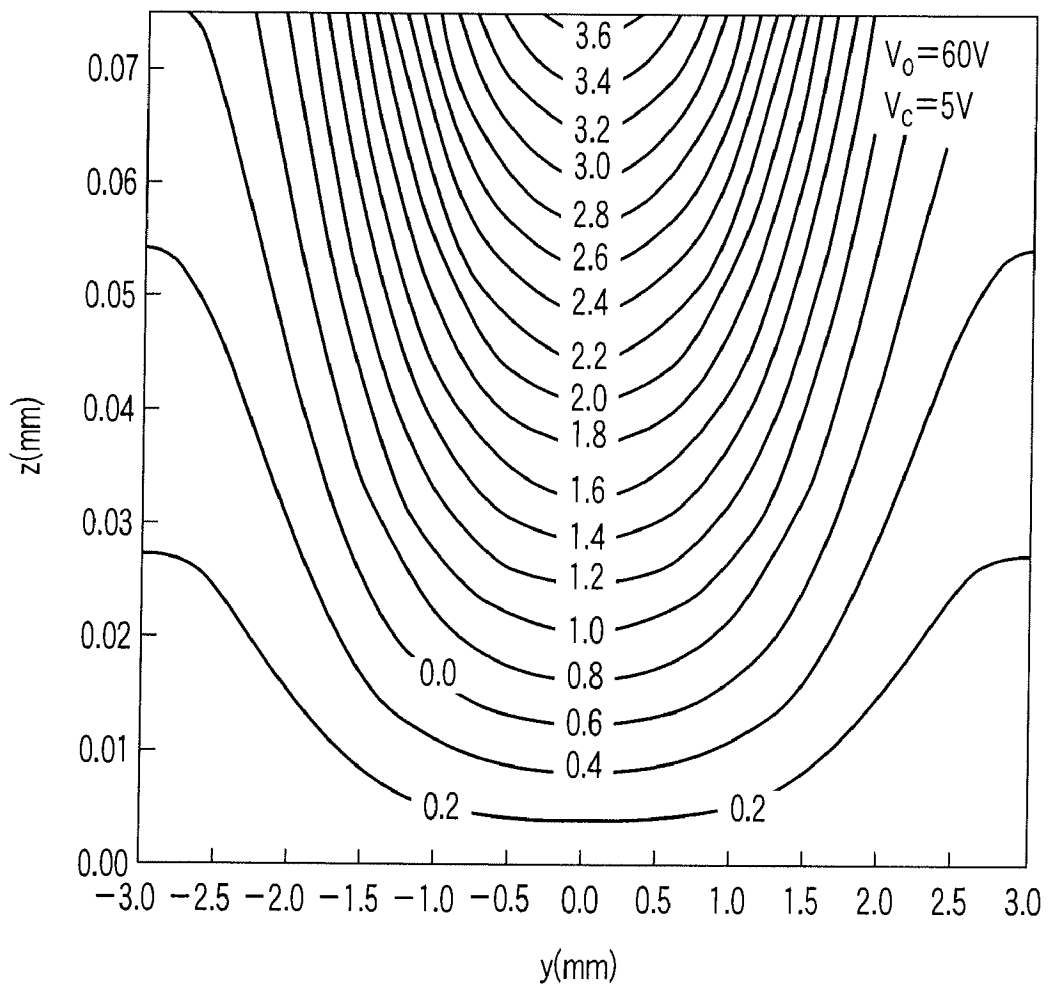

FIG. 16A

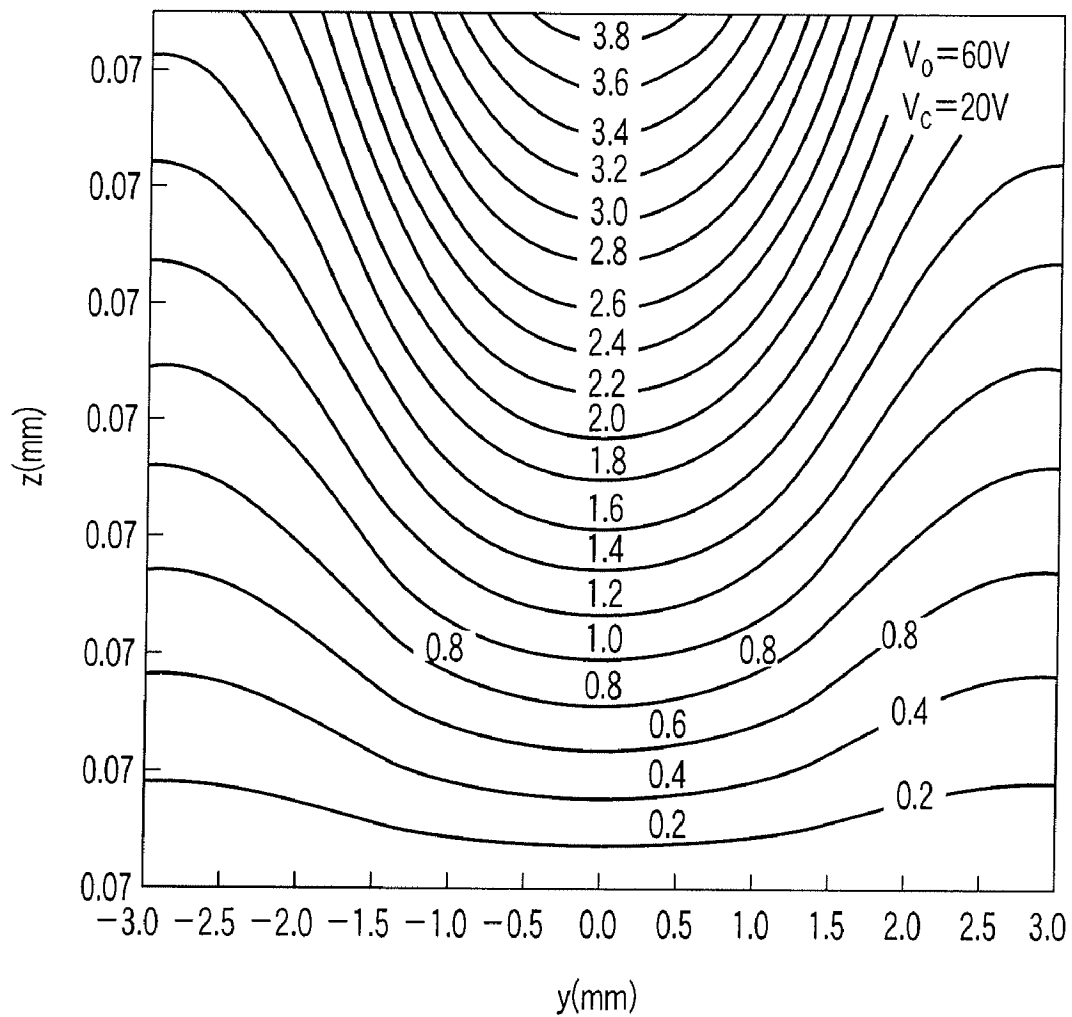

FIG. 16B

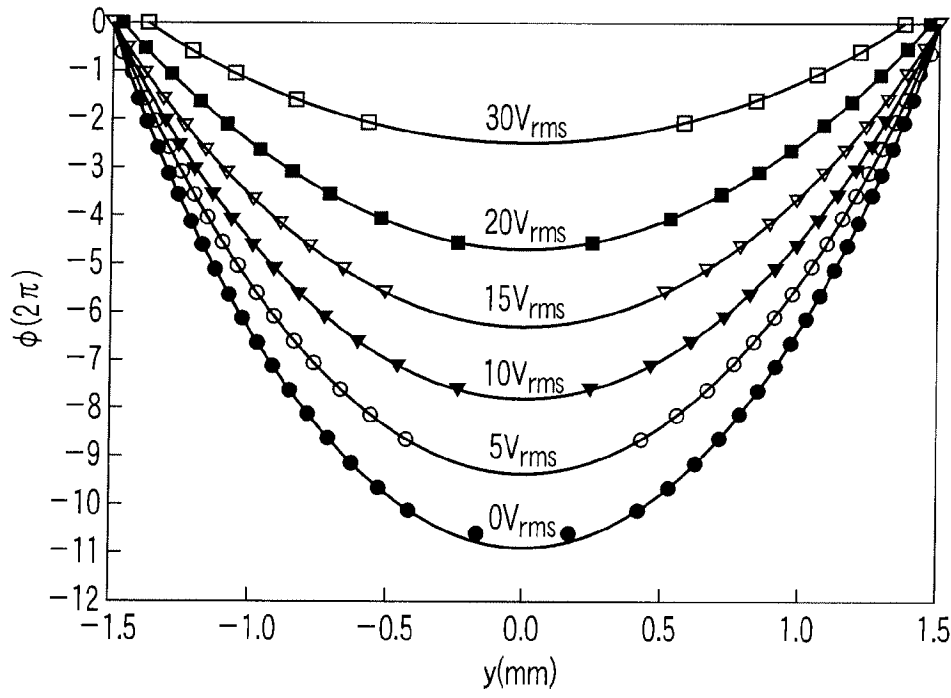

FIG. 17

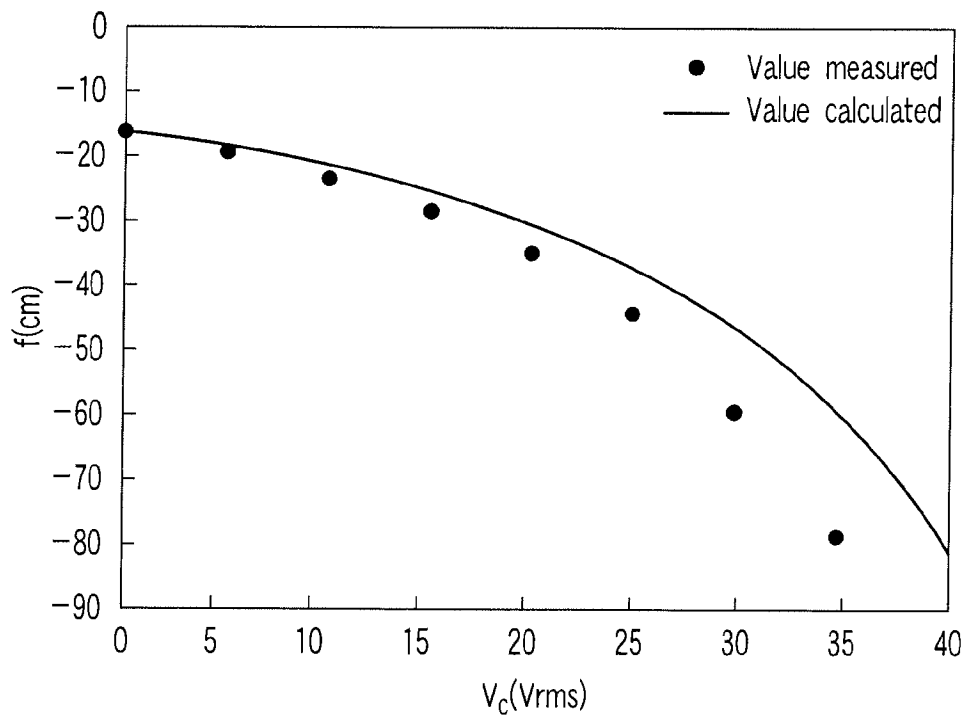

FIG. 18

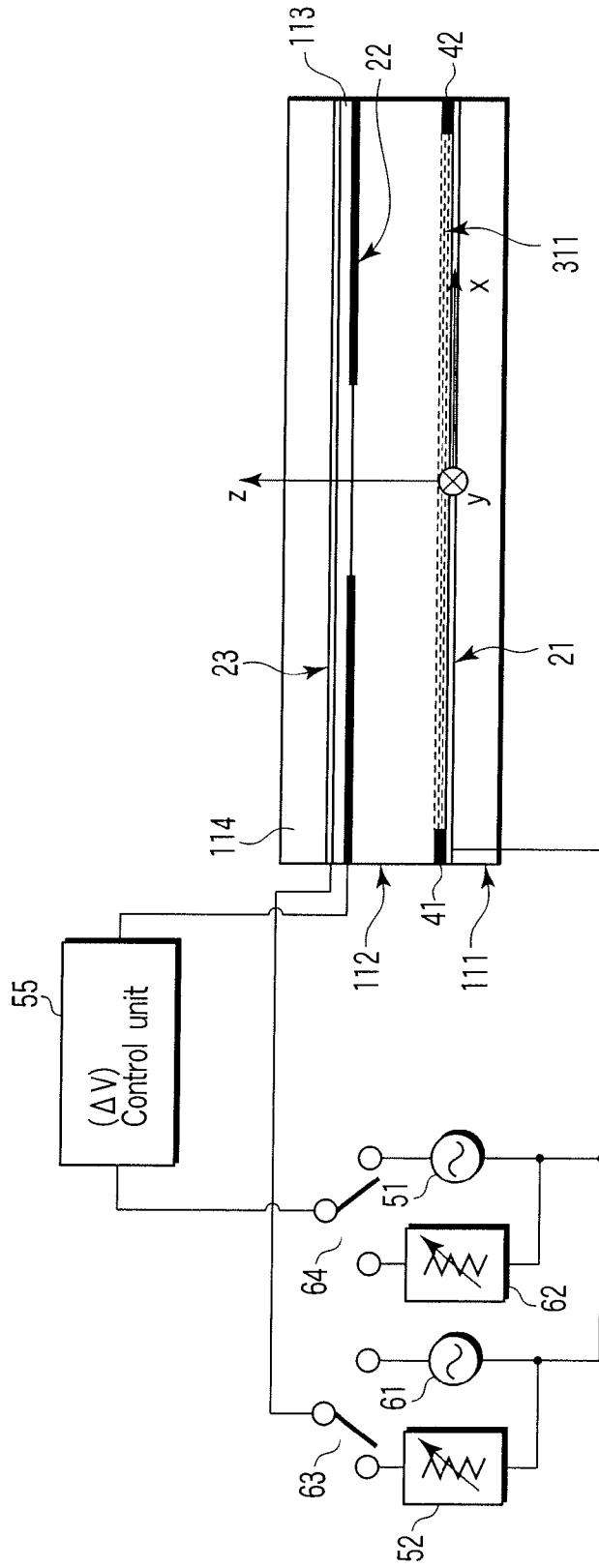

FIG. 19

OPTICAL ELEMENT**CROSS REFERENCE TO RELATED APPLICATIONS**

[0001] This is a Continuation Application of PCT Application No. PCT/JP2005/015464, filed Aug. 25, 2005, which was published under PCT Article 21 (2) in Japanese.

[0002] This application is based upon and claims the benefit of priority from prior Japanese Patent Applications No. 2004-246860, filed Aug. 26, 2004; and No. 2005-052626, filed Feb. 28, 2005, the entire contents of both of which are incorporated herein by reference.

BACKGROUND OF THE INVENTION**[0003] 1. Field of the Invention**

[0004] The present invention relates to an optical element in which two different voltages are applied between an electrode provided on a substrate constituting a liquid crystal cell and an electrode provided outside the substrate to control the orientation of liquid crystal molecules and in which specific optical properties can be easily adjusted.

[0005] 2. Description of the Related Art Liquid crystal has fluidity as liquid and exhibits anisotropy in electro-optical properties. The orientation of liquid crystal molecules can be controlled in various ways. The properties of the liquid crystal have been utilized, developing thin and light weight, flat-type display devices have been remarkably developed in recent years. The orientation of the liquid crystal molecules can be easily controlled if two glass plates constituting a liquid crystal element and having a transparent conductive film are surface-treated and if a voltage is externally applied. The refractive index of any liquid crystal element of this type can be continuously varied from the value it exhibits to extraordinary light to the value it exhibits to ordinary light. This is an excellent property not present in other optical materials.

[0006] Focus-variable lenses have been proposed, each of which has the effective refractive index varied (see Patent Document 1 and Non-Patent Documents 1 and 2). Glass substrates having transparent electrodes are bent by utilizing the electro-optical effect of nematic liquid crystal. The liquid crystal layer is thereby shaped like a lens, unlike in the element structure incorporated in the ordinary liquid crystal display. A voltage is applied across the electrodes, controlling the orientation of the liquid crystal molecules. The effective refractive index of the lens is thereby varied.

[0007] A method is available in which a spatial distribution of refractive index is imparted to an optical medium, thereby attaining a lens effect. Such optical media, known as SELFOC (GRIN) lenses, are commercially available. In a nematic liquid crystal cell, the liquid crystal molecules are oriented in the direction of an electric field. Methods of providing liquid crystal lenses that exhibit a spatial distribution of refractive indices have been reported (see Patent Document 2, Patent Document 3, and Non-Patent Documents 3 and 4). In these methods, an electrode having a circular pattern is used, generating an axially symmetrical non-uniform electric field, and obtaining such a liquid crystal lens by utilizing the effect of the liquid-crystal molecular orientation.

[0008] As Patent Document 4 discloses, a mesh-like macromolecule network in the liquid crystal in order to improve the properties of the liquid crystal. It is comparatively easy to modify such a lens using liquid crystal into a microlens array that comprises a number of tiny, so-called microlenses arranged two-dimensionally, thus forming a flat plate.

[0009] It has been proposed that, in a liquid crystal microlens, a pair of electrodes should be provided outside the electrode of a circular pattern to improve the lens properties (see Non-Patent Document 5). Further, a method has been proposed, in which an insulating layer is inserted between a liquid crystal layer and an electrode having a circular pattern, and the requirement that the ratio of the diameter of the circular pattern to the thickness of the liquid crystal layer should be 2:1 to about 3:1 to impart optimal properties to a microlens is mitigated (see Non-Patent Documents 6 and 7).

[0010] On the other hand, an optical apparatus has been proposed, which uses a liquid crystal element instead of a lens mirror (see Patent Document 5). In this apparatus, an imaging device detects an optical image obtained by an optical system having a focusing unit with an aberration-correcting mechanism, and the aberration is determined from a signal generated by the imaging device. A signal for correcting the aberration is generated, thereby correcting the aberration occurring in the optical system due to a sway of the atmosphere, in order to provide an optical image that is not distorted. Further, an electric-field controlled, anamorphic liquid crystal lens having an elliptical distribution of refractive index has been proposed as a lens that utilizes a liquid-crystal optical element (see Non-Patent Document 8).

[0011] Unlike the ordinary optical element, which is a passive element, these optical elements using liquid crystal can provide lenses that can adjust properties, such as focal distance, and the aberration of an optical system.

[0012] Polymerization-curable liquid crystal can be used as liquid crystal material. In this case, the liquid crystal is polymerized and is thereby cured, providing a polymer lens, after the focal distance is adjusted (see Patent Document 6).

[0013] Pat. Doc. 1: Jpn. Pat. Appln. KOKAI Publication No. 54-151854

[0014] Pat. Doc. 2: Jpn. Pat. Appln. KOKAI Publication No. 11-109303

[0015] Pat. Doc. 3: Jpn. Pat. Appln. KOKAI Publication No. 11-109304

[0016] Pat. Doc. 4: Jpn. Pat. Appln. KOKAI Publication No. 10-239676

[0017] Pat. Doc. 5: Jpn. Pat. Appln. KOKAI Publication No. 03-265819

[0018] Pat. Doc. 6: Jpn. Pat. Appln. KOKAI Publication No. 09-005695

[0019] Non-Pat. Doc. 1: S. Sato, "Liquid-crystal lens-cell with variable focal length", Japanese Journal of Applied Physics, 1979, Vol. 18, pp. 1679-1683

[0020] Non-Pat. Doc. 2: S. Sato, "Liquid crystals and application thereof", Sangyo Tosho Co., Ltd., Oct. 14, 1984, pp. 204-206

[0021] Non-Pat. Doc. 3: T. Nose and S. Sato, "A liquid-crystal micro lens obtained with a non uniform electric field", Liquid Crystals, 1989, pp. 1425-1433

[0022] Non-Pat. Doc. 4: S. Sato, "The world of liquid crystal", Sangyo Tosho Co., Ltd., Apr. 15, 1994, pp. 186-189

[0023] Non-Pat. Doc. 5: M. Honma, T. Nose and S. Sato, "Enhancement of numerical aperture of liquid crystal micro-lenses using a stacked electrode structure", Japanese Journal of Applied Physics, August 2000, Vol. 39, No. 8, pp. 4799-4802

[0024] Non-Pat. Doc. 6: M. Ye and S. Sato, "Optical properties of liquid crystal lens of any size", Preliminary reports, 49th meeting of the Applied Physics Society, March 2002, 28p-X-10, p. 1277

[0025] Non-Pat. Doc. 7: M. Ye and S. Sato, "Optical properties of liquid crystal lens of any size", Japanese Journal of Applied Physics, May 2002, Vol. 41, No. 5, pp. L571-L573

[0026] Non-Pat. Doc. 8: Y. Yokoyama, M. Ye and S. Sato, "Electrically controllable liquid crystal anamorphic lens", 2004 preliminary reports, meeting of the Society of Liquid Crystal, Japan, Sep. 26, 2004

BRIEF SUMMARY OF THE INVENTION

[0027] The liquid crystal lens having a lens-shaped liquid crystal layer, the liquid crystal microlens utilizing the spatial refractive-index distribution of liquid crystal molecules, achieved by an axially symmetrical non-uniform electric field and generated by a circular-pattern electrode, a method in which a pair of electrodes are provided outside a circular-pattern electrode, as proposed in Non-Patent Document 5, and a structure in which an insulating layer is provided between a liquid crystal layer and a circular-pattern electrode, as proposed in Non-Patent Documents 6 and 7, all described above, can attain good optical properties. They have a problem, however. They can hardly acquire good properties over a wide range of the voltage applied.

[0028] Accordingly, an object of one embodiment of this invention is to provide an optical element that has good optical properties, which can be changed easily and greatly while being maintained.

[0029] An object of another embodiment of this invention is to provide an optical element in which the focus can be moved in a three-dimensional fashion.

[0030] An object of still another embodiment of this invention is to provide such optical properties as can be controlled for either convex lenses or concave lenses.

[0031] To solve the above-mentioned problem, an optical element according to this invention comprises basically a first substrate having a first electrode, a second substrate, a second electrode arranged outside the second substrate and having a hole, and a liquid crystal layer provided between the first substrate and the second substrate and constituted by liquid crystal molecules oriented in one direction. A first voltage is applied between the first electrode and the second electrode, controlling the orientation of the liquid crystal molecules, whereby the optical element operates. In the optical element, a third electrode is arranged outside the second electrode and provided on an insulating layer, and a second voltage, which is independent of the first voltage, is applied to the third electrode, thereby controlling the optical properties.

[0032] Owing to the means described above, the focal position can be greatly varied by electrical control, without mechanically moving the lens back and forth as in the conventional optical element.

BRIEF DESCRIPTION OF THE SEVERAL VIEWS OF THE DRAWING

[0033] FIG. 1A is a sectional view showing the configuration of an embodiment of an optical element according to the present invention;

[0034] FIG. 1B is a plan view showing the configuration of the embodiment of the optical element according to this invention;

[0035] FIG. 2 is a diagram showing a potential distribution in the element, and thus explaining the function of the optical element according to this invention;

[0036] FIG. 3A is a diagram showing a first example in which the potential distribution changes in the optical element according to this invention, and thus explaining the function of the optical element;

[0037] FIG. 3B is a diagram showing a second example in which the potential distribution changes in the optical element according to this invention, and thus explaining the function of the optical element;

[0038] FIG. 4 is a diagram showing how a light wave passing through the optical element according to this invention changes in optical phase, as viewed in the optical axis of the optical element;

[0039] FIG. 5 is a diagram showing how a light wave passing through the optical element according to this invention changes in optical phase, and thus explaining the function of the optical element;

[0040] FIG. 6 is a diagram showing how the focal distance changes with the control voltage, and thus explaining the function of the optical element according to this invention;

[0041] FIG. 7 is a sectional view showing the configuration of another embodiment of the optical element according to the present invention;

[0042] FIG. 8A is a sectional view showing the configuration of a further embodiment of the optical element according to the present invention;

[0043] FIG. 8B is a plan view showing the configuration of the further embodiment of the optical element according to this invention;

[0044] FIG. 9A is a sectional view showing the configuration of another embodiment of the optical element according to the present invention;

[0045] FIG. 9B is a plan view showing the configuration of the other embodiment of the optical element according to this invention;

[0046] FIG. 10A is a diagram explaining the specific configuration of the control unit shown in FIG. 9;

[0047] FIG. 10B is a diagram explaining how the focus of the liquid crystal lens is moved in the control unit shown in FIG. 9;

[0048] FIG. 11 is a diagram showing the potential applied to the split electrode shown in FIG. 10 and the x-direction movement of the focus, both actually measured;

[0049] FIG. 12 is a diagram showing the potential applied to the split electrode shown in FIG. 10 and the y-direction moment of the focus, both actually measured;

[0050] FIG. 13 is a diagram showing the potential applied to the split electrode shown in FIG. 10 and the movement of the focus in a direction at an angle to the x-direction and the y-direction, both the potential and the movement having been actually measured;

[0051] FIG. 14A is a sectional view showing the configuration of a further embodiment of the optical element according to the present invention;

[0052] FIG. 14B is a plan view showing the configuration of the further embodiment of the optical element according to this invention;

[0053] FIG. 15 is a diagram showing a potential distribution in the optical element of FIGS. 14A and 14B, and thus explaining the function of this optical element;

[0054] FIG. 16A is a diagram showing a first example in which the potential distribution changes in the optical element of FIGS. 14A and 14B, and thus explaining the function of this optical element according;

[0055] FIG. 16B is a diagram showing a second example in which the potential distribution changes in the optical element of FIGS. 14A and 14B, and thus explaining the function of this optical element;

[0056] FIG. 17 is a diagram showing how a light wave passing through the optical element of FIG. 14 changes in optical phase, and thus explaining the function of this optical element;

[0057] FIG. 18 is a diagram showing how the focal distance changes with the control voltage, and thus explaining the function of the optical element shown in FIG. 14; and

[0058] FIG. 19 is a diagram showing the configuration of another embodiment of the optical element according to the present invention.

DETAILED DESCRIPTION OF THE INVENTION

[0059] Embodiments of the present invention will be described in detail, with reference to the accompanying drawings. FIGS. 1A and 1B, number 111 designates a first substrate (transparent glass plate). A first electrode 21 (made of ITO) is formed on the inner surface of the first substrate 111. On the side of the first electrode 21, a second substrate 112 (transparent glass plate) is arranged, facing the first electrode 21 and extending parallel thereto. Outside the second substrate 112, a second electrode 22 (made of Al) is formed. As shown in FIG. 1B, the second electrode 22 has a circular hole 222 (having a diameter of, for example, 4.5 mm).

[0060] A liquid crystal layer 311 (having a thickness of, for example, 130 μm) is formed between the first electrode 21, which is formed on the first substrate 111, and the second substrate 112. Reference numbers 41 and 42 denote spacers that define the liquid crystal layer 311.

[0061] Further, an insulating layer 113 (e.g., glass layer as thin as, for example, 70 μm) is provided on the upper surface of the second electrode 22, and a third electrode 23 (made of ITO) is formed on the insulating layer 113. A protective layer 114 (made of glass) is arranged on the upper surface of the third electrode 23. Those surfaces of the first and second substrates, which contact the liquid crystal layer, are coated with polyimide and have been rubbed in the x-axis direction.

[0062] To make the optical element function as a liquid crystal lens, a first voltage V_0 is applied between the first electrode 21 and the second electrode 22. To apply the first voltage V_0 , a second voltage V_c is initially set to 0 V and the first voltage V_0 is set to an appropriate value. The voltage V_0 is applied from a voltage-applying unit 51. The voltage is set to such a value as will impart optimum optical properties (hereinafter referred to as first-stage optical properties) to the lens. Next, a second voltage V_c , which is independent of the first voltage V_0 , is applied between the first electrode 21 and the third electrode 23. The second voltage V_c is output from a voltage-applying unit 52. If the second voltage V_c is varied, the optical properties (hereinafter referred to as second-stage optical properties) of the lens can be controlled. Note that V_0 and V_c are identical in frequency and phase.

[0063] In the present invention, the second-stage optical properties are changed from the values at which the focal distance is very short to the values at which the focal distance is infinitely long or almost infinitely long. The focal distance can vary over a broad range. Hence, the present invention is practically valuable and can be applied to various uses.

[0064] FIG. 2 shows a potential distribution in the space between the first and second electrodes, which is observed when $V_0=70$ V (fixed value for optimal properties) is applied between the first electrode 21 and the second electrode 22 and the second voltage (control voltage) $V_c=10$ V is applied to the third electrode 23. In FIG. 2, z is the optical-axis direction, and y is the direction intersecting at right angles with the optical axis. Note that z , y and x are identical to z , y and x shown in FIG. 1. If the equipotential lines define a steep gradient, the lens will have a short focal distance. If they define a gentle gradient, the lens will have a long focal distance.

[0065] FIG. 3A and FIG. 3B show other potential distributions, i.e., two potential distributions that may be observed in the liquid crystal layer. FIG. 3A shows a potential distribution that is observed when $V_0=70$ V (a fixed value for optimum properties) is applied between the first electrode 21 and the second electrode 22 and the second voltage (control voltage) $V_c=10$ V is applied between the first electrode 21 and the third electrode 23. FIG. 3B shows a potential distribution that is observed when the control voltage is varied and the second voltage (control voltage) $V_c=20$ V is applied. This change in the potential distribution corresponds to the inclination angle of the liquid crystal molecules and to the refractive angle of light. The focal distance is longer in the state of FIG. 3B than in the state of FIG. 3A.

[0066] In FIG. 4, A, B, C and D show how the phase of a light wave is distributed as viewed in the optical axis of the optical element according to this invention. More precisely, A, B, C and D show how the phase distribution of the light

wave changes as the control voltage V_c applied to the third electrode **23** is varied to 0 V, 20 V, 40 V and 60 V, while applying the fixed voltage $V_0=70$ V to the first electrode **21** and second electrode **22**. As seen from A to D in FIG. 4, the higher the control voltage V_c , the longer the spaces between the interference fringes. The longer the spaces between the interference fringes, the less prominent the refraction of the light will be and, hence, the longer the focal distance will be.

[0067] FIG. 5 shows how a light wave passing through a liquid crystal lens comes to have an optical phase delay ϕ . Basically, the light has square-distribution characteristic. Therefore, its phase delay gradually decreases outwards from the y axis. As the control voltage (second voltage) is increased, the phase difference between the center of the lens and the periphery thereof decreases. Thus, the focal distance is longer when $V_c=50$ V than when $V_c=10$ V.

[0068] FIG. 6 represents the relation between the change in the focal distance of the optical element according to this invention and the control voltage V_c mentioned above. The focal distance varies as the control voltage V_c is changed. The present invention is not limited to the embodiment described above.

[0069] FIG. 7 shows the configuration of another embodiment of the present invention. The components identical to those shown in FIG. 1 are denoted by the same reference numbers. This embodiment differs from the first embodiment in the structure of the liquid crystal layer **311**. In the present embodiment, the liquid crystal layer **311** is composed of a first liquid crystal layer **311a**, a second liquid crystal layer **311b**, and an insulating layer **312** (made of transparent glass). The first and second liquid crystal layers **311a** and **311b** are spaced apart, with the insulating layer **312** interposed between them.

[0070] Thus configured, the liquid crystal layer **311** can respond at an extremely high speed. The response speed of any liquid crystal layer is inversely proportional to the square of the layer thickness. Hence, the layer **311** can respond to a control signal four times faster than the element of FIG. 1, because it comprises two liquid crystal layers, i.e., the first layer **311a** and the second layer **311b**.

[0071] Having a two-layer structure, the liquid crystal layer **311** can achieve the following advantage. If the liquid crystal layers **311a** and **311b** have been rubbed in the same direction, the liquid crystal molecules are oriented in the same direction in both layers **311a** and **311b**. As a result, the lens can acquire a magnifying power twice as large as that of a single-layer lens. In other words, it can attain the same effect as two lenses combined together and can, therefore, a short focal distance.

[0072] Further, the lens can function as a liquid crystal element without a polarizing plate if the liquid crystal layers **311a** and **311b** have been rubbed in two directions intersecting at right angles, respectively.

[0073] FIG. 8A and FIG. 8B show still another embodiment of the present invention. This optical element is composed of two elements that are identical to the element shown in FIG. 7. It is a two-unit structure having an upper unit and a lower unit that are symmetrical to each other. The components (first element unit) identical to those shown in FIG. 7 are designated by the same reference numerals. The first and second element units share the second and third

electrodes **22** and **23**. The second element unit is laid on the first element unit. The second element unit has substrates **111-2** and **112-2**, an electrode **21-2**, a first liquid crystal layer **311a-1**, a second liquid crystal layer **311b-2**, an insulating layer **312-2**, a common second electrode **22**, and a common third electrode **23**. In this embodiment, a gap G is provided between the second electrode **22** and the third electrode **23**, because these electrodes **22** and **23** lie in the same plane. The second electrode **22** has a slit **23a** that extends from its hole to one of its sides. A lead line **23a** is led from the third electrode **23**, through the slit **23a**. A control voltage V_c is applied through the lead line **23a**.

[0074] The upper liquid crystal layer and the lower liquid crystal layer, which are symmetrical to each other, may be composed of two or more layers each. If this is the case, the lens power and the response speed will be further improved.

[0075] In the present invention, the liquid crystal layers may be made of material of two-frequency driven type, which that functions as N-type when driven by a high-frequency signal (tens of kilohertz) and as P-type when driven by a low-frequency signal (about 100 Hz). If the liquid crystal layers are made of such material, the response speed of the orienting operation of liquid crystal molecules can be raised.

[0076] FIG. 9A and FIG. 9B show another embodiment of the present invention. In the embodiment shown in FIGS. 1A and 1B, a fixed voltage is applied to the second electrode **22**. In this embodiment, the second electrode **22** is divided into two or more segments, for example four electrode segments **22a** to **22d** as shown in FIG. 9B. The voltages applied to these electrodes can be minutely changed by a control unit **55**. In any other respect, this embodiment is identical to the embodiment of FIGS. 1A and 1B.

[0077] FIG. 10A shows the configuration of the control unit **55**. FIG. 10B explains how the focus moves when the control unit **55** controls the position of the focus.

[0078] The voltage applied to the electrode segment **22a** comes from the sliding tap of a variable resistor **55a**. Its value is ranges from voltage $+V$ and voltage $-V$. Similarly, the voltage applied to the electrode **22b** comes from the sliding tap of a variable resistor **55b** and ranges voltage $+V$ and voltage $-V$; the voltage applied to the electrode **22c** comes from the sliding tap of a variable resistor **55c** and ranges voltage $+V$ and voltage $-V$; and the voltage applied to the electrode **22d** comes from the sliding tap of a variable resistor **55d** and ranges voltage $+V$ and voltage $-V$.

[0079] As the voltages applied to the electrode segments **22a** to **22d** are minutely changed, the focus can be moved in the x-axis direction or the y-axis direction, or in both directions. In addition, the focus can be moved in the z-axis direction. Thus, the focal position can be controlled in a three-dimensional fashion.

[0080] In FIG. 11, A and B show how the focal position is controlled in the x-axis direction while being held in the focal plane, by adjusting the voltage V_c . More precisely, A in FIG. 11 shows how the focus moves in a space as the voltage applied to the second electrode **22** is changed. B in FIG. 12 shows the position the focus takes in the focal plane.

[0081] In FIG. 12, A and B show how the focal position is controlled in the y-axis direction. More precisely, A in FIG.

12 shows how the focus moves in a space as the voltage applied to the second electrode **22** is changed. **B** in FIG. **12** shows the distance the focus moves.

[**0082**] In FIG. **13**, **A** and **B** show how the focal position is controlled in the x-axis direction and the y-axis direction. Namely, **A** in FIG. **13** shows the voltage applied to the second electrode **22**, and **B** in FIG. **13** shows the distance the focus moves.

[**0083**] This invention is not limited to the embodiments described above. In these embodiments, the liquid crystal lens functions as a convex lens. Nonetheless, the liquid crystal lens can be easily made to work as a concave lens, too, according to the present invention.

[**0084**] FIGS. **14A** and **14B** shows an embodiment in which the liquid crystal lens functions as a concave lens. In this case, a voltage-applying unit **61** applies a constant AC voltage V_0 between the first electrode **21** and the third electrode **23**, and a voltage-applying unit **62** applies the voltage V_c between the first electrode **21** and the second electrode **22**. The voltage V_c can be varied. In any other respect, this embodiment is identical to the embodiment shown in FIGS. **1A** and **1B**.

[**0085**] FIG. **15** depicts a potential distribution observed when the voltage $V_0=60$ V (i.e., fixed value for attaining optical properties) is applied between the first electrode **21** and the third electrode **23** and the second voltage (control voltage) $V_c=10$ V is applied between the first electrode **21** and the second electrode **22**. In FIG. **15**, z is the direction in which the optical axis extends, and y is a direction intersecting at right angles with the optical axis. Note, z , y and x are identical to their equivalents shown in FIGS. **1A** and **1B**. The potential distribution is inverse to the distribution shown in FIG. **2**. This means that the liquid crystal lens works as a concave lens.

[**0086**] FIG. **16A** and FIG. **16B** show different potential distributions. FIG. **16A** shows a potential distribution observed when $V_0=60$ V (i.e., fixed value for attaining optical properties) is applied between the first electrode **21** and the third electrode **23** and the second voltage (control voltage) $V_c=5$ V is applied between the second electrode **22**. FIG. **16B** shows a potential distribution observed when the second voltage (control voltage) V_c is changed to 20V and applied. The change in this potential difference corresponds to the inclination angle of the liquid crystal molecules and also to the refractive angle of light. The potential distributions shown in FIGS. **16A** and **16B** are inverse to those shown in FIGS. **3A** and **3B**. This means that the liquid crystal lens works as a concave lens.

[**0087**] FIG. **17** shows how light has an optical phase delay ϕ as it passes through the liquid crystal lens. Basically, the phase delay of a light wave has square-distribution characteristic. Therefore, its phase delay gradually decreases outwards from the y axis. As the control voltage (second voltage) is changed, the phase difference between the center of the lens and the periphery thereof is controlled. That is, the concave-lens property can be varied.

[**0088**] FIG. **18** is a diagram showing how the focal distance changes with the control voltage V_c described above. When the control voltage V_c is varied, the focal distance is changed.

[**0089**] The present invention is not limited to the embodiments described above, in which the liquid crystal lens is either a convex lens or a concave lens. In the present invention, a convex lens and a concave lens may be used in combination.

[**0090**] FIG. **19** shows a multi-function lens that is a combination of the embodiment of FIGS. **1A** and **1B** (i.e., an embodiment that functions as a convex lens) and the embodiment of FIGS. **9A** and **9B** (i.e., an embodiment in which the focal position can be controlled in a three-dimensional fashion) and the embodiment of FIGS. **14A** and **14B** (i.e., an embodiment that functions as a concave lens). The function of this lens can be switched the switch **64** and **65**, between the convex-lens function and the concave-lens function. While the lens is functioning as a convex lens, the voltages applied to the segments of the second electrode are minutely adjusted independently of one another, thereby to the focus in a three-dimensional fashion. While the lens is functioning as a concave lens, too, the voltages applied to the segments of the second electrode may be controlled independently of one another.

[**0091**] The present invention is not limited to the embodiments described above. The components of any embodiment can be modified in various manners in reducing the invention to practice, without departing from the spirit or scope of the invention. Further, the components of any embodiment described above may be combined, if necessary, in various ways to make different inventions. For example, some of the component of any embodiment may not be used. Moreover, the components of the different embodiments may be combined in any desired fashion. The shape of the third electrode may be defined by a sine-wave function, the superimposed function of a sine-wave function, or an any power function. In the embodiments described above has one liquid crystal lens. Nonetheless, a plurality of liquid crystal lenses may be arranged, forming a linear array or a two-dimensional array.

[**0092**] Optical elements according to the present invention can be used in various ways. They may be used as magnifying lenses or in the visual-sense unit for use in robots.

What is claimed is:

1. An optical element which comprises a first substrate having a first electrode, a second substrate, a second electrode arranged outside the second substrate and having a hole, and a liquid crystal layer provided between the first substrate and the second substrate and constituted by liquid crystal molecules oriented, and in which a first voltage is applied between the first electrode and the second electrode to control an orientation of the liquid crystal molecules,

wherein a third electrode is arranged on an insulating layer and outside the second electrode and configured to receive a second voltage that is independent of the first voltage; and the first voltage has a fixed value that imparts optimal first-stage optical properties to the optical element, and the second voltage is changed to vary second-stage optical properties of the optical element.

2. An optical element which comprises a first substrate having a first electrode, a second substrate, a second electrode arranged outside the second substrate and having a hole, and a liquid crystal layer provided between the first substrate and the second substrate and constituted by liquid crystal molecules oriented, and in which a first voltage

is applied between the first electrode and the second electrode to control an orientation of the liquid crystal molecules,

wherein a third electrode is arranged on an insulating layer and outside the second electrode and configured to receive a second voltage that is independent of the first voltage; and the second voltage has a fixed value that imparts optimal first-stage optical properties to the optical element, and the first voltage is changed to vary second-stage optical properties of the optical element.

3. The optical element according to claim 1 or 2, wherein the second electrode having a hole is divided into a plurality of electrode segments around an optical axis, and control voltages independent of one another are applied to the electrode segments, respectively.

4. The optical element according to claim 1 or 2, wherein the third electrode has a shape defined by a sine-wave function, the superimposed function of a sine-wave function, or any power function.

5. The optical element according to claim 1 or 2, wherein one insulating layer divides the liquid crystal layer into a first liquid crystal layer and a second liquid crystal layer, or a plurality of insulating layers divide the liquid crystal layer into a plurality of liquid crystal layers.

6. The optical element according to claim 1 or 2, wherein one or more insulating layers divide the liquid layer into liquid crystal layers arranged such that the liquid crystal molecules are oriented parallel to, or at right angles to, one another.

7. The optical element according to claim 1 or 2, wherein the liquid crystal layer is made of two-frequency driven type that functions as N-type when driven by a high-frequency signal and as P-type when driven by a low-frequency signal.

8. An optical element comprising:

- a first substrate having a first electrode on an inner surface;
- a second substrate facing the inner surface of the first substrate;
- a second electrode provided outside the first substrate and having a hole;
- a first liquid crystal layer provided between the first substrate and the second substrate and constituted by liquid crystal molecules;
- a third electrode arranged and connected by insulating parts to the second electrode;
- a third substrate arranged symmetrical to the second substrate, with respect to the third electrode;
- a fourth substrate having a second liquid crystal layer and a third liquid crystal layer which are arranged symmetrical to the first liquid crystal layer and the first substrate, respectively, with respect to the second and third electrode and the third substrate; and

means for applying a first voltage between the first and second electrodes and between the second and fourth

electrodes, and for applying to the third electrode a second voltage independent of the first voltage.

9. The optical element according to claim 8, wherein an insulating layer divides the first liquid crystal layer into a third liquid crystal layer and a fourth liquid crystal layer, and an insulating layer divides the second liquid crystal layer into a third liquid crystal layer and a fourth liquid crystal layer.

10. The optical element according to claim 8, wherein the third electrode is arranged, spaced apart from the hole of the second electrode.

11. An optical element which comprises a first substrate having a first electrode, a second substrate, a second electrode arranged outside the second substrate and having a hole, and a liquid crystal layer provided between the first substrate and the second substrate and constituted by of liquid crystal molecules oriented, and in which a first voltage is applied between the first electrode and the second electrode to control an orientation of the liquid crystal molecules,

wherein a third electrode is arranged on an insulating layer and outside the second electrode and configured to receive a second voltage that is independent of the first voltage; a circuit is provided which changes the second voltage, while holding the first voltage a fixed value, thereby controlling optical properties to make the optical element function as a convex lens; and a circuit is provided which changes the first voltage, while holding the second voltage to a fixed value, thereby controlling the properties to make the optical element function as a concave lens.

12. An optical element which comprises a first substrate having a first electrode, a second substrate, a second electrode arranged outside the second substrate and having a hole, and a liquid crystal layer provided between the first substrate and the second substrate and constituted by of liquid crystal molecules oriented, and in which a first voltage is applied between the first electrode and the second electrode to control an orientation of the liquid crystal molecules,

wherein a third electrode is arranged on an insulating layer and outside the second electrode and configured to receive a second voltage that is independent of the first voltage; a first circuit is provided which holds the first voltage to a fixed value, thereby optimizing first-stage optical properties based on the first voltage, and changes the second voltage, thereby optimizing second-stage optical properties; a second circuit is provided which holds the second voltage at a fixed value, thereby optimizing third-stage optical properties based on the second voltage, and changes the first voltage, thereby optimizing fourth-stage optical properties; and a switch is provided which performs switching between the first circuit and the second circuit.

* * * * *