



US008741192B2

(12) **United States Patent**  
**Torii et al.**

(10) **Patent No.:** **US 8,741,192 B2**  
(45) **Date of Patent:** **Jun. 3, 2014**

(54) **METHOD AND DEVICE FOR PRODUCING MICRO-DROPLETS**

(75) Inventors: **Toru Torii**, Suginami-ku (JP); **Toshiro Higuchi**, Yokohama (JP); **Takashi Nishisako**, Taitou-ku (JP); **Shingo Okushima**, Setagaya-ku (JP)

(73) Assignee: **Japan Science and Technology Agency**, Kawaguchi-shi (JP)

(\*) Notice: Subject to any disclaimer, the term of this patent is extended or adjusted under 35 U.S.C. 154(b) by 1417 days.

(21) Appl. No.: **10/593,783**

(22) PCT Filed: **Mar. 15, 2005**

(86) PCT No.: **PCT/JP2005/004522**

§ 371 (c)(1),  
(2), (4) Date: **Feb. 2, 2007**

(87) PCT Pub. No.: **WO2005/089921**

PCT Pub. Date: **Sep. 29, 2005**

(65) **Prior Publication Data**

US 2007/0196397 A1 Aug. 23, 2007

(30) **Foreign Application Priority Data**

Mar. 23, 2004 (JP) ..... 2004-083802

(51) **Int. Cl.**

**A61M 31/00** (2006.01)

**A61K 9/00** (2006.01)

**B01L 3/02** (2006.01)

(52) **U.S. Cl.**

USPC ..... **264/4.1**; 422/99; 422/100; 422/101;  
604/500; 424/400; 428/402

(58) **Field of Classification Search**

USPC ..... 516/9; 428/402-402.24; 427/213.36;  
264/4-4.7

See application file for complete search history.

(56) **References Cited**

U.S. PATENT DOCUMENTS

6,149,787 A *	11/2000	Chow et al. ....	204/451
7,268,167 B2 *	9/2007	Higuchi et al. ....	516/9
7,595,195 B2 *	9/2009	Lee et al. ....	436/52
2002/0058332 A1 *	5/2002	Quake et al. ....	435/288.3

FOREIGN PATENT DOCUMENTS

JP	2001 517545	10/2001
JP	2004 122107	4/2004
JP	2004 237177	8/2004
WO	02 068104	9/2002

OTHER PUBLICATIONS

U.S. Appl. No. 12/826,845, filed Jun. 30, 2010, Higuchi, et al.

\* cited by examiner

*Primary Examiner* — James J Seidleck

*Assistant Examiner* — S. Camilla Pourbohloul

(74) *Attorney, Agent, or Firm* — Oblon, Spivak, McClelland, Maier & Neustadt, L.L.P.

(57) **ABSTRACT**

A method and an apparatus for producing various types of microdroplets. The apparatus has a cross intersection portion at which a first continuous phase, a first dispersion phase, and a second dispersion phase intersect with each other. A first liquid feed device controls the first dispersion phase and a second liquid feed device controls the second dispersion phase. A control device is connected to the first liquid feed device and the second liquid feed device. The first liquid feed device and the second liquid feed device are controlled by a signal from the control device so that microdroplets formed of the first dispersion phase and microdroplets formed of the second dispersion phase are sequentially produced.

**3 Claims, 8 Drawing Sheets**

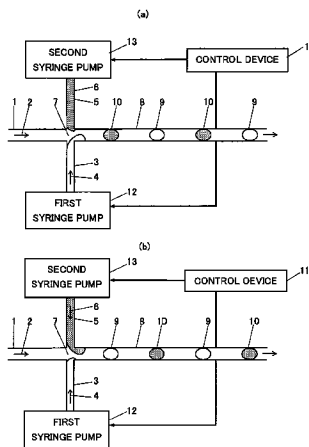
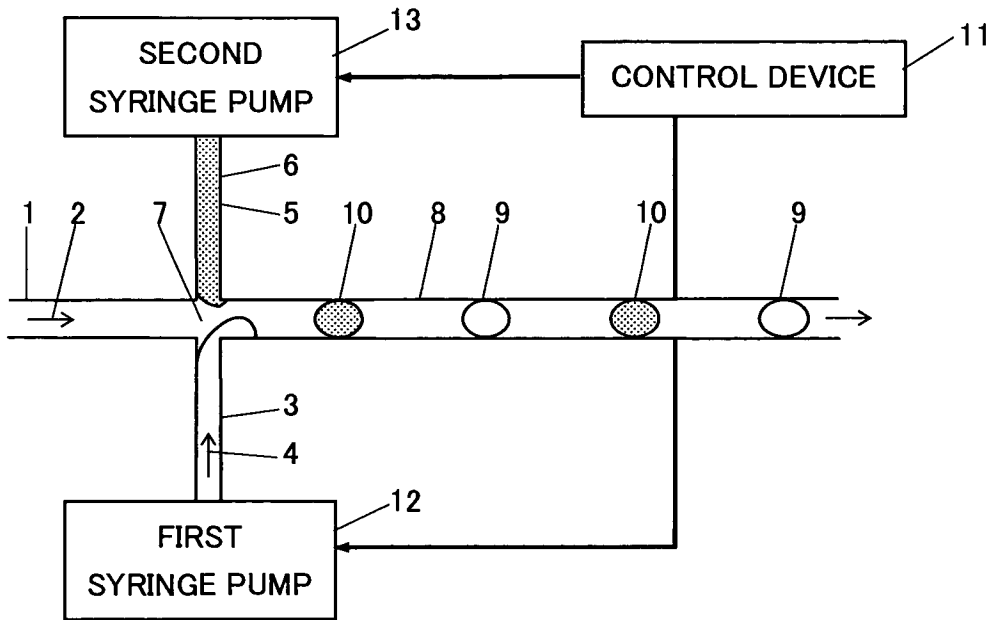

FIG. 1

(a)



(b)

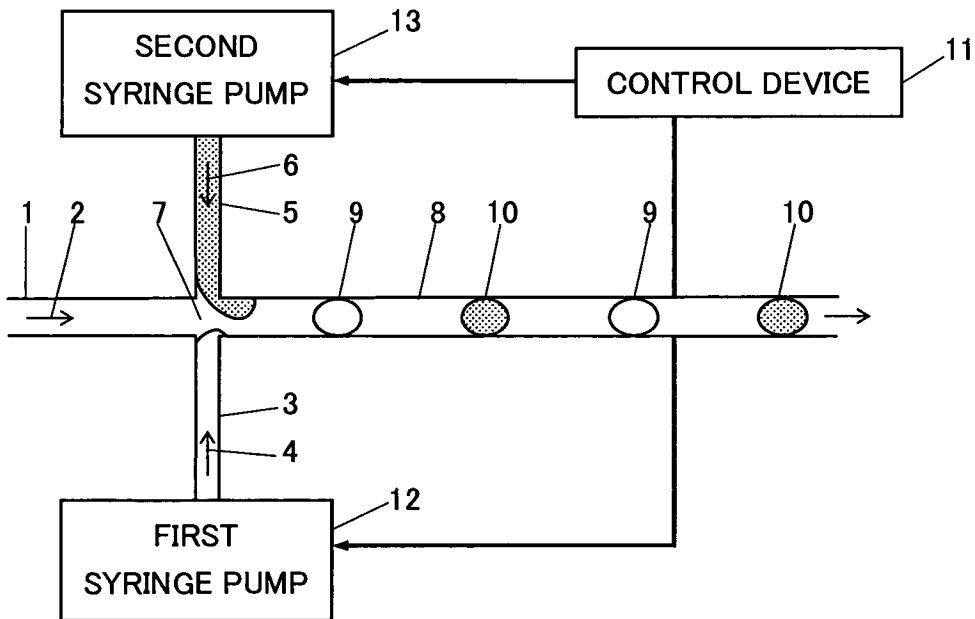

FIG. 2

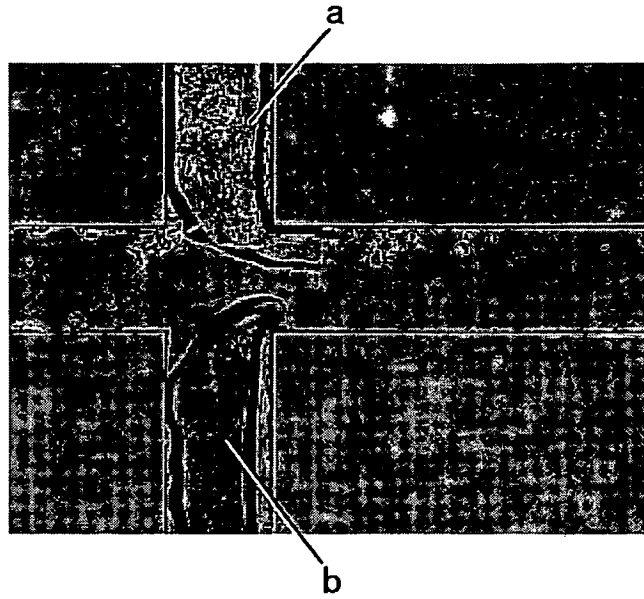

FIG. 3

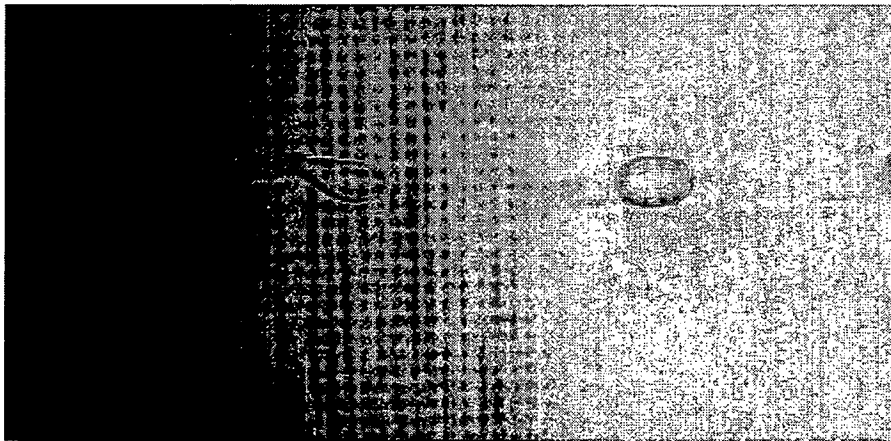

FIG. 4

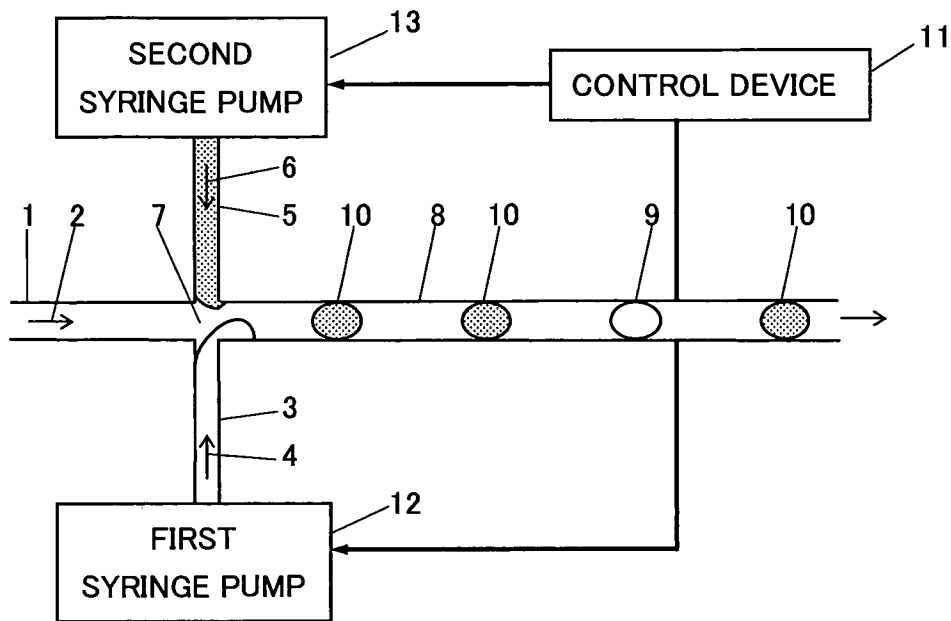

FIG. 5

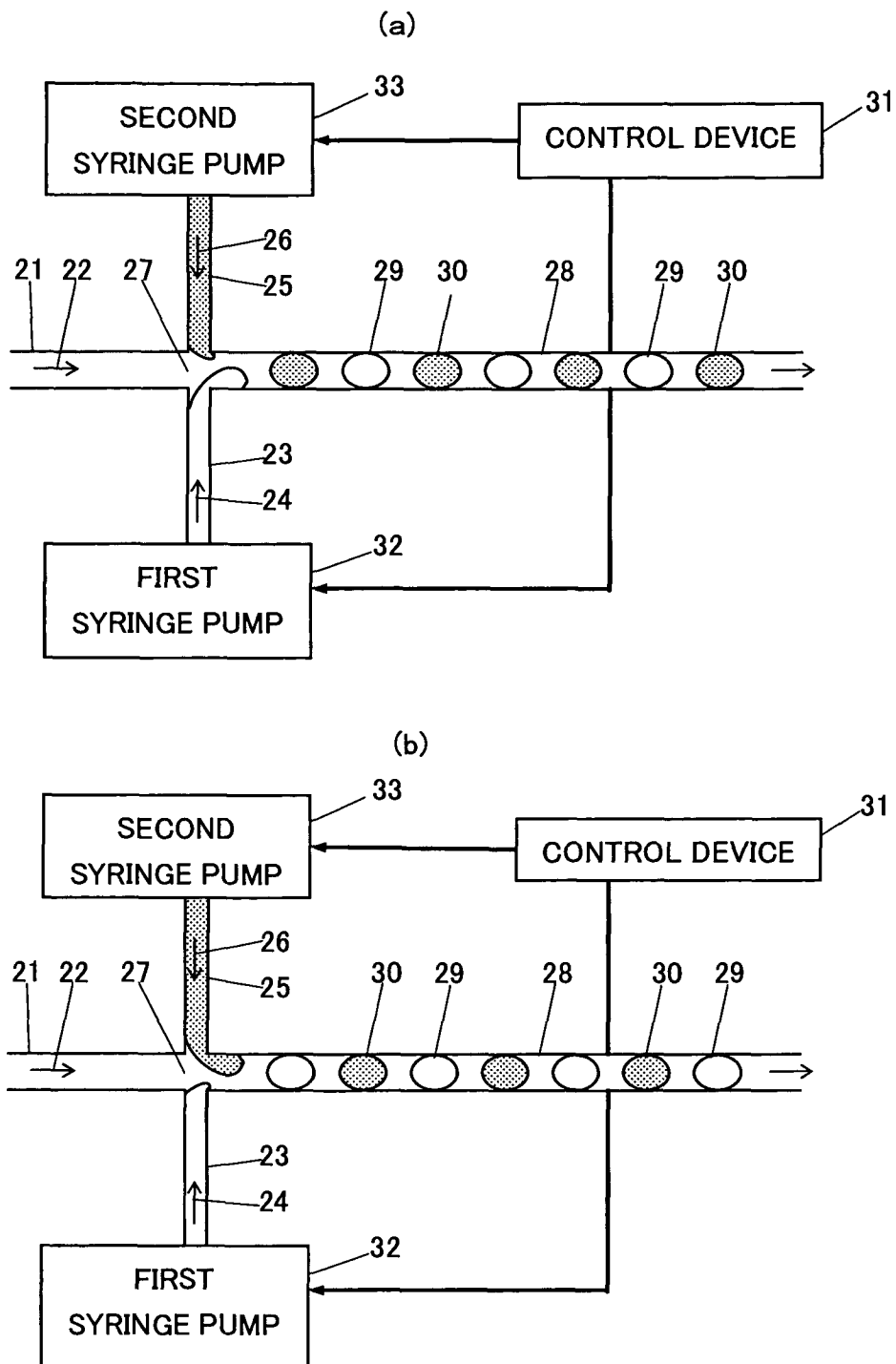

FIG. 6

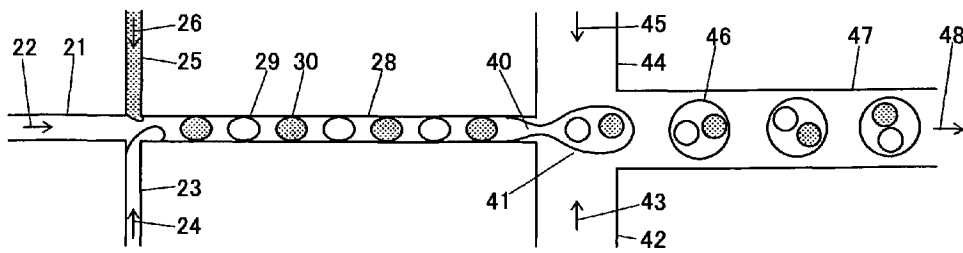

FIG. 7



FIG. 8

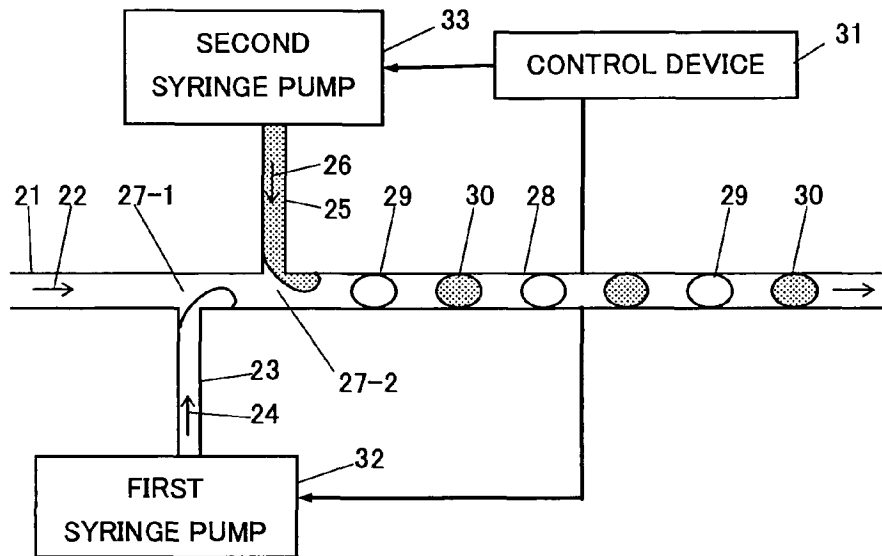

FIG. 9

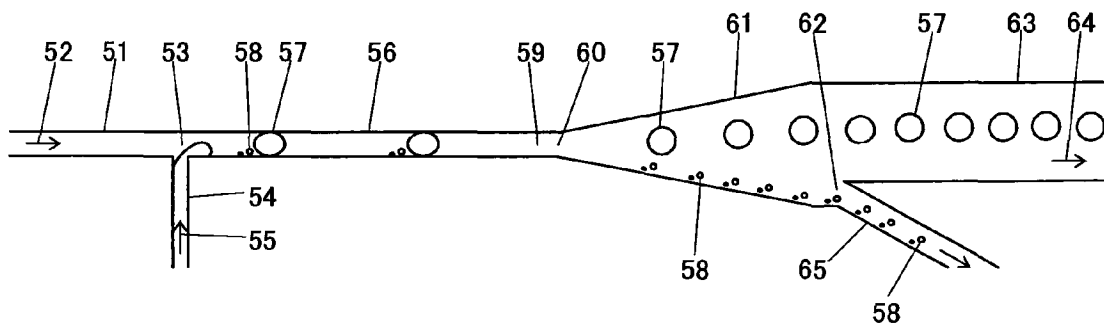

FIG. 10

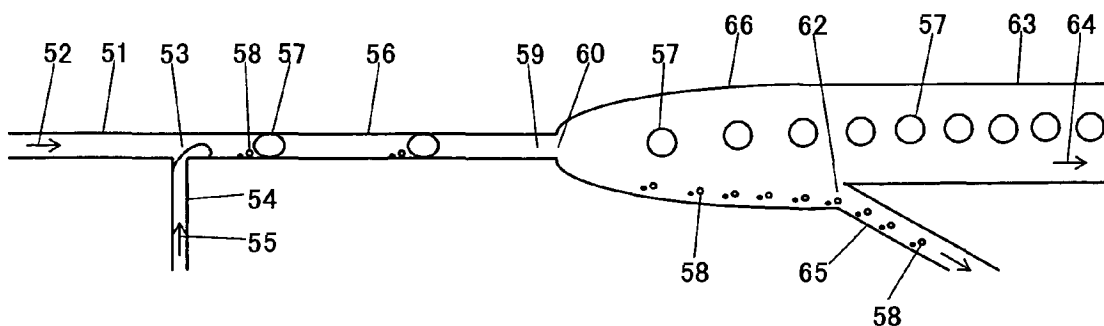

FIG. 11

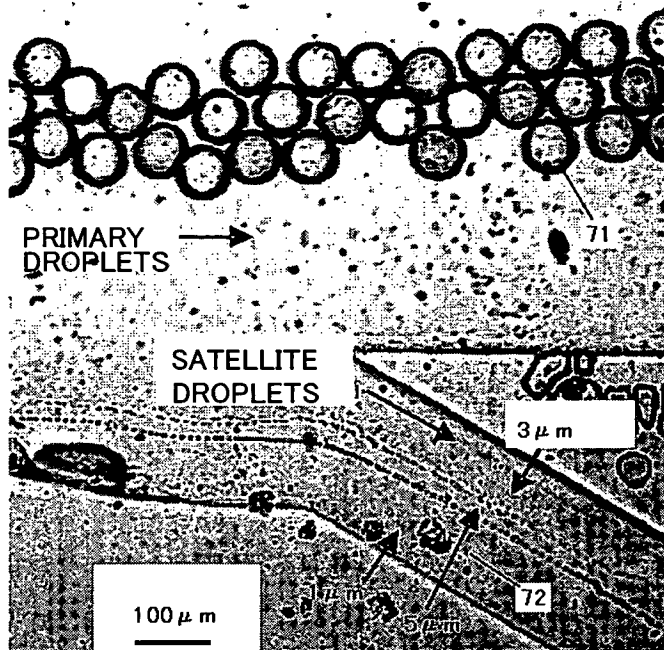

FIG. 12

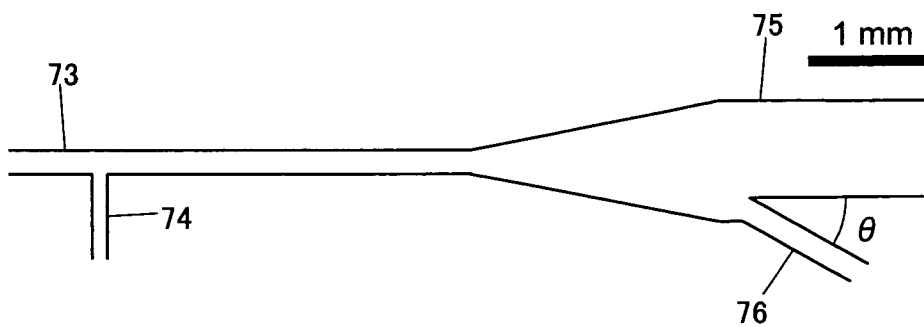



FIG. 13

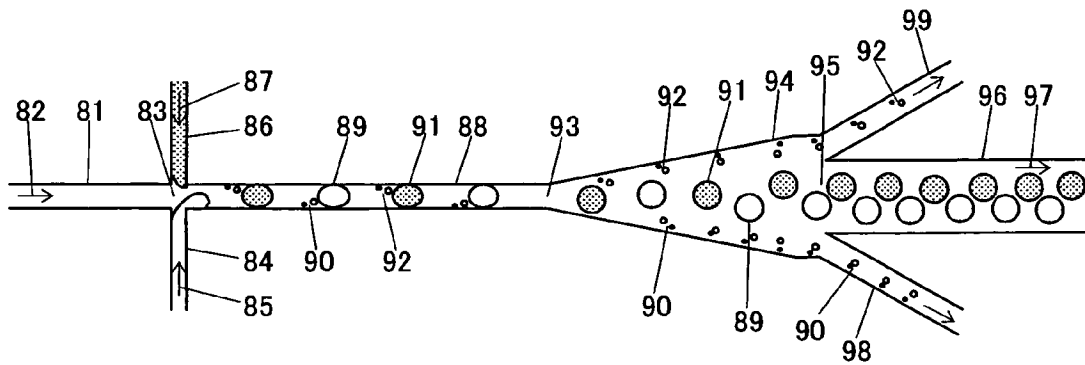
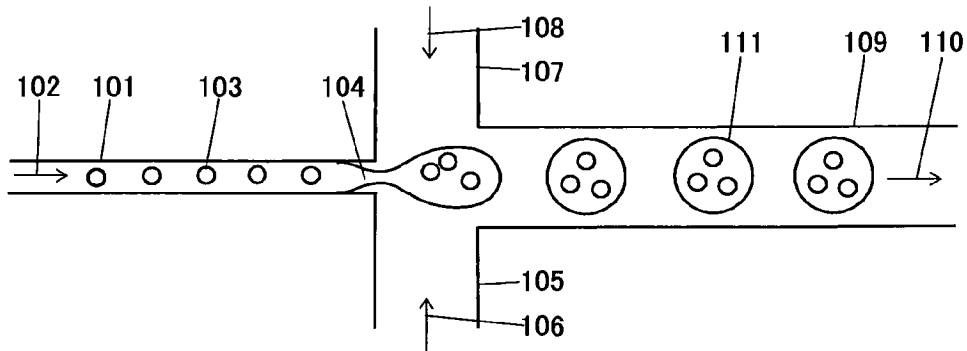

FIG. 14



## METHOD AND DEVICE FOR PRODUCING MICRO-DROPLETS

### TECHNICAL FIELD

The present invention relates to a method and an apparatus for producing microdroplets, and more particularly, relates to a method and an apparatus for producing double emulsion-microcapsules.

### BACKGROUND ART

The inventors of the present invention have already filed a patent application relating to a method for producing emulsions and microcapsules and an apparatus therefor as the following Patent Document 1.  
Patent Document 1: WO 02/068104 A1

### DISCLOSURE OF INVENTION

The above prior art on production of microdroplets was further improved, and an object of the present invention is to provide a method and an apparatus for producing microdroplets with various embodiments.

To these ends, the present invention provides the following.

[1] There is provided a method for producing microdroplets, comprising the step of allowing a first dispersion phase and a second dispersion phase to act on a first continuous phase at an intersection portion among the first continuous phase, the first dispersion phase, and the second dispersion phase, whereby the microdroplets are sequentially produced.

[2] In the method for producing microdroplets according to the above [1], the intersection portion is a cross intersection portion.

[3] In the method for producing microdroplets according to the above [1], the intersection portion includes T-shaped intersection portions, the T-shaped intersection portions being located at positions shifted from each other.

[4] In the method for producing microdroplets according to the above [1], microdroplets formed of the first dispersion phase are different from microdroplets formed of the second dispersion phase.

[5] In the method for producing microdroplets according to the above [2], the first dispersion phase and the second dispersion phase are allowed to alternately act on at predetermined time intervals so that microdroplets having uniform sizes and different components are alternately produced at a regular period.

[6] In the method for producing microdroplets according to the above [3], the first dispersion phase and the second dispersion phase are allowed to alternately act on at predetermined time intervals so that microdroplets having uniform sizes and different components are alternately produced at a regular period.

[7] In the method for producing microdroplets according to the above [5] or [6], the period is changeable.

[8] There is provided a method for producing microdroplets, comprising the steps of: allowing a first dispersion phase and a second dispersion phase to act on a first continuous phase at a cross intersection portion among the first continuous phase, the first dispersion phase, and the second dispersion phase so as to sequentially produce different microdroplets; and supplying a liquid containing the different microdroplets to another cross intersection portion to which the first continuous phase and a second continuous phase are supplied, whereby double emulsion-microcapsules are produced.

[9] There is provided an apparatus for producing microdroplets, comprising: an intersection portion at which a first continuous phase, a first dispersion phase, and a second dispersion phase intersect with each other; a first liquid feed device controlling the first dispersion phase; a second liquid feed device controlling the second dispersion phase; and a control device connected to the first liquid feed device and the second liquid feed device, in which the first liquid feed device and the second liquid feed device are controlled by a signal from the control device so that microdroplets formed of the first dispersion phase and microdroplets formed of the second dispersion phase are sequentially produced.

[10] In the apparatus for producing microdroplets according to the above [9], the intersection portion is a cross intersection portion.

[11] In the apparatus for producing microdroplets according to the above [9], the intersection portion includes T-shaped intersection portions, the T-shaped intersection portions being located at positions shifted from each other.

[12] In the apparatus for producing microdroplets according to the above [10], by the signal from the control device, microdroplets having uniform sizes and different components are alternately produced at a regular period.

[13] In the apparatus for producing microdroplets according to the above [11], by the signal from the control device, microdroplets having uniform sizes and different components are alternately produced at a regular period.

[14] In the apparatus for producing microdroplets according to the above [12] or [13], by the signal from the control device, the period can be changed.

[15] In an apparatus for producing microdroplets according to the above [8], a liquid containing the microdroplets is supplied to another cross intersection portion to which the first continuous phase and the second continuous phase are supplied so as to produce double emulsion-microcapsules.

[16] There is provided a method for producing microdroplets, comprising the steps of: separating a liquid containing primary droplets and satellite droplets into the primary droplets and the satellite droplets at an expansion portion; and recovering the primary droplets and the satellite droplets in a primary droplet recovery channel and a satellite droplet recovery channel, respectively, at a branching portion.

[17] In the method for producing microdroplets according to the above [16], the primary droplets include first and second primary droplets and the satellite droplets include first and second satellite droplets, and at the branching portion, the first and the second primary droplets, the first satellite droplets, and the second satellite droplets are separately recovered.

[18] In the method for producing microdroplets according to the above [16], a liquid containing the satellite droplets is supplied to an intersection portion to which a first continuous phase and a second continuous phase are supplied to produce double emulsion-microcapsules.

[19] There is provided an apparatus for producing microdroplets, comprising: a microdroplet producing portion producing primary droplets and satellite droplets; a microdroplet supply channel supplying microdroplets from the microdroplet producing portion; an expansion portion connected to the microdroplet supply channel; and a branching portion having a satellite droplet recovery channel to recover the satellite droplets and a primary droplet recovery channel connected to a front end of the expansion portion to recover the primary droplets.

[20] There is provided an apparatus for producing microdroplets, comprising: a microdroplet producing portion producing first and second primary droplets and first and second

3

satellite droplets; a microdroplet supply channel supplying microdroplets from the microdroplet producing portion; an expansion portion connected to the microdroplet supply channel; and a branching portion having a primary droplet recovery channel connected to a front end of the expansion portion to recover the first and the second primary droplets, a first satellite droplet recovery channel to recover the first satellite droplets, and a second satellite droplet recovery channel to recover the second satellite droplets.

#### BRIEF DESCRIPTION OF THE DRAWINGS

FIG. 1 includes schematic views each showing the state in which microdroplets are produced at a long period using a cross microchannel when a flow rate ratio between a dispersion phase and a continuous phase is small, according to a first embodiment of the present invention.

FIG. 2 is a view showing the state in which the droplets are alternately produced, as shown in FIG. 1.

FIG. 3 is a photograph taken by a high-speed camera showing the state in which microdroplets having uniform sizes and different components are produced.

FIG. 4 is a view showing the state in which microdroplets are sequentially produced, according to a second embodiment of the present invention.

FIG. 5 includes schematic views of an apparatus showing the state in which microdroplets are produced at a short period using a cross microchannel when a flow rate ratio between a dispersion phase and a continuous phase is large, according to a third embodiment of the present invention.

FIG. 6 is a schematic view showing the state of a fourth embodiment according to the present invention in which double emulsion-microcapsules are produced by using microdroplets which have uniform sizes and have different components and which are alternately produced at a regular period in the third embodiment.

FIG. 7 is a view showing the state of production of a W/O/W type emulsion encapsulating two types of microdroplets, according to the present invention.

FIG. 8 is a schematic view showing a modified embodiment according to the first embodiment of the present invention.

FIG. 9 is a schematic view showing the state of separation of satellite droplets, according to a fifth embodiment of the present invention.

FIG. 10 is a view showing a modified embodiment according to the fifth embodiment shown in FIG. 9.

FIG. 11 is a view showing the state of separation of satellite droplets according to the present invention.

FIG. 12 is a view showing the shape of an acrylic resin-made microchannel shown in FIG. 11.

FIG. 13 is a schematic view showing the state of separation of satellite droplets, according to a sixth embodiment of the present invention.

FIG. 14 is a schematic view showing the state of production of a double emulsion using satellite droplets, according to a seventh embodiment of the present invention.

#### BEST MODE FOR CARRYING OUT THE INVENTION

In a method for producing microdroplets, at a cross intersection portion at which a first continuous phase and a first and a second dispersion phase intersect with each other, different microdroplets are alternately produced by allowing the first dispersion phase and the second dispersion phase to alternately act on the first continuous phase. In addition,

4

various types of microdroplets, in particular, double emulsion-microcapsules can be easily produced in a simple manner.

In addition, primary droplets and satellite droplets are easily separated and then can be recovered separately. In addition, by using the satellite droplets, high-quality and highly precise double emulsion-microcapsules can be manufactured.

#### EMBODIMENTS

Hereinafter, embodiments of the present invention will be described in detail.

FIG. 1 includes schematic views each showing the state in which microdroplets are produced at a long period using a cross microchannel when a flow rate ratio between a dispersion phase and a continuous phase is small, according to a first embodiment of the present invention.

An embodiment will be described in which microdroplets having uniform sizes and different components are alternately produced at a regular period.

In FIG. 1, reference numeral 1 indicates a first microchannel, reference numeral 2 indicates a continuous phase supplied from the first microchannel 1, reference numeral 3 indicates a second microchannel, reference numeral 4 indicates a first dispersion phase supplied from the second microchannel 3, reference numeral 5 indicates a third microchannel, reference numeral 6 indicates a second dispersion phase supplied from the third microchannel 5, reference numeral 7 indicates an intersection portion having a cross structure, reference numeral 8 indicates a fourth microchannel, reference numeral 9 indicates a first microdroplet sent through the fourth microchannel 8, reference numeral 10 indicates a second microdroplet alternately produced with the first microdroplet 9 at a regular period, reference numeral 11 indicates a control device controlling supply of the first dispersion phase 4 and the second dispersion phase 6 in the microchannels, reference numeral 12 indicates a syringe pump (flow rate changeable liquid feed device) which is connected to the control device 11 and which is used as a first liquid feed device supplying the first dispersion phase 4, and reference numeral 13 indicates a syringe pump (flow rate changeable liquid feed device) which is connected to the control device 11 and which is used as a second liquid feed device supplying the second dispersion phase 6.

In this embodiment, using the cross intersection portion 7 of the microchannels, the microdroplets 9 and 10 having uniform sizes are produced at predetermined intervals, so that a line of the microdroplets is formed. That is, when the first syringe pump (flow rate changeable liquid feed device) 12 for the first dispersion phase 4 and the second syringe pump (flow rate changeable liquid feed device) 13 for the second dispersion phase 6 are alternately operated so as to feed the first dispersion phase 4 and the second dispersion phase 6 at the same flow rate, at an appropriate flow rate of the continuous phase 2, the microdroplets 9 and 10 having uniform sizes and different components are alternately produced at the cross intersection portion 7 at a regular period.

FIG. 2 is a view showing the state in which the microdroplets are alternately produced, and FIG. 3 is a photograph taken by a high-speed camera showing the state of production of microdroplets having uniform sizes and different components.

In this embodiment, a glass-made microchannel was used which had a channel width of 80  $\mu\text{m}$  and a depth of 40  $\mu\text{m}$  and which was processed by a hydrophobic treatment. As the dispersion phases shown in FIG. 2, a red ink and a blue ink

5

b each diluted with water were used as the first and the second dispersion phases, respectively, and each dispersion phase was supplied at a flow rate of 0.01 ml/h. A corn oil (viscosity: 58.5 mPa·s, surface tension: 33.2 mN/m (both being measured at 20° C.)) used as the continuous phase was supplied at a flow rate of 0.10 ml/h.

FIG. 4 is a view showing the state in which microdroplets are sequentially produced, according to a second embodiment of the present invention.

In this embodiment, at a cross intersection portion at which a first continuous phase, a first dispersion phase, and a second dispersion phase intersect with each other, the first dispersion phase and the second dispersion phase are allowed to act on the first continuous phase so as to produce different microdroplets, and in this case, by the control using the control device 11, when one droplet 9 is formed from the first dispersion phase, two droplets 10 are then continuously formed from the second dispersion phase.

FIG. 5 includes schematic views of an apparatus showing the state in which microdroplets are produced at a short period using a cross microchannel when a flow rate ratio between a dispersion phase and a continuous phase is large, according to a third embodiment of the present invention.

In this figure, reference numeral 21 indicates a first microchannel, reference numeral 22 indicates a continuous phase supplied from the first microchannel 21, reference numeral 23 indicates a second microchannel, reference numeral 24 indicates a first dispersion phase supplied from the second microchannel 23, reference numeral 25 indicates a third microchannel, reference numeral 26 indicates a second dispersion phase supplied from the third microchannel 25, reference numeral 27 indicates an intersection portion having a cross structure, reference numeral 28 indicates a fourth microchannel, reference numeral 29 indicates a first microdroplet sent through the fourth microchannel 28, reference numeral 30 indicates a second microdroplet alternately produced with the first microdroplet 29 at a regular period, reference numeral 31 indicates a control device controlling supply of the first dispersion phase 24 and the second dispersion phase 26 in the microchannels, reference numeral 32 indicates a first syringe pump (flow rate changeable liquid feed device) which is connected to the control device 31 and which is used as a first liquid feed device supplying the first dispersion phase 24, and reference numeral 33 indicates a second syringe pump (flow rate changeable liquid feed device) which is connected to the control device 31 and which is used as a second liquid feed device supplying the second dispersion phase 26.

In this third embodiment, the microdroplets 29 and 30 are produced at a shorter period compared to the case in which the microdroplets 9 and 10 are alternately produced in the first embodiment shown in FIG. 1.

FIG. 6 is a schematic view showing the state of a fourth embodiment according to the present invention in which double emulsion-microcapsules are produced by using microdroplets which have uniform sizes and have different components and which are alternately produced at a regular period in the third embodiment.

In this embodiment, reference numeral 40 indicates an outlet for ejecting two types of microdroplets, that is, the microdroplets 29 and 30 which are alternately produced at a regular period and which have uniform sizes and different components, reference numeral 41 indicates an intersection portion having a cross structure, reference numeral 42 indicates a fifth microchannel, reference numeral 43 indicates a continuous phase supplied from the fifth microchannel 42, reference numeral 44 indicates a sixth microchannel, reference numeral 45 indicates a continuous phase supplied from

6

the sixth microchannel 44, reference numeral 46 indicates a produced microcapsule (double emulsion), reference numeral 47 indicates a microcapsule (double emulsion) recovery channel recovering the microcapsules (double emulsion) 46, and reference numeral 48 indicates a continuous phase sending the microcapsule (double emulsion) 46.

As described above, the microdroplets 29 and 30 alternately produced at a regular period and having different components are further encapsulated, so that the microcapsules (double emulsion) 46 containing the same numbers of two types of microdroplets are obtained.

FIG. 7 is a view showing the state of production of a W/O/W type emulsion encapsulating two types of microdroplets, according to the present invention.

Next, as for a method for producing microdroplets using microchannels, a method for obtaining a monodispersion emulsion will be described in which satellite droplets are separated and removed from microdroplets produced in the microchannels.

FIG. 8 is a schematic view showing a modified embodiment according to the first embodiment of the present invention;

In this embodiment, the structure is formed in which different droplets are ejected from a T-shaped intersection portion 27-1 and a T-shaped intersection portion 27-2 which is located at a position shifted therefrom, and the first microdroplets 29 sent through the fourth microchannel 28 and the second microdroplets 30 alternately produced with the first microdroplets 29 at a regular period are sequentially produced. The rest of the structure is equivalent to that in the first embodiment.

FIG. 9 is a schematic view showing the state of separation of satellite droplets, according to a fifth embodiment of the present invention.

In this figure, reference numeral 51 indicates a first microchannel (continuous phase supply channel), reference numeral 52 indicates a continuous phase supplied from the first microchannel (continuous phase supply channel) 51, reference numeral 53 indicates an intersection portion having a T-shaped structure, reference numeral 54 indicates a second microchannel (dispersion phase supply channel), reference numeral 55 indicates a dispersion phase supplied from the second microchannel (dispersion phase supply channel) 54, reference numeral 56 indicates a third microchannel, reference numeral 57 indicates a primary droplet produced at the intersection portion 53 having a T-shaped structure and sent through the third microchannel 56, reference numeral 58 indicates a satellite droplet produced together with the primary droplet 57, reference numeral 59 indicates an outlet of the third microchannel 56, reference numeral 60 indicates a junction portion of a microchannel connected to the outlet 59, reference numeral 61 indicates an expansion portion (tapered portion) of the microchannel, reference numeral 62 indicates a branching portion, reference numeral 63 indicates a primary droplet recovery channel recovering the primary droplets 57, reference numeral 64 indicates a liquid carrying the primary droplets, and reference numeral 65 indicates a satellite droplet recovery channel recovering the satellite droplets 58.

As shown in FIG. 9, when the primary droplets 57 are produced at the intersection portion 53 having a T-shaped structure, the fine satellite droplets 58 are simultaneously produced. In the case in which microcapsules (double emulsion) are produced using the primary droplets 57, it is often unfavorable if the satellite droplets 58 are encapsulated in the microcapsules (double emulsion) together with the primary droplets 57.

Accordingly, in order to avoid the case described above, at the expansion portion **61**, the primary droplets **57** are designed to be sent to the right side in the same manner as that before, and the satellite droplets **58** are designed to be sent downward, that is, the primary droplets **57** are sent toward the primary droplet recovery channel **63**, and the satellite droplets **58** are sent downward to the satellite droplet recovery channel **65** recovering the satellite droplets **58**.

According to this embodiment, the expansion portion (tapered portion) **61** and the branching microchannels **63** and **65** are provided downstream of the microdroplet production portion (intersection portion having a T-shaped structure) **53**, and the satellite droplets **58** can be continuously separated from the primary droplets **57** thus formed.

Instead of the expansion portion **61** having a taper described above, an expansion portion **66** having a curved surface may be used, as shown in FIG. **10**.

FIG. **11** is a view showing the state of separation of satellite droplets according to the present invention.

As shown in this figure, primary droplets (diameter: 70  $\mu\text{m}$ ) **71** are separated from satellite droplets **72** (diameters: 1, 3, and 5  $\mu\text{m}$ ).

FIG. **12** is a view showing the shape of an acrylic resin-made microchannel shown in FIG. **11**, this microchannel is formed of a first microchannel (continuous phase supply channel) **73** of 200  $\mu\text{m}$  wide and 100  $\mu\text{m}$  deep, a second microchannel (dispersion phase supply channel) **74** of 120  $\mu\text{m}$  wide and 100  $\mu\text{m}$  deep, a primary droplet recovery channel **75** of 800  $\mu\text{m}$  wide and 100  $\mu\text{m}$  deep, and a satellite droplet recovery channel **76** of 200  $\mu\text{m}$  wide and 100  $\mu\text{m}$  deep, and in addition, the branching angle  $\theta$  of the satellite droplet recovery channel **76** to the primary droplet recovery channel **75** is 30°.

In this embodiment, as the dispersion phase and the continuous phase, pure water and a corn oil (viscosity: 58.5 mPa·s, surface tension: 33.2 mN/m, both being measured at 20° C.) were used, respectively, and the flow rate control was performed for each phase by a liquid feed device (syringe pump).

As for the flow rate conditions in FIG. **11**, the dispersion phase flow rate and the continuous phase flow rate were set to 1.0 ml/h and 15.0 ml/h, respectively, and it was confirmed that the primary droplets **71** (diameter: approximately 70  $\mu\text{m}$ ) were separated from the satellite droplets **72** having three different sizes (diameters: 1, 3, and 5  $\mu\text{m}$ ). It was observed that the satellite droplets having different sizes form respective lines and flow into the branching channel. When the flow rate of the dispersion phase and that of the continuous phase are increased, the size of the satellite droplets and the production number thereof both tend to be increased.

FIG. **13** is a schematic view showing the state of separation of satellite droplets, according to a sixth embodiment of the present invention.

In this figure, reference numeral **81** indicates a first microchannel (continuous phase supply channel), reference numeral **82** indicates a continuous phase supplied from the first microchannel (continuous phase supply channel), reference numeral **83** indicates an intersection portion having a cross structure, reference numeral **84** indicates a second microchannel (first dispersion phase supply channel), reference numeral **85** indicates a first dispersion phase supplied from the second microchannel (first dispersion phase supply channel) **84**, reference numeral **86** indicates a third microchannel (second dispersion phase supply channel), reference numeral **87** indicates a second dispersion phase supplied from the third microchannel (second dispersion phase supply channel) **86**, reference numeral **88** indicates a fourth microchan-

nel, reference numeral **89** indicates a first primary droplet produced at the intersection portion **83** having a cross structure, reference numeral **90** indicates a first satellite droplet produced simultaneously with the first primary droplet **89**, reference numeral **91** indicates a second primary droplet produced at the intersection portion **83** having a cross structure, reference numeral **92** indicates a second satellite droplet produced simultaneously with the second primary droplet **91**, reference numeral **93** indicates a junction portion of a microchannel connected to an outlet ejecting the droplets **89** to **92**, reference numeral **94** indicates an expansion portion (tapered portion) of the microchannel, reference numeral **95** indicates a branching portion, reference numeral **96** indicates a primary droplet recovery channel recovering the primary droplets **89** and **91**, reference numeral **97** indicates a liquid carrying the primary droplets **89** and **91**, reference numeral **98** indicates a first satellite droplet recovery channel recovering the first satellite droplets **90**, and reference numeral **99** indicates a second satellite droplet recovery channel recovering the second satellite droplets **92**.

In this embodiment, the expansion portion (tapered portion) **94** and the first and the second satellite droplet recovery channels **98** and **99** are provided downstream of the microdroplet production portion (intersection portion having a cross structure) **83**, and the first and the second satellite droplets **90** and **92** can be independently separated from the primary droplets **89** and **91**.

According to the structure described above, the droplet production and the classification operation can be simultaneously performed in the microchannels, and monodispersion droplets/fine particles can be advantageously obtained without classification operation performed outside the apparatus.

The satellite droplets thus separated and recovered are very fine, and hence these droplets can be used for production of a double emulsion.

FIG. **14** is a schematic view showing the state of production of a double emulsion using satellite droplets, according to a seventh embodiment of the present invention.

In this figure, reference numeral **101** indicates a first microchannel (satellite droplet supply channel), reference numeral **102** indicates a liquid carrying satellite droplets, reference numeral **103** indicates a satellite droplet, reference numeral **104** indicates an outlet for the satellite droplets, reference numeral **105** indicates a second microchannel (continuous phase supply channel), reference numeral **106** indicates a first continuous phase supplied from the second microchannel (continuous phase supply channel) **105**, reference numeral **107** indicates a third microchannel (continuous phase supply channel), reference numeral **108** indicates a second continuous phase supplied from the third microchannel (continuous phase supply channel) **107**, reference numeral **109** indicates a recovery channel for a double emulsion using satellite droplets, reference numeral **110** indicates a liquid carrying the double emulsion using satellite droplets, and reference numeral **111** indicates the double emulsion using satellite droplets.

According to this embodiment, as shown in FIG. **14**, the double emulsion **111** encapsulating the satellite droplets **103** can be produced.

Incidentally, the present invention is not limited to the above examples, and various modifications may be carried out without departing from the spirit and the scope of the present invention and may not be excluded therefrom.

According to the present invention, using intersecting microchannels in combination, various types of microdrop-

lets, in particular, double emulsion-microcapsules can be easily produced in a simple manner.

In addition, the primary droplets and the satellite droplets can be easily separated and recovered separately. Accordingly, high-quality and highly precise double emulsion-microcapsules can be manufactured.

#### INDUSTRIAL APPLICABILITY

The method for producing microdroplets and the apparatus therefor, according to the present invention, can be used as a tool producing microcapsules in the fields of gene and pharmaceutical technologies.

The invention claimed is:

1. An apparatus for producing microdroplets, comprising:
  - a microdroplet producing portion including:
    - a cross intersection portion at which a first continuous phase supplied from a continuous phase supply channel, a first dispersion phase supplied from a first dispersion phase supply channel, and a second dispersion phase supplied from a second dispersion phase supply channel intersect with each other;
    - a first liquid feed device controlling the first dispersion phase;
    - a second liquid feed device controlling the second dispersion phase; and
    - a control device connected to the first liquid feed device and the second liquid feed device, wherein the first liquid feed device and the second liquid feed device are controlled by a signal from the control device so

that first primary microdroplets and first fine satellite droplets formed of the first dispersion phase and second primary microdroplets and second fine satellite droplets formed of the second dispersion phase are sequentially produced;

- a microdroplet supply channel supplying the first primary microdroplets and the second primary microdroplets and the first fine satellite droplets and the second fine satellite droplets from the microdroplet producing portion;
  - an expansion portion connected to the microdroplet supply channel; and
  - a branching portion having a primary droplet recovery channel connected to a front end of the expansion portion to recover the first primary microdroplets and the second primary microdroplets, a first fine satellite droplet recovery channel positioned on one side of the primary droplet recovery channel to recover the first fine satellite droplets, and a second fine satellite droplet recovery channel positioned on the other side of the primary droplet recovery channel to recover the second fine satellite droplets.
2. The apparatus for producing microdroplets, according to claim 1, wherein by the signal from the control device, microdroplets having uniform sizes and different components are alternately produced at a regular period.
  3. The apparatus for producing microdroplets, according to claim 2, wherein by the signal from the control device, the period is changeable.

\* \* \* \* \*